

## USING COMBINES FOR CLEANING GRAIN CROPS BY NON-TRADITIONAL TECHNOLOGIES

/

## ИСПОЛЬЗОВАНИЕ КОМБАЙНОВ НА УБОРКЕ ЗЕРНОВЫХ КУЛЬТУР ПО НЕ ТРАДИЦИОННЫМ ТЕХНОЛОГИЯМ

Buryanov Alexey, Chervyakov Ivan <sup>1</sup>

Federal State Budgetary Scientific Institution «Agricultural Research Centre «Donskoy» / Russia

Tel: +79515253806; E-mail: bern7771@rambler.ru

DOI: <http://doi.org/10.35633/INMATEH-59-03>

**Keywords:** combine harvester, stripper header, construction, grain, loss

### ABSTRACT

*The application of grain harvesting technology, using the method of stripping plants at the root, allows increasing combines' productivity and efficiency 1.4-2.0 times. As a result of tests which were held both in the fields and in a certain created laboratory setup, it was determined that the share of the heap, entering the straw walkers, will be increased 2.5 times if a gap between the longitudinal ribs of the deck is changed from 11.0 to 9.0 mm while shattering of grain level is preserved as acceptable.*

### РЕЗЮМЕ

*Применение технологии уборки зерновых культур методом очеса растений на корню позволяет увеличить производительность комбайнов и их эффективность в 1.4-2.0 раза. По результатам исследований, выполненных в полевых условиях и на специально созданной лабораторной установке установлено, что при изменении зазора между продольными ребрами деки с 11.0 до 9.0 мм доля вороха, поступающего на соломотряс, увеличивается в 2.5 раза при сохранении уровня дробления зерна на допустимом уровне.*

### INTRODUCTION

Grain harvesting is one of the energies and resource-intensive work performed in the production of agricultural products. At present, combines are the main tools for harvesting grain and other crops and in the near future they will be the main tools as well. The harvesters' park of the country numbers 150 000 combine harvesters while the required number is 300 000. Due to low availability, the load on one combine is up to 425 hectares (SHamin A.E. *et al*, 2018). Most of the harvesters which are used in the south of the country are single-drum combines of the "Don" and "Acros" families produced by "Rostselmash". Tending to reduce harvesting time, agricultural enterprises operate with the latest modifications combines with powerful engines in modes which are 1.5-2.0 times higher than recommended; it leads to great increase of grain loses, grain injury and crushing. The correctness of this conclusion is confirmed by the results of the research works given in (Lizhang X. and Yaoming L., 2011; Patel S.R. and Varshney B.P., 2016). To solve the problem, science proposes a number of fundamentally new technical and technological solutions based on some new principles of influence on the inflorescence of the harvested crop the implementation of which will considerably improve the quality of the threshing process and the performance of the harvesting machines along with an increasing of the combine park. These are, for example, such new principles as threshing by using compressed air jets or by pneumatic impacts or using ultrasonic vibrations. (Moskovskij M.N., Kovaleva A.V., Kuren S.G., 2017; Moskovskij M.N. *et al*, 2015).

The ideas listed above are the most interesting among all variety of proposed solutions but it is necessary to conduct basic research works that require relevant research teams and capital investments before applying them in the technical devices, machines.

In prospect, the best way should be considered the use of unconventional technologies for harvesting grain and other crops by stripping plants at the roots, particularly with a stripping combine, and adaptation of stripping devices to zone conditions.

<sup>1</sup> Alexey Buryanov – d. tech. sc., professor, main research officer; Ivan Chervyakov – junior research officer

This tendency is developed both in Russia and in the USA, Great Britain and Canada. The feeding of the stripping heap containing the minimum amount of straw mass into the threshing unit of the combine allowed increasing its productivity and efficiency 1.4-2.0 times (Berenshtein I.B. and Shabanov N.P., 2017; Izmajlov A.YU. and SHogenov YU.H., 2017). However, this method is a new one and, naturally, needs to be improved. The research investigations carried out for some years at the State Scientific Institution “NSRIMEA”, now FSBSI «ARC “Donskoy”», aimed at further developing the process of stripping grain crops with a single-drum header, the mathematical model of the process was worked out, laboratory facilities were created for testing the results obtained on theoretical models (Buryanov M.A., 2011), and the production of «Ozone» stripping reapers was started according to the documents developed at our institute (the manufacturer of OJSC “Penzmash” and “Yuzhanka” produced “NSRIMEA” + “AGROTRADE”). This process is studied by a lot of authors in different countries, such as China (Yuan J., Lan Y., 2007), India (Bhanage G.B., Shahare P.U. et al, 2017), Iran (Chegini G.R., 2013; Chegini G.R., Mirnezami S.V., 2012), Great Britain (Shelbourne Reynolds Engineering Ltd) and others.

Study and tests of combines with stripping headers in field works showed that the stripped heap goes almost entirely to the sieve after passing through the deck, where the gaps between the ribs were rated at a bigger quantity of straw content. In this case, the straw walker is underloaded. The entering stripped mass differs significantly in its fractional composition from the mass in traditional harvesting. The share of grain in the stripping heap varies from 75% to 85%. Therefore, the threshing and separating device of modern combine harvesters, especially single-drum ones, is to work with an unconventional heap, having technological settings for its other fractional composition. It was hypothesized that it was possible to choose such gap between longitudinal ribs of the concave in which a large part of the fractions containing larger particles of the heap would flow to the straw walker, thereby reducing the amount of material entering the sieve.

The probability of the grain crushing growth appears if the gap is decreased below maximal linear dimensions of harvested grain.

In accordance with those mentioned above, the purpose of the research was to determine the influence of the deck gap on the distribution of thrashing mass between cleaning and straw walker, keeping the degree of grain crushing limited with GOST. This research was carried on the threshing of winter wheat stripped heap in a threshing unit with one drum.

## MATERIALS AND METHODS

Experimental studies were carried out in a laboratory setup, the scheme of which is shown in figure 1. The flow of the stripping heap into the device 5 was carried out using the feed conveyor 1 (fig.1).

Stripped heap portion was prepared for the experiments. The stripping harvester “Yuzhanka-6”, produced by “NSRIMEA” + “Agrotraid”, was used. The harvester coverage was 6.0m. The harvested crop was soft winter wheat “Luchezar” with crop capacity 6.96t/ha and with weak link between grain and ear (Buryanov A.I., Chervyakov I.V. et al., 2018); the gluten content in a grain was 20.8%, protein content – 12.2%; the mass of 1000 seeds was 42.6g, grain moisture – 11-12%. There was the following fractional composition: free grain - 65%; un-threshed ears and their parts with grain – 20%; stems, chaff – 15%.

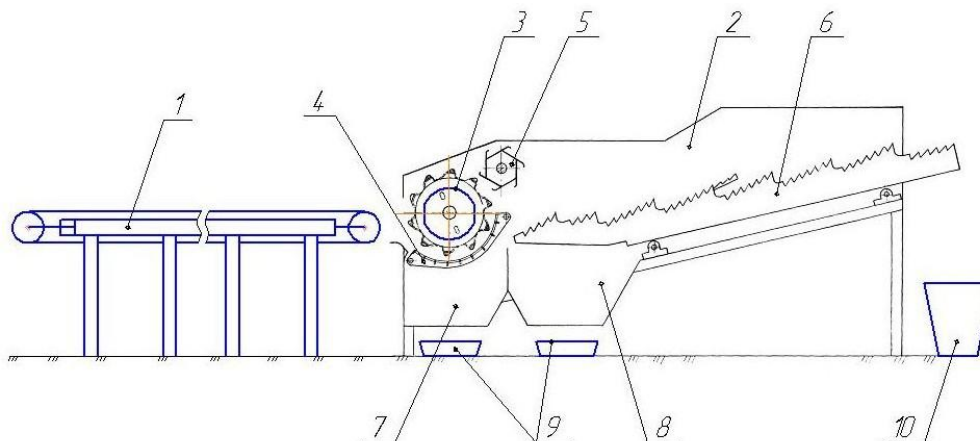

**Fig. 1 – Diagram of the laboratory setup**

1 – feed conveyor; 2 – replaceable deck; 3 – drum; 4 – beater; 5 – threshing and separating device; 6 – straw walker; 7 – basket; 8, 10 – funnel; 9 – pallet

The overall dimensions of the laboratory unit and its working parts are taken on the basis of the size of a straw walker key 6 equal 0.3 m (fig. 1).

The working bodies were driven by an electric motor, separately for the threshing-separating device 5 and for the conveyor 1 (fig. 1) by means of chain and V-belt transmissions.

The cylinder-concave gaps 3 and the bars of the deck 2 (fig.1) were pre-installed: at the entrance – 20.0 mm, at the exit – 5.0 mm.

Working out the plan of the experiment, we used the data obtained after the threshing of winter wheat by a combine “Acros”, stripping header “Yuzhanka-6” and header of continuous cutting. It was found that the peripheral speed of the rasp-bar cylinder with a diameter of 0.8 m, which was traditionally recommended for threshing the heap, was exceeded at threshing stripped heap and caused an increase of grain crushing. By reducing peripheral speed to 750 rpm (31.4 m/s) on a combine “Acros”, equipped with stripping header, we achieved the level of grain threshing analogous to the level of grain threshing of combine that was equipped with a direct-flow header of continuous cutting, having peripheral speed of the cylinder 800 rpm (33.5 m/s).

Taking into account the results of field work, we carried on prospecting work by using a part of serial deck that had a gap between ribs of 11.0 mm and changing the peripheral speed of drum (cylinder) in the range 600-800 rpm, which corresponded to a speed of bars of 25.1 – 33.5 m/s.

We observed short threshing to 3% at peripheral speed of a drum of 600 rpm (25.1 m/s), so if a combine is equipped with a finish-threshing device, it leads to circulation of grain for the rethreshing. As there wasn't a finish-threshing device on the laboratory setup, it was impossible to take into account its contribution to grain crushing process. It was noted more than 2.0% rising of grain crushing at the speed of 800 rpm (33.5 m/s) while the threshing grade wasn't changed. The following levels of peripheral speed were considered: upper value 31.4 m/s, middle value 29.3 m/s and minimal value 27.2 m/s.

As the gap of standard deck is 11.0 mm, it was taken as upper value; minimal level was 7.0 mm that was less than maximal linear size of “Luchezar” corn seed (which is 8.6 mm); middle value was 9.0 mm. The sequence and conditions of experimentations were made according to the experiment plan (table 1); it was got in the program “Statistica” (13 version). The experiments were carried out triply; then, the mid value was determined.

Table 1

**Matrix of experiment planning for the intensification of the stripping heap threshing process and its separation in the laboratory setup**

Number of experiments	Factors and their magnitudes	
	Peripheral speed of a threshing drum rotation [m/s]	Gaps between deck bars [mm]
1	29.3	11.0
2	27.2	11.0
3	27.2	9.0
4	27.2	7.0
5	29.3	9.0
6	31.4	11.0
7	29.3	7.0
8	31.4	9.0
9	31.4	7.0

The rest of parameters were fixed at the next level:

- amount of stripped heap was 1.6 kg/s, which corresponds to the flow of 8.0 kg/s during the operation of the threshing device with a width of 1.5 m installed for commercially available combines;
- moisture content was in the range of 11.0-12.0%;
- fractional composition of the heap supplied to the installation was constant: free grain – 65%, un-threshed ears and their parts with grain – 20%, plant stalks, chaff – 15%.

## RESULTS

A replaceable deck 0.3 m wide was installed just before the test. Figure 2a shows the feed conveyor with a heap on it before the experiment.

During the experiments, a high-speed shooting of the threshing process was carried out with the Sony Mark 4 camera over the planned experiments. One frame of the shooting is shown in figure 2b.

High-speed shooting made it possible to have a good look at the threshing process during the passage of the stripped heap in the threshing device. When the unit worked with a deck having 9.0 mm gap between bars and the peripheral speed of 31.4 m, grain crushing achieved 1.91%, which is almost equal to the damage level with serial deck -1.90%. It was determined that when the gap was decreased to 7.0 mm grain crushing increased to 2.35%.



Fig. 2 – a) laboratory feed conveyor with stripped heap of winter wheat;  
b) high-speed shooting frame of the threshing process

Table 2 shows the planned experimental data, values of heap separation, values of grain crushing obtained at the laboratory setup.

Table 2

The results of the experiments

Experiment number	Factors		Dependent variable	
	The gap between the ribs of the deck [mm]	Peripheral speed of drum [m/s]	Heap separation degree [%]	Grain crushing [%]
1	11,0	29.3	15.5	1.62
2	11.0	27.2	17.0	1.38
3	9.0	27.2	30.0	1.39
4	7.0	27.2	35.0	1.9
5	9.0	29.3	33.0	1.66
6	11.0	31.4	13.0	1.9
7	7.0	29.3	35.5	2.17
8	9.0	31.4	26.0	1.91
9	7.0	31.4	28.0	2.35

Maximal value of heap separation level is 35.5% if a gap is 7.0 mm and peripheral speed is 29.3 m/s, but grain crushing is 2.17%, which is over the value regulated by GOST. If peripheral speed of a drum is increased to 31.4 m/s, heap separation degree is decreased to 28.0% and grain crushing grows to 2.35%. Heap separation decreases while speed grows because of grating increasing of non-grain part of the harvest and because of its passing through the deck.

If the grain crushing level is less 2.0% (according to GOST), heap separation maximal degree is 33.0% when the gap is 9.0 mm and peripheral speed is 29.3 m/s.

When the speed is 27.2 m/s, heap separation degree is practically the same, it equals 30.0% but grain crushing level decreases to 1.39%.

Figure 3 shows the three dimensional surfaces of gap and peripheral speed dependences of the heap separation and crushing level ("Statistica", ver.13).



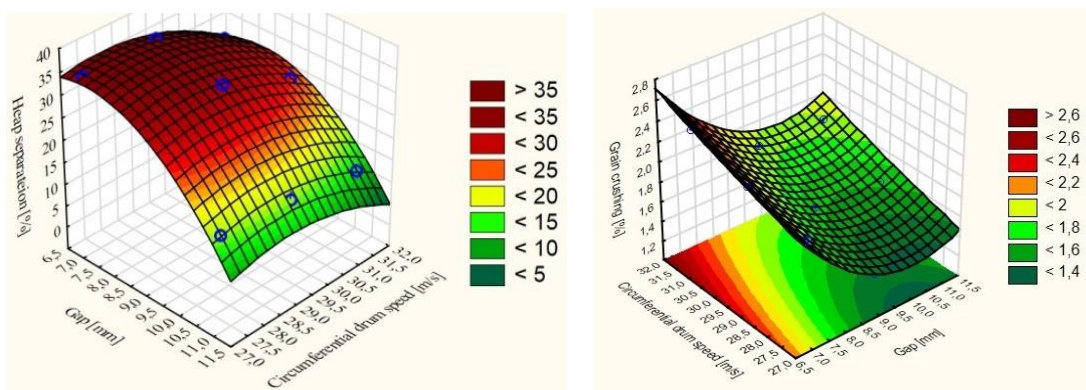

Fig. 3 – Responses surfaces of heap separation and grain crushing to alternative drum operating speed and gap between the deck's ribs dependencies

Experimental data were processed by means of program package “Statistica” (ver.13) and the response surface equations were obtained as uncoded ones:

$$Z = -577.7036 + 15.8512 \times X + 39.2810 \times Y - 1.4167 \times X^2 + 0.1786 \times X \times Y - 0.7181 \times Y^2 \quad (1)$$

where:

X – a gap between deck ribs (mm); Y – drum peripheral speed (m/s); Z – heap separation level (%). Coefficient of determination is  $R^2 = 0.98$ .

As grain crushing degree was determined in the experiment, change rating was defined as the following equation:

$$W = 11.6058 - 1.7111 \times X - 0.2170 \times Y + 0.0650 \times X^2 + 0.0137 \times X \times Y + 0.0034 \times Y^2 \quad (2)$$

where:

X – the gap between deck ribs (mm); Y – drum peripheral speed (m/s); W – grain crushing degree (%). Coefficient of determination is  $R^2 = 0.99$ .

Both equations show good convergence with real values. High determination coefficients 0.98 and 0.99 show that changing of factors, gap and peripheral speed describe about 99% of dependent variables changes.

It should be noticed that all these data are true for the winter wheat “Lucheazar”, grown in the south Russia concrete climate conditions; this kind of wheat has weak link between grain and ear. Similar kinds of grain are grown at the half area used for winter wheat in the region. That is why these results may be used for choosing the expendable deck parameters for the combines used for harvesting winter wheat, having similar physical and mechanical features. The researches show that the change of grain kind and conditions of growing (Khusanov I., Babaev S. at al, 2011) leads to varying physical and mechanical characteristics such as grain size, its strength even in one field limits. But this technology is used for harvesting winter wheat rigid varieties, barley, rye, cereal sorghum, linen and other crops whose physical and mechanical characteristics are significantly different. That is why the adaptation researches of deck parameters to variety of crops properties and designing of its technological model are high-priority tasks now and for the near future.

## CONCLUSIONS

When threshing winter wheat “Lucheazar” stripped heap in a single drum threshing device, furnished with a deck where the gap between ribs is decreased from 11.0 to 9.0 mm, the level of heap separation between cleaning and straw walker increased from 15.5 to 33.0% and it allowed to reduce the air and sieve cleaning load.

It may be suggested that these results are true for all other kinds of wheat with similar physical and mechanical features. The results are very important as winter wheat share is about 50% of the cultivated area of the country. So, one of the ways of winter wheat harvesting by combines with a single drum threshing devices can be the usage of expendable deck with the gap of 9.0 mm between ribs. It is necessary to carry out analogous researches to determine the gap range for other crops threshing.

In perspective, combine threshing devices should have mechanisms for timely changing of the gap between deck's ribs for maintaining optimal regimes with heaps having different fractional composition and for harvesting technology changing.

## REFERENCES

- [1] Berenshtein I.B., Shabanov N.P., (2017), Resource-saving technologies of cereals cleaning (bicycle) cultures (Ресурсосберегающие технологии уборки зерновых (колосовых) культур), *V.I. Vernadsky Crimean Federal University (Федеральное государственное автономное образовательное учреждение высшего образования Крымский федеральный университет им. В.И. Вернадского)*, Issue 10(173), pp. 62-73, Simferopol/Russia;
- [2] Buryanov A.I., Chervyakov I.V., Kolinko A.A., Pakhomov V.I., Ionova E.V., Khlystunov V.F., (2018), Methods and results of determining the natural force of the connection of grain with an ear during the period of ripening and full ripeness (Методы и результаты определения естественной силы связи зерна с колосом в период созревания и полной спелости), *Grain economy of Russia (Зерновое хозяйство России)*, Issue 6(60), pp. 21-25, Zernograd/Russia (DOI 10.31367/2079-8725-2018-60-6-21-25);
- [3] Buryanov A.I., Buryanov M.A., Dmitrenko A.I., Kolesnikov G.E., Chervyakov I.V., (2014), *Laboratory setup for the study of the parameters and modes for grain crops stripping process*, Patent, No.136743, Russia;
- [4] Buryanov M.A., (2011), *Parameters and modes of the process of grain crops processing on the harvester header (Параметры и режимы процесса очеса зерновых культур навесной на комбайн жаткой)*, PhD dissertation, Azov-Black Sea State Agro-engineering Academy, Zernograd/Russia;
- [5] Bhanage G.B., Shahare P.U., Aware V.V., Dhandeand K.G., Deshmukh P.S., (2017), Development of stripper harvester for paddy, *Journal of Applied and Natural Science*, Issue 9(4), pp. 1943-1948. (DOI: 10.31018/jans.v9i4.1469);
- [6] Chegini G.R., Mirnezami S.V., (2012), Analysis and comparison of wheat losses in two harvesting methods, *Agricultural Engineering International: CIGR Journal*, Issue 14, pp. 91-98, Paris/France;
- [7] Chegini G.R., (2013), Determination of Optimum Operating Conditions of Combine Harvester with Stripper-Header, *World Applied Sciences Journal*, Issue 23(10), pp. 1399-1407, Pakistan (DOI 10.5829/idosi.wasj.2013.23.10.1829);
- [8] Izmajlov A.YU., SHogenov YU.H., (2017), Intensive machine technologies and new generation machinery for the production of the main groups of agricultural products (Интенсивные машинные технологии и техника нового поколения для производства основных групп сельскохозяйственной продукции), *Machinery and equipment for the village (Техника и оборудование для села)*, Issue 7, pp. 2-6, Moscow/Russia;
- [9] Khusanov I., Babaev S., Ravshanov S., Rajabova V., (2011), The effect of humidity on the grain strength of wheat of some varieties (Влияние влажности на предел прочности зерна пшеницы некоторых сортов), *Bread products (Хлебопродукты)*, Issue 2, pp. 54-55, Moscow/Russia;
- [10] Lizhang X., Yaoming L., (2011), Modeling and experiment of threshing unit of stripper combine, *African Journal of Biotechnology*, Issue 10(20), pp. 4106-4113, Nigeria (DOI 10.5897/AJB10.2211);
- [11] Moskovskij M.N., Kovaleva A.V., Kuren S.G., (2017), Using of the pneumatic blow method at the contactless threshing of grains, *ARPJN journal of engineering and applied sciences*, pp. 6414–6418, Islamabad/Pakistan;
- [12] Moskovskij M.N., Ignatenko I.V., Pahomov V.I., Lachuga YU.F., (2015), *The device for threshing the ear cultures*, Patent, No.2551163, Russia;
- [13] Patel S.R., Varshney B.P., (2016), Modeling of wheat crop harvesting losses, *Agricultural Engineering International: CIGR Journal*, Issue 16(2), pp. 97-102, Paris/France;
- [14] Shamin A.E., Zaikin V.P., Igoshin A.N., Lisina A.YU., (2018), Problems of grain harvesting in Russia (Проблемы уборки зерна в России), *Bulletin Nizhniy Novgorod State Engineering-Economic Institute (Вестник Нижегородского государственного инженерно-экономического института)*, Issue 6(85), pp. 130-138, Nizhniy Novgorod/Russia;
- [15] Yuan J., Lan Y., (2007), Development of an Improved Cereal Stripping Harvester, *Agricultural Engineering International: CIGR Journal*, Issue 9, pp. 1-12, Paris/France.