

RESEARCH STATUS OF MECHANIZED HARVESTING TECHNOLOGY AND EQUIPMENT FOR TOBACCO STALKS

烟秆机械化收获技术与装备研究现状

Shilong LI¹⁾, Hu XIE^{*1,2)}, Qimin GAO¹⁾, Minjiang CHEN¹⁾

¹⁾Nanjing Institute of Agricultural Mechanization, Ministry of Agriculture and Rural Affairs, Nanjing, Jiangsu / China;

²⁾Institute of Western Agriculture, the Chinese Academy of Agricultural sciences, Changji, Xinjiang/China

Tel: +86-15366092935; E-mail: tmjamexh@163.com

DOI: <https://doi.org/10.35633/inmateh-78-93>

Keywords: tobacco stalk; stalk harvesting and cleaning; crushing and collection; integration of machinery and technology; full mechanization; review

ABSTRACT

This study systematically investigates the key stage of tobacco stalk harvesting within China's fully mechanized tobacco production system, evaluating mainstream technical approaches and representative equipment worldwide. It identifies that progress in mechanized stalk harvesting is hindered by several challenges, including stratified leaf collection, repeated field operations, and the constraints imposed by ridge-based cultivation systems. The study clarifies the core operational processes (stalk extraction, conveyance, fragmentation, and collection) and summarizes the structural characteristics and recent developments of key domestic components. A comparative analysis of equipment performance and applicable field conditions is also presented. Finally, development recommendations are proposed in accordance with the trend toward integrated mechanization and agronomy, as well as increasing system intelligence, providing a reference for future technological innovation and practical application.

摘要

本文针对我国烟草生产全程机械化中烟秆收获这一关键环节，系统梳理了国内外烟秆机械化收获的主要技术路线与机型。文章分析了受分层采叶、多次进地及垄作地形等因素制约，烟秆机械化发展缓慢的现状，归纳了拔取、输送、粉碎、收集等关键作业机理，总结了国内核心部件的结构特点与研究进展，并比较了不同机具在作业性能与适用场景上的差异。面向“机艺融合、智能化”发展趋势提出了装备研发建议，以期对相关技术开发和推广提供参考。

INTRODUCTION

Originating in South America, tobacco has been globally disseminated (Duke et al., 2022). China is not only the world's largest tobacco producer but also its leading consumer, accounting for approximately 40% of global production (Chan et al., 2023; Cui, 2021). In recent years, China's tobacco cultivation area has stabilized at around 1 million hectares. After tobacco leaf harvesting, 2250–3000 kg of tobacco stalks remain per hectare (Du, 2017), resulting in an annual need to clear approximately 1.5 million tons of tobacco stalks nationwide (Liu et al., 2013). Key tobacco-growing regions in China include Yunnan, Guizhou, Hunan, Sichuan, and Henan, which play a pivotal role in the national tobacco industry (National Bureau of Statistics, 2023; Tang et al., 2018; Teng et al., 2024).

In recent years, research and application of tobacco mechanization in China have advanced increasingly, with the research focus gradually shifting from "yield and efficiency improvement" to "integration and specialization." Fields such as tobacco leaf visual recognition and machinery-agronomy integration have become prominent research topics (Chen et al., 2023). However, within the full mechanization chain, post-harvest stalk management and resource utilization remain enduring challenges and critical needs (Bareschino et al., 2021; Guo et al., 2019). Meanwhile, multiple regions are promoting integrated demonstration projects involving "tobacco leaf harvesting—stalk collection and shredding—resource utilization," aiming to convert tobacco stalks from agricultural waste into valuable resources, reduce disease incidence, and achieve a balance between carbon sequestration, soil fertilization, and environmentally sustainable production (Hu et al., 2024; Manthos 2025; Zou et al., 2021; Barla 2019).

Tobacco stalks are characterized by elongated internodes, high cellulose and lignin contents, considerable tensile and shear strength, high humidity sensitivity, and a tendency to slip during mechanical handling (Zheng *et al.*, 2020). These properties present significant challenges during uprooting, breaking, transportation, and processing, often leading to blockages, slippage, entanglement, and uneven fragmentation. Furthermore, plant rigidity decreases after multiple leaf-harvesting cycles, and additional complications are posed by field conditions in certain regions including hilly terrain, small fragmented plots, narrow row spacing, and interlocking ridges which complicate chassis mobility and posture control during mechanized operations (Wang *et al.*, 2023). The implementation of standardized tobacco field layouts and the adoption of machinery-compatible agronomic practices across different production areas directly affect the adaptability and operational efficiency of harvesting equipment (Stucker *et al.*, 2021; Zhang *et al.*, 2022; Zhang *et al.*, 2025).

RESEARCH PROGRESS AND ANALYSIS

1 Technical Requirements for Tobacco Stalk Harvesting

Research on tobacco stalk harvesting technology and equipment must meet the following prerequisites:

① At the end of the industrial chain, harvested stalks must comply with the raw material specifications for factory processing and be processed within the specified time frame. ② As tobacco is an annual herbaceous crop, harvesting operations must adhere to the agronomic standards for tobacco cultivation and production. ③ Mechanized harvesting technologies and equipment should be compatible with the field conditions typical of tobacco production in China. This paper first clarifies the agronomic technical specifications for tobacco stalk harvesting, then systematically reviews and summarizes research progress in technical routes, core technologies, harvester configurations, and integrated harvesting systems (Guo *et al.*, 2019; Huo *et al.*, 2023; Pandirwar *et al.*, 2022). Finally, this study analyzes the current challenges and proposes prospective research directions for mechanical harvesting technologies and equipment.

1.1 Physicochemical Properties of Tobacco Stalks in the Harvesting Window Period

In agricultural machinery design, understanding the interaction mechanism between machinery and crops is critical for reducing energy consumption and improving operational quality (Jia *et al.*, 2013). When formulating technical routes and developing key technologies for tobacco stalk mechanical harvesting, it is essential to fully grasp the physicochemical properties of tobacco stalks during the optimal harvesting window.

1.1.1 Harvesting window period: stalks, lateral buds, roots, and tips

A tobacco plant comprises four primary components: main stalk, lateral buds, roots, and terminal shoot (Zhao *et al.*, 2016). The terminal shoot refers to the 2–3 tender stalks and flowers at the top of the plant, characterized by high moisture content and low lignin levels, which result in poor mechanical properties. During harvesting, the stalk-pulling mechanism should avoid contacting the terminal shoot to prevent stalk breakage or extraction failure (Wei *et al.*, 2018). For the main stalk, non-stalk components—including lateral buds, leaves, roots, and soil—can interfere with mechanized harvesting. Therefore, the stalk-pulling mechanism should contact the stalk near the root zone during harvesting, as this region exhibits higher mechanical strength (Liu *et al.*, 2019).

1.1.2 Mechanical Properties of Tobacco Stalks in Harvesting Window Period

During harvesting, operations including tobacco stalk straightening, root removal, conveyance, crushing, and baling of collected materials must be completed. The design of these operational components requires a clear understanding of the mechanical properties of tobacco stalks (Liu *et al.*, 2024).

The mechanical properties of tobacco stalks during the optimal harvesting period significantly affect mechanized harvesting processes. Key mechanical parameters, including tensile strength, flexural strength, and shear strength, directly determine the stress distribution and operational efficiency of stalk-pulling components (Ma *et al.*, 2018). During this critical period, variations in moisture content and lignin concentration exert a substantial impact on the mechanical behavior of tobacco stalks (Liu *et al.*, 2007). Optimal moisture levels maintain stalk flexibility to reduce fracture risks, while increased lignin content enhances stalk stiffness and tensile strength, thereby facilitating efficient harvesting (Chen *et al.*, 2019; Li *et al.*, 2013). Excessive moisture or insufficient lignin, however, may lead to stalk breakage or failure to extract, compromising both yield and operational efficiency. Therefore, the development of tobacco mechanized harvesting technologies requires comprehensive consideration of these dynamic mechanical characteristics during the optimal harvesting window, along with precise selection of stalk-pulling components and operational parameters to ensure successful mechanized harvesting (Mao *et al.*, 2024).

A universal testing machine can be used to determine the strength, elastic modulus, and Poisson's ratio of the middle and lower sections of tobacco stalks under various loading conditions. The key challenge in this test is to ensure that the fixture enables accurate tensile testing without damaging the specimen or causing slippage (Zhao *et al.*, 2023). Two effective approaches to address this issue include the preparation of dumbbell-shaped tobacco stalk specimens and the use of a bonded assembly method (Guo *et al.*, 2021).

The material model of tobacco stalks can be established using a single-phase composite material model (Hamman *et al.*, 2005; Ionita, 2006; Soleimani *et al.*, 2023).

1.2 Requirements of Agronomy for Harvesting Operation Quality

1.2.1 Post-harvest stubble

Following tobacco leaf harvest, subsurface stubble residues not only impede subsequent plowing and land preparation, reducing operational efficiency and quality, but also increase pest and disease risks, negatively impacting the growth of subsequent crops (Zhao *et al.*, 2024). Therefore, effective stubble removal is critical during tobacco stalk harvesting, and whole-stalk recovery serves as a key index for evaluating harvest quality.

1.2.2 Soil compaction degree in tobacco fields

Field operations with heavy machinery frequently cause soil compaction. This disrupts soil aggregation, impairs water infiltration and root penetration, and severely reduces soil permeability and fertility (Jimenez *et al.*, 2021; Liu *et al.*, 2024), thereby inhibiting crop growth and reducing yield. To mitigate this issue, the adoption of low-impact machinery or optimized field management strategies (e.g., dedicated traffic lanes) can effectively alleviate compaction, preserving the ecological health and long-term productivity of tobacco fields (Elaoud, 2011; Hu W. *et al.*, 2018).

1.2.3 Field Losses

During tobacco stalk harvesting, all stalks in the field should be fully collected to minimize stubble and root residues.

1.3 Tobacco Stalk Harvesting Techniques

1.3.1 Manual Harvesting Techniques

Manual harvesting consists of two main procedures: stalk extraction and baling.

- ① Stalk harvesting: Tobacco stalks are extracted near ground level using a hoe or simple hand tools.
- ② Baling: Stalks are tied with hemp rope or bamboo strips for convenient transport.

1.3.2 Mechanized Harvesting Technology

(1) "Support-Pull-Transport" and "Topple-Dig-Transport"

During harvesting, tobacco stalks may be present in either upright or lodged conditions. The "Support-Pull-Transport" method first straightens lodged stalks and then feeds them into a pulling mechanism, which uproots the stalks intact. The uprooted stalks are subsequently conveyed to one side for laying or stacking. However, severely lodged stalks are difficult to straighten; therefore, this method is mainly suitable for crops with good standing conditions or moderate lodging, particularly under intercropping systems.

The "Topple-Dig-Transport" method initially topples the tobacco stalks, after which they are conveyed into a pulling device. A turning roller then uproots the stalks at a predetermined angle. This method is more effective for harvesting severely lodged tobacco stalks.

(2) In segmented mechanized harvesting, tobacco stalks are transported to a fixed location for impurity removal using specialized equipment. At present, tobacco stalk harvesting mainly relies on two techniques and their corresponding equipment: whole-stalk pulling and collection.

2 Research Status of Mechanized Harvesting Equipment for China Tobacco Stalks

Recently, through technology introduction and independent innovation, numerous research institutions and enterprises have developed various types of tobacco stalk harvesters, including both segmented and integrated systems.

2.1 Segmental Tobacco Stalk Harvester

Tobacco stalk digging harvesters are primarily designed for segmented harvesting, in which separate machines perform stalk extraction, soil separation, crushing, collection, and baling. Currently, three main types have been developed in China: digging harvesters, clamping harvesters, and vibrating harvesters.

2.1.1 Digging-type Tobacco Stalk Harvester

A tobacco stalk excavator uses digging rollers to extract tobacco stalks and roots from the soil, after which the soil-attached stalks are deposited onto the ground (Sun *et al.*, 2018).

The excavation performed by the digging mechanism represents the primary step in tobacco stalk harvesting, whose structural parameters and stress characteristics directly determine harvesting quality and efficiency. The classification, features, and representative equipment are summarized in Table 1.

Table 1

Classification and Characteristics of Tobacco Stalk Mechanized Harvesting Equipment

Harvesting Technology Type	Core Structural Features	Typical equipment	Cleaning rate	Productivity (hm ² ·h ⁻¹)
Drum-type (Rake tooth)	High adaptability, excellent excavation efficiency, minimal damage to tobacco stalks, and low risk of blockage; relatively complex structure	Yongdong YGQ-1B type tobacco harvester	93%~97%	6~10
Drum-type (blade)	The excavation exhibits strong stability and broad adaptability; however, it requires higher operational energy consumption. It is suitable for loose soils such as sandy soil.	Taishan 4JZ-50 type tobacco stalk harvester	≥93%	4~7
Turner type	It exhibits good overall performance and versatility, balancing soil penetration capability with structural strength. However, it is prone to broken stalks and jamming.	Bolais 1BGY-100 type tobacco stalk harvester	≥95%	4~12



Fig. 1 - Excavating tobacco stalk harvester

2.1.2 Clamping-type Tobacco Stalk Harvester

A clamping-type tobacco stalk harvester uses clamping devices (such as clamping belts or chains) to continuously grip the base or lower-middle section of tobacco stalks. During operation, it extracts or assists in digging stalks from the soil and conveys them to one side or directly into collection boxes (Jin et al., 2024). Key examples include the clamping-type harvester developed by (Guo et al., 2023) at Yunnan Agricultural University, the chain-clamping unit designed by (Long, 2023) in Henan, and the dual-roller double-helical harvester proposed by (Li et al., 2023) at Chongqing Tobacco Company. The operational performance and characteristics of these clamping-type harvesters are summarized in Table 2, with photographs shown in Fig.2.

Table 2

Classification and Characteristics of Tobacco Stalk Mechanized Harvesting Equipment

Harvesting Technology Type	Core Structural Features	Applicable Field Conditions
Belt clamp	The clamping area is large, causing minimal damage to the tobacco stalk and ensuring stable operation; however, the clamping force is limited and the clamping belt is prone to slipping when worn or contaminated with mud, leading to detachment.	Tobacco field with upright plants and shallow root system in sandy loam soil
Chain clamp	The clamping force is strong, the conveying is reliable, and it is less likely to slip; however, it exerts significant impact on the tobacco stalk, which may cause stalk fracture.	Various soils with tall plants and firm root systems

Harvesting Technology Type	Core Structural Features	Applicable Field Conditions
Roller clamp	It combines clamping and combing functions, enabling effective forced conveyance with strong anti-clogging capability; the structure is relatively complex, requiring high manufacturing precision.	High versatility, particularly suitable for complex working conditions such as plant lodging and entanglement.

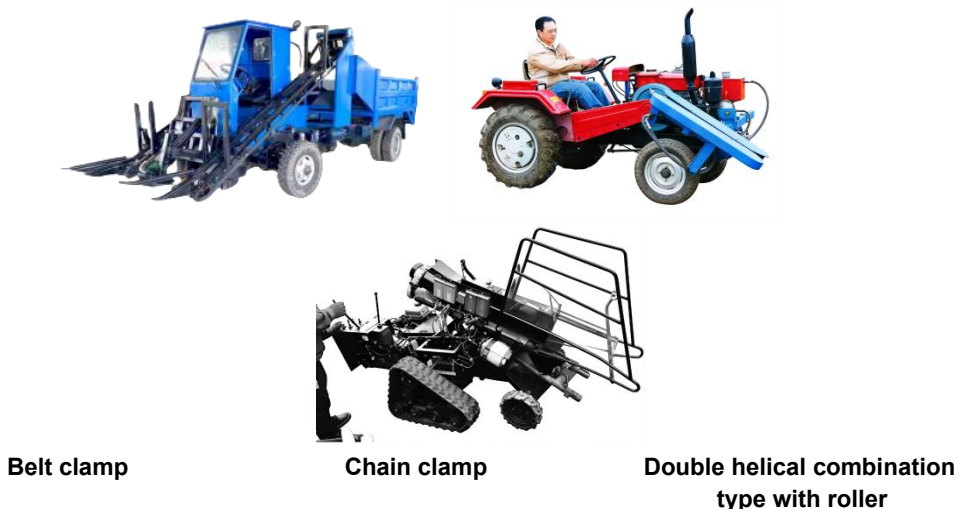

Fig. 2 - Physical image of the clamping tobacco stalk harvester

In China, clamping-type tobacco harvesters remain in the prototype development and field demonstration stage, and have not yet been widely adopted like clamping-type rice harvesters. Most research advances have been achieved by universities and research institutions, including China Agricultural University and the Nanjing Institute of Agricultural Mechanization, Ministry of Agriculture and Rural Affairs, focusing primarily on the typical upright tobacco stalks widely grown in China (Zheng, 2018). Owing to the physical properties of tobacco stalks multiple branches, brittle texture, and high slippage tendency along with the complexity of field conditions in China, the operational reliability of clamping tobacco harvesters has not been fundamentally improved (Ha et al., 2023).

2.1.3 Vibration Tobacco Stalk Harvester

A vibrating tobacco stalk harvester applies mechanical vibration at a specific frequency and amplitude to key working components (primarily the digging shovel), enabling draft reduction, soil fragmentation, and enhanced soil-stalk separation.

The traction-type tobacco stalk harvester developed by (Yin et al., 2025) at Henan Tobacco Company consists of four functional components: rotary tiller blades, conveyor chain, crushing roller, and collection device. Its main structural elements include gearbox, rolling wheels, frame, bucket, transmission chain, and ground wheels (Fig.3). The gearbox transfers power from the tractor to the sprocket, which drives the separation and feeding mechanisms via a chain drive. This arrangement conveys excavated tobacco stalks from the digging unit to the rear of the machine. During conveyance, vibration generated by the conveyor sprocket enables effective separation of tobacco stalks and surrounding soil.

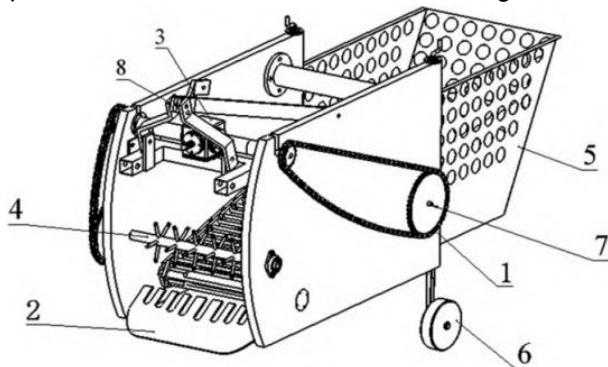

Fig. 3 - Tractor-type tobacco stalk harvester

- 1. Chain transmission; 2. Digger blade; 3. Gear reducer; 4. Feeding mechanism; 5. Collection Box;
- 6. Ground wheel; 7. Rolling shaft; 8. Three-point hitch mechanism

During soil penetration, the vibrating blade periodically changes its frictional interaction with the soil, transforming continuous static friction into intermittent dynamic friction. This greatly reduces draft resistance (by 20%–40% per experimental data) and transfers vibrational energy into the soil.

Pre-compression and lateral soil fragmentation improve excavation smoothness. In the subsequent conveying stage, vibration continues to act on separation devices such as lifting chains or oscillating screens, sustained by impact vibration wheels below. This effectively dislodges and separates soil from tobacco stalk bases. This dual vibratory synergy mechanism—“resistance reduction in excavation, soil cleaning in conveyance”—constitutes the core advantage of vibratory harvesters for enhancing operational efficiency and cleanliness (Fang *et al.*, 2025).

2.2 Tobacco stalk integrated harvester

Integrated tobacco stalk harvesters complete all operations in a single pass, including stalk extraction, clamping, soil-cleaning conveyance, crushing, and collection (Wang *et al.*, 2024; Denarda *et al.*, 2021). Two main configurations are commercially available: tractor-driven and trailer-mounted units. Both feature similar structures, including a stalk-pulling mechanism, conveyor system, crushing unit, traveling mechanism, and powertrain, with key differences in their connection and power transmission modes. The tractor-driven type employs flexible traction, with power supplied by an independent engine or the tractor’s power take-off (PTO). In contrast, the trailer-mounted type is rigidly connected to the tractor and fully powered by the PTO, allowing more direct and efficient power transmission. A typical configuration is illustrated in Fig. 4.



Fig. 4 - Integrated tobacco stalk harvester

2.2.1 Stalk-pulling Device

Research on tobacco stalk harvesting devices in China centers on three core objectives: high efficiency, low loss, terrain adaptability, and agronomic compatibility. To suit regional cultivation conditions and farming demands, three primary technical approaches have been developed. The first is the clamping method, which uses two rotating rollers or chains to grip and extract stalks. This method is well-adapted to hilly and mountainous regions but faces issues such as stalk entanglement in heavy clay soils (Jiang, 2009). The second is the excavation method, which applies deep loosening to remove stalks and root systems simultaneously. This approach effectively reduces root breakage and soil adhesion, making it suitable for large-scale tobacco production in plain areas.

Adaptive force control systems provide technical support for the innovation and development of stalk-pulling components, improving operational reliability and adaptability to variable soil conditions (Siciliano, 1993; Calanca, 2018). Meanwhile, lever-actuated labor-saving tools designed for small mountain plots exhibit distinct practical value.

2.2.2 Conveying Device

Current research in this field focuses on the efficient conveying and processing of tobacco stalks for downstream utilization, with emphasis on reducing power consumption, minimizing vibration, and improving processing quality and efficiency. Technological development has evolved from single-function implementation to overall performance optimization. Three main conveying methods are commonly used: chain-link conveying, belt-clamping conveying, and roller-clamping conveying. Chain-link conveying features a robust structure and high load-carrying capacity, making it widely used in many harvesting machines. However, it is prone to clogging when handling mixtures of tobacco stalks and weeds (Radicioni *et al.*, 2025) (Fig. 5a). Belt-clamping conveying enables orderly material transport by increasing the clamping area, thereby reducing blockage; however, it requires better alignment and uprightness of the stalks (Guo, 2023) (Fig. 5c). Roller-clamping conveying, based on forced feeding, exhibits distinct advantages in handling lodged tobacco stalks (Ra *et al.*, 2022) (Fig. 5b).

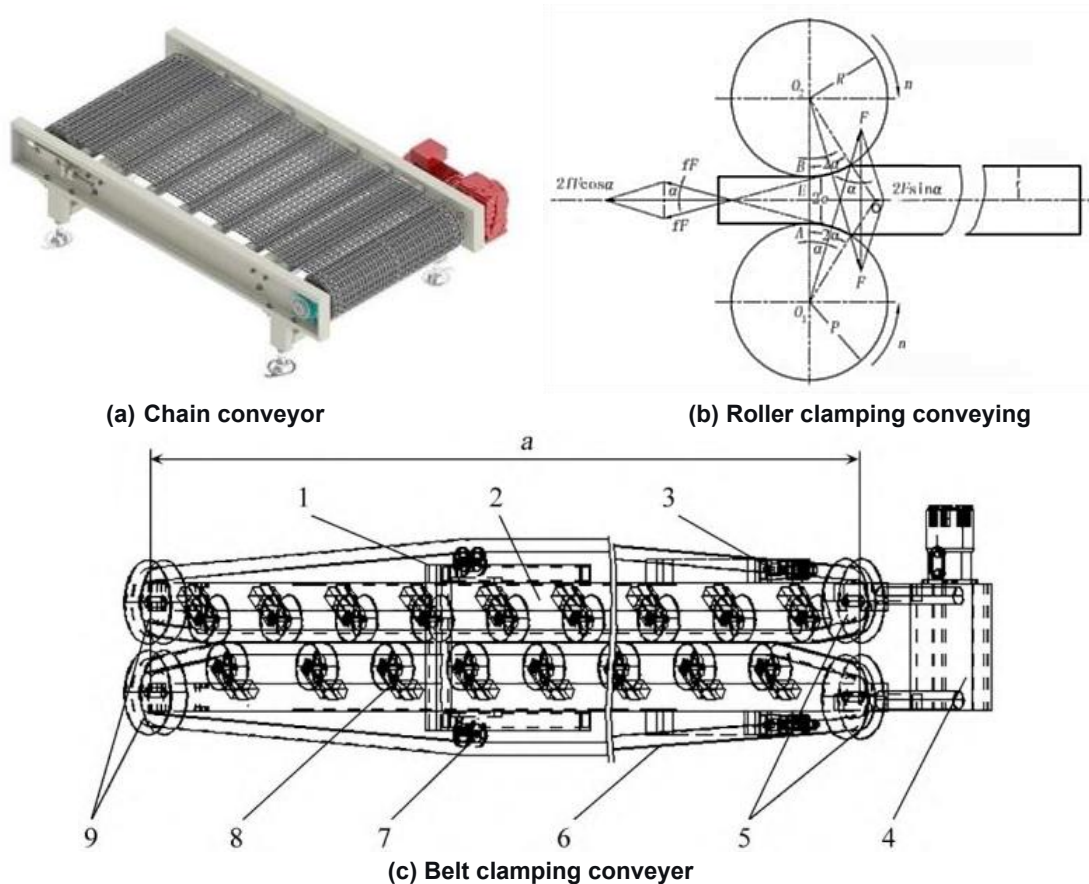

Fig. 5 - Transport Device

1. U-shaped bracket; 2. Support; 3. Bearing bracket; 4. Fluid motor; 5. Active pulley; 6. Clamping strap; 7. External tension wheel; 8. Internal tension wheel; 9. Passive pulley

Current research focuses on two key innovation areas. First, regarding structural design, optimizing conveyor inclination angles and incorporating forced-feeding mechanisms improves conveying stability. Targeted optimizations have been developed for tall, easily entangled tobacco stalks; for example, (Zhang *et al.*, 2018) designed multi-stage conveying rollers with varied tooth profiles and rotational speeds. Second, in terms of material technology, high-wear-resistance composites and anti-entanglement surface treatments are applied to extend service life. Furthermore, adaptive tensioning technology and intelligent monitoring systems allow conveying devices to automatically adjust operating parameters under varying loads, providing technical support for innovations in tobacco stalk harvester conveying systems.

2.2.3 Crushing and Collection Device

In the field of tobacco stalk harvesting machinery, traditional crushing methods based solely on cutting or hammering have shown limitations in complex operating conditions (Li *et al.*, 2021). This has promoted composite crushing technology as a mainstream research direction.

A typical example is the innovative scheme proposed by Yunnan Agricultural University, which combines the shearing action of moving blades with the impact crushing of hammer plates. This combined method effectively treats tobacco stalks with varying diameters and moisture contents, greatly improving both adaptability and crushing efficiency.

To reduce cutting resistance and energy consumption, as well as optimize cutting trajectories and the structural balance between tools and cutter rollers, *Yang et al., (2017)*, from Guizhou University designed an isoslip-angle cutting edge (Fig. 6a), and *Pu, (2015)*, from Jilin University developed a new combined Y-type throwing cutter (Fig. 6b). In addition, to alleviate the severe vibration of traditional crushers, *Zhang et al., (2020)*, from Guizhou University replaced the traditional eccentric hammer-type cutter roller with a centrally arranged disc structure (Fig. 6c), which effectively improved the dynamic balance and significantly enhanced operational stability (*Yu, 2018*).

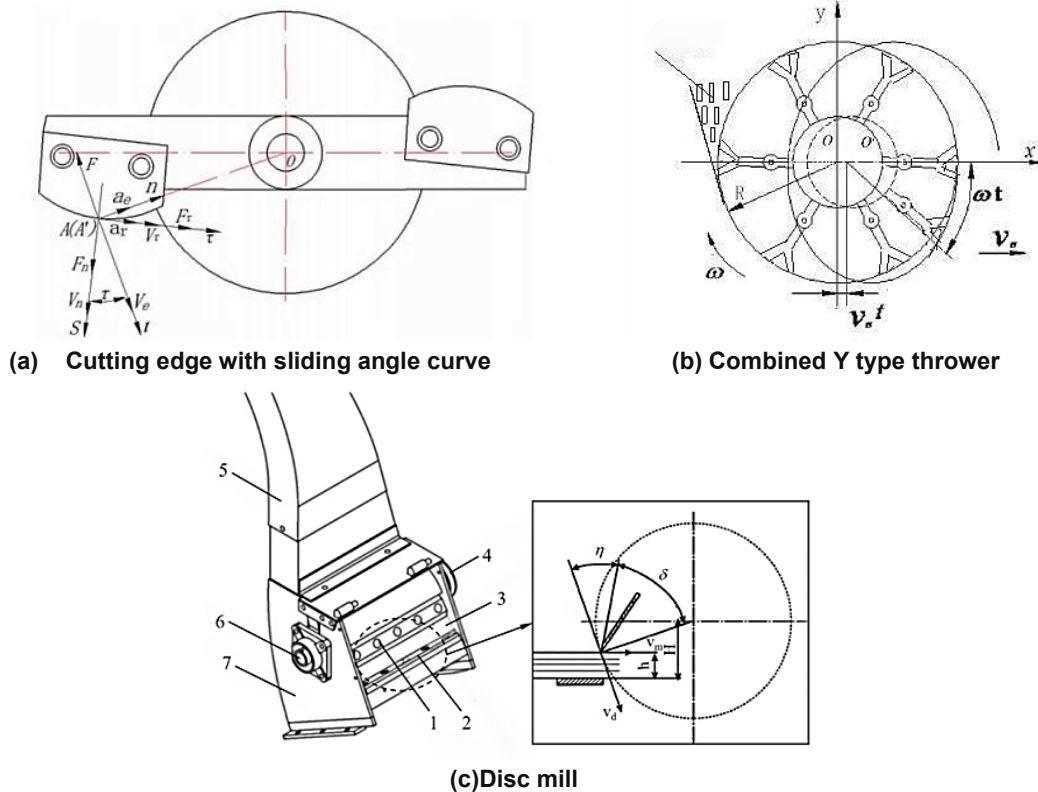

Fig. 6 - Structural diagram of key components in the crusher
 1. Knife section; 2. Fixed blade; 3. Rotary flywheel drum; 4. Pulley;
 5. Discharge port; 6. Roller knife spindle; 7. Crushing chamber

With advances in hardware architecture, simulation-based internal flow field optimization and parameter matching using modern experimental methods have attracted increasing attention. Through computational fluid dynamics (CFD) analysis of material flow within the crushing chamber, *Yang (2018)* from Guizhou University optimized the airflow distribution, thereby addressing issues such as discharge blockage and low operating efficiency. Using response surface methodology and related experimental techniques, the study further optimized key parameters, including cutter roller speed and machine travel speed, to determine the optimal operating range for reducing tobacco stalk losses and improving crushing quality.

Table 3

Classification and Characteristics of Tobacco Stalk Mechanized Harvesting Equipment

Harvesting Technology Type	Core Structural Features
Chopping type	Tobacco stalks are cut by the shearing action between moving and stationary blades. The resulting fragments are relatively uniform, and power consumption is low; however, hard nodes may lead to tool wear and edge chipping.
Hammering type	High-speed rotating hammer blades are used to crush tobacco stalks. This method exhibits strong adaptability and high crushing efficiency, particularly for hard nodes and soil-root stubble, and is less prone to blockage. However, the resulting fragments are irregular in shape, generate significant dust, and involve high energy consumption.

Harvesting Technology Type	Core Structural Features
Shredding type	Tobacco stalks are processed through the tearing and kneading action between a low-speed rotating toothed roller and fixed teeth. This method provides gentle processing with longer fragments, which is beneficial for subsequent fermentation; however, productivity is relatively low, and the stalks are prone to entanglement.

2.2.4 Traveling mechanism

The traveling mechanism of integrated tobacco stalk harvesters is a critical component, enabling field mobility and terrain adaptation (Huang *et al.*, 2020). It is primarily categorized into two configurations: wheeled and tracked. These designs differ significantly in their application scenarios, structural layouts, and operational performance.

Wheeled traveling mechanisms feature a simple structure and ease of maintenance, making them widely adopted in large-scale, flat tobacco fields with solid soil (Bao *et al.*, 2023). Structurally, wheel frames are typically mounted on both sides of the rear frame, with traveling wheels directly attached to facilitate machine movement. These systems generally lack a complex independent drive structure, instead coordinating with the harvester's main power transmission system sharing components such as those for the stalk-pulling knife roller and conveyor chain to achieve locomotion. However, wheeled designs have a relatively small ground contact area, making them prone to slippage and sinking in waterlogged or muddy fields. Additionally, their terrain adaptability is limited in areas with significant undulations, rendering them suitable primarily for operations in plain tobacco fields.

Crawler undercarriages are well-suited for complex terrains—such as hilly mountains and waterlogged tobacco fields—and represent a standard design for modern integrated tobacco stalk harvesters. Structurally, they comprise a drive motor, track drive shaft, drive gears, idler wheels, and tracks. In typical configurations, idler wheels and drive gears form a triangular support structure (with the latter as the vertex), enhancing traveling stability. Each track plate features a drive hole that engages with the drive gear's teeth, ensuring robust power transmission. Some models incorporate additional track wheels mounted externally on the front and rear side plates of the frame. On each side, these wheels are encircled by a synchronous transmission track, further improving synchronization during linear travel and turning. For example, Zhang *et al.*, (2015), experimentally validated the feasibility of an unsteady steering model for heavy-duty all-terrain triple-track robots in predicting the steering performance of crawler undercarriages. The crawler design increases the machine's ground contact area, effectively reducing ground pressure and preventing subsidence in soft tobacco fields. Its strong terrain adaptability enables it to navigate slopes and undulations in hilly regions, aligning with the characteristics of tobacco cultivation in mountainous areas of China (Yuan *et al.*, 2024).

3. Research Status of Mechanized Harvesting of tobacco stalks abroad

Globally, the United States and Japan were early pioneers in tobacco stubble removal, boasting advanced technological capabilities.

U.S. tobacco fields are primarily distributed across the Southeast and Central South plains, where flat terrain, large-scale farmland, favorable climatic conditions, and a mature agricultural mechanization system provide a strong foundation for large-scale, mechanized tobacco stalk harvesting operations (Fang, 2016; Wu, 2020). For example, John Deere's P-1216 tobacco stalk harvester (see Fig. 8), when tractor-mounted, uses a circular cutter to sever entire tobacco stalks at the root. It can complete 16 rows of root-pulling in a single pass, delivering wide working width and high efficiency, making it well-suited for large-scale, flat tobacco cultivation operations.



Fig. 8 - P-1216 tobacco stalk harvester

Due to its limited land area, Japan has relatively small, scattered tobacco cultivation plots. Consequently, its machinery prioritizes lightness and flexibility. Since the 1960s, the Japan Tobacco Cultivation Machinery Association has collaborated with enterprises to research tobacco cultivation mechanization, successfully achieving full mechanization of the entire cultivation process. During this development, tobacco stalk harvesting machinery emerged, marking the initial integration of tobacco stalk farming machinery and agronomy (Lü, 2013; Yang, 2018). For example, Wenming Agricultural Machinery Co., Ltd.'s KB-10 tobacco stalk harvester is tractor-matched and uses a chain-type clamping method to complete stalk harvesting, crushing, collection, and transportation in one pass. Jingguan Agricultural Machinery Co., Ltd.'s RDT-80, when paired with a 20–30 hp tractor, uses a reverse-rotating root-pulling tool to directly cut and dig out tobacco stalks, demonstrating excellent operational efficiency (Shu, 2019) (as shown in Fig.9). Additionally, models like the KB-3C and BTM-2000 offer good stability, ease of operation, and strong adaptability.



(a)KB-10 (b) RDT-80

Fig. 9 - Japanese tobacco stalk harvester

4 Comparison of technical Characteristics of Domestic and Foreign mechanical harvesting equipment for Tobacco stalks

(1) Tobacco stalk harvesters differ significantly across countries, shaped by topography, landforms, and tobacco varieties. The United States deploys large-scale, highly automated mechanized systems, while major producers like Brazil rely primarily on digging-based harvesting. In China, small-scale operations dominate and are widely adopted under the mature segmented operation model. Combined harvesters have also been promoted in specific regions but lack innovation in core technologies. Additionally, the batch harvesting models for tobacco leaves used in developed countries (e.g., the U.S.) are incompatible with China's operational needs (Yorifuji et al., 2011).

(2) Tobacco stalk harvesters have limited versatility globally. In developed nations like the U.S., large-scale farming, standardized planting, and highly adaptable equipment are standard. By contrast, China's tobacco cultivation lacks a unified model, resulting in inconsistent equipment working widths and reduced universal applicability (Pan et al., 2012; Wang et al., 2021; Zhang et al., 2018).

(3) Mechanized harvesting technical models also vary. The U.S. benefits from regionally optimized tobacco cultivation and standardized agronomic norms, so tobacco stalk harvesting is integrated with leaf harvesting in a combined operation mode that simultaneously clears field stalks (Fisher, 2000). In China, however, the extensive growing areas, diverse soil types, complex planting terrains, and variable meteorological conditions during harvest create a far more complex and diverse operational landscape.

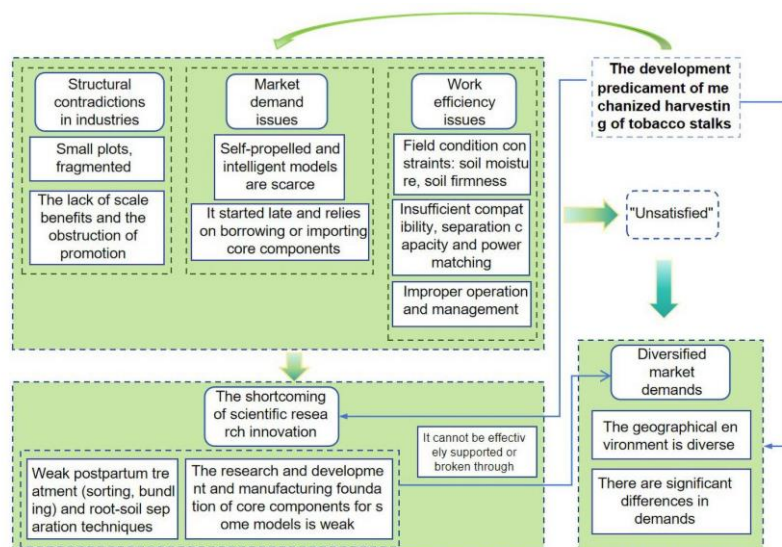

Fig. 10 - Problems in the mechanized harvesting of China tobacco stalks

DEVELOPMENT STRATEGIES AND TRENDS

Development Strategies

Against the backdrop of China's "New Quality Productivity in Agriculture" initiative (2025), which emphasizes technology-driven modernization, digitalization, and green transformation, the research, development, and upgrading of tobacco stalk harvesting machinery are critical to supporting this national strategy. To address current bottlenecks—including low mechanization levels, immature core technologies, limited adaptability, high costs, and inconsistent product quality—a comprehensive development approach is required, integrating technological innovation, industrial coordination, policy support, and multi-stakeholder participation.

A phased and targeted strategy is proposed:

(1) Core technology breakthroughs

Priority should be given to the research and development of intelligent, cost-effective, and highly adaptable harvesting equipment, with a focus on key components such as precision cutting mechanisms, real-time quality monitoring systems, and energy-efficient power units.

(2) Standardization and scaling

Unified agronomic and mechanical standards should be established to promote large-scale mechanized tobacco stalk collection and utilization. At the same time, demonstration zones for integrated harvesting and processing technologies should be expanded.

(3) Service system improvement

A comprehensive after-sales service and technical support system should be developed to reduce operational barriers for smallholder farmers and agricultural cooperatives.

Development Trends

Tobacco stalk harvesting is transitioning from a passive "disposal" model to an active "resource utilization" paradigm, driven by technological innovation and market demand. In the short to medium term, the sector is expected to exhibit three major development trends:

(1) High efficiency and intelligence

The integration of artificial intelligence (AI) and Internet of Things (IoT) technologies will enable real-time monitoring of crop conditions, adaptive control of harvesting parameters, and predictive maintenance, thereby significantly improving operational efficiency and reducing labor requirements.

(2) Sustainability and multifunctionality

Harvesting equipment will increasingly integrate functions such as crushing, collection, and in situ processing to support applications in biorefining, circular agriculture, and bioenergy utilization, thereby enhancing the economic value of tobacco stalk resources.

(3) Integration and systemization

Harvesting machinery will become an integral component of smart agricultural systems, interconnected with precision farming technologies, supply chain management, and carbon accounting platforms, thereby enabling data-driven decision-making across the entire value chain.

REFERENCES

- [1] Duke, D., Wohlgemuth, E., Adams, K.R., Armstrong-Ingram, A., Rice, S.K., & Young, D.C. (2022). Earliest evidence for human use of tobacco in the Pleistocene Americas. *Nature Human Behaviour*, 6(2), 183–192. <https://doi.org/10.1038/s41562-021-01202-9>
- [2] Chan, K. H., Xiao, D., Zhou, M., Peto, R., & Chen, Z. (2023). Tobacco control in China. *The Lancet Public Health*, 8(12), e1006–e1015. [https://doi.org/10.1016/S2468-2667\(23\)00242-6](https://doi.org/10.1016/S2468-2667(23)00242-6)
- [3] Cui X. (2021). The current situation, characteristics and future prospects of China's tobacco industry. *China Circulation Economy*, (29), 8–10. <https://doi.org/10.16834/j.cnki.issn1009-5292.2021.29.031>
- [4] Du W. (2017). Research on the Application of Tobacco Waste in Agricultural Production (烟草废弃物在农业生产上的应用研究). *Rural Science and Technology*, (4), 73–74. <https://doi.org/10.19345/j.cnki.1674-7909.2017.04.041>
- [5] Liu C., Zhai X., Xu Z., Chen X., & Yang S. (2013). Research Progress on the resource Utilization of tobacco stalks (关于烟秆资源化利用的研究进展). *Acta Agriculturae Jiangxi*, 25(12), 116–119. <https://doi.org/10.19386/j.cnki.jxnyxb.2013.12.029>
- [6] National Bureau of Statistics. (2023). China Statistical Yearbook 2023. Beijing: *China Statistics Press*, pp.12–10. China

- [7] Tang, S., Li, V. C., Cui, Y., Sun, J. & Khoo, K. (2018). Successful experience with tobacco crop substitution in Yuxi, Yunnan, China. *Tobacco Induced Diseases*, 16(1), 949. <https://doi.org/10.18332/tid/84725>
- [8] Teng, L., Jiang, G., Ding, Z., Wang, Y., Liang, T., Zhang, J., Dai, H., & Cao, F. (2024). Evaluation of tobacco-planting soil quality using multiple distinct scoring methods and soil quality indices. *Journal of Cleaner Production*, 441, 140883. <https://doi.org/10.1016/j.jclepro.2024.140883>
- [9] Chen, Y., Bin, J., & Kang, C. (2023). Application of machine vision and convolutional neural networks in discriminating tobacco leaf maturity on mobile devices. *Smart Agricultural Technology*, 5, 100322. <https://doi.org/10.1016/j.atech.2023.100322>
- [10] Bareschino, P., Marrasso, E., & Roselli, C. (2021). Tobacco stalks as a sustainable energy source in civil sector: Assessment of techno-economic and environmental potential. *Renewable Energy*, 175, 373–390. <https://doi.org/10.1016/j.renene.2021.04.101>
- [11] Guo, G.-N., Yang, B.-B., Zhang, Q.-M., & Zhang, C. (2019). Porous carbon from tobacco stalk for removal of organic dyes from water. *RSC Advances*, 9(58), 33848–33852. <https://doi.org/10.1039/C9RA06688H>
- [12] Hu, N., Liu, X., Wei, S., Yao, J., Wang, W., Liu, B., Tang, T., Jiang, J., & Wang, L. (2024). Current status and future prospects of pretreatment for tobacco stalk lignocellulose. *Frontiers in Bioengineering and Biotechnology*, 12. <https://doi.org/10.3389/fbioe.2024.1465419>
- [13] Manthos, G., & Tsigkou, K. (2025). Upscaling of tobacco processing waste management: A review and a proposed valorization approach towards the biorefinery concept. *Journal of Environmental Management*, 387, 125942. <https://doi.org/10.1016/j.jenvman.2025.125942>
- [14] Zou, X., Bk, A., Abu-Izneid, T., Aziz, A., Devnath, P., Rauf, A., Mitra, S., Emran, T. B., Mujawah, A. A. H., Lorenzo, J. M., Mubarak, M. S., Wilairatana, P., & Suleria, H.A.R. (2021). Current advances of functional phytochemicals in *Nicotiana* plant and related potential value of tobacco processing waste: A review. *Biomedicine & Pharmacotherapy*, 143, 112191. <https://doi.org/10.1016/j.biopha.2021.112191>
- [15] Barla, F. G., & Kumar, S. (2019). Tobacco biomass as a source of advanced biofuels. *Biofuels*, 10(3), 335–346. <https://doi.org/10.1080/17597269.2016.1242684>
- [16] Zheng, X., Song, W., Guan, E., Wang, Y., Hu, X., Liang, H., & Dong, J. (2020). Response in Physicochemical Properties of Tobacco-Growing Soils and N/P/K Accumulation in Tobacco Plant to Tobacco Straw Biochar. *Journal of Soil Science and Plant Nutrition*, 20(2), 293–305. <https://doi.org/10.1007/s42729-019-00108-w>
- [17] Wang D., Liu Y., Liu J., Chen K., Wang Y., Du C., Du Y., & Ma X. (2023). Research Progress of Furrow and Ridge Rain-Harvesting Farming Technology and its Application Prospects in Flue-Cured Tobacco Production. *Crops*, 39(1), 1–5. <https://doi.org/10.16035/j.issn.1001-7283.2023.01.001>
- [18] Stucker, A. M., Morris, E., Stubbs, C. J., & Robertson, D. J. (2021). The Crop Clamp – A non-destructive electromechanical pinch test to evaluate stalk lodging resistance. *HardwareX*, 10, e00226. <https://doi.org/10.1016/j.ohx.2021.e00226>
- [19] Zhang, Y., Li, R., Shang, G., Zhu, H., Wang, H., Pandiselvam, R., Lei, D., Ai, Z., & Liu, Y. (2022). Effects of multiscale-mechanical fragmentation on techno-functional properties of industrial tobacco waste. *Powder Technology*, 402, 117327. <https://doi.org/10.1016/j.powtec.2022.117327>
- [20] Zhang T., Chen Q., & Yang C. (2025). Current Status and Development Trends of Tobacco-Agricultural Machinery-Agronomy Integration (烟草农机农艺融合现状及发展趋势). *China Southern Agricultural Machinery*, 56(8), 64–67.
- [21] Guo, G.-N., Cai, B., Li, R., Pan, X., Wei, M., & Zhang, C. (2019). Enhancement of saccharification and ethanol conversion from tobacco stalks by chemical pretreatment. *Biomass Conversion and Biorefinery*, 11(4), 1085–1092. <https://doi.org/10.1007/s13399-019-00478-2>
- [22] Huo, P., Ma, S., Su, C., Ding, Z., Li, W., Qian, J., Li, L., Li, Y., Zhou, B., Peng, C., & Li, W. (2023). Sugarcane leaf-stalk separating technology: A critical review. *Biosystems Engineering*, 228, 120–148. <https://doi.org/10.1016/j.biosystemseng.2023.03.009>
- [23] Pandirwar, A. P., Khadatkar, A., Mehta, C. R., Majumdar, G., Idapuganti, R., Mageshwaran, V., & Shirale, A. O. (2022). Technological Advancement in Harvesting of Cotton Stalks to Establish Sustainable Raw Material Supply Chain for Industrial Applications: A Review. *BioEnergy Research*, 16(2), 741–760. <https://doi.org/10.1007/s12155-022-10520-3>
- [24] Jia, H., Li, C., Zhang, Z., & Wang, G. (2013). Design of Bionic Saw Blade for Corn Stalk Cutting. *Journal of Bionic Engineering*, 10(4), 497–505. [https://doi.org/10.1016/s1672-6529\(13\)60242-5](https://doi.org/10.1016/s1672-6529(13)60242-5)

- [25] Zhao D., Dai Y., Feng G., Yang J., Tan L., & Li J. (2016). Chemical composition, fiber morphology and biological structure of tobacco stalks (烟秆的化学成分、纤维形态与生物结构). *Tobacco Science and Technology*, 49(4), 80–86. <https://doi.org/10.16135/j.issn1002-0861.20160413>
- [26] Wei, S., Tian, B.-Q., Jia, H.-F., Zhang, H.-Y., He, F., & Song, Z.-P. (2018). Investigation on water distribution and state in tobacco leaves with stalks during curing by LF-NMR and MRI. *Drying Technology*, 36(12), 1515–1522. <https://doi.org/10.1080/07373937.2017.1415349>
- [27] Liu W., Zhang D., Shu C., Cao Y., Li G., & Zhang Y. (2019). Experimental Study on Mechanical Properties of Tobacco Stalks (烟秆力学特性试验研究). *Jiangsu Agricultural Science*, 47(9), 252–257. <https://doi.org/10.15889/j.issn.1002-1302.2019.09.059>
- [28] Liu Q., Huang Y., Jiang J., & Wu T. (2024). A Review of Mechanized Sugarcane Harvesting Technology and Equipment (甘蔗机械化收获技术与装备研究综述). *Journal of Agricultural Machinery*, 55(12), 1–21. China.
- [29] Ma, Y., Wu, S., Zhuang, J., Tong, J., Xiao, Y., & Qi, H. (2018). The Evaluation of Physio-Mechanical and Tribological Characterization of Friction Composites Reinforced by Waste Corn Stalk. *Materials*, 11(6), 901. <https://doi.org/10.3390/ma11060901>
- [30] Liu Q., Qu Y., Qing S., & Wang W. (2007). Advances in the Study of Mechanical Properties of Crop Stalks (农作物茎秆的力学特性研究进展). *Journal of Agricultural Machinery*, 7, 172–176. China.
- [31] Li, X., Wang, S., Du, G., Wu, Z., & Meng, Y. (2013). Variation in physical and mechanical properties of hemp stalk fibers along height of stalk. *Industrial Crops and Products*, 42, 344–348. <https://doi.org/10.1016/j.indcrop.2012.05.043>
- [32] Chen, J., Zhao, N., Fu, N., Li, D., Wang, L., & Chen, X. D. (2019). Mechanical Properties of Hulless Barley Stalk with Different Moisture Contents. *International Journal of Food Engineering*, 15(1–2). <https://doi.org/10.1515/ijfe-2018-0033>
- [33] Mao, W., Yao, Z., Zhang, H., Liao, H., Li, J., Xue, D., Yuan, G., Xu, B., Dou, K., Sheng, S., Xu, C., Pang, J., Tan, X., Chi, B., & Xiong, D. (2024). Analysis of starch content and multi-scale structure of reconstituted cut stalks in tobacco. *Biomass Conversion and Biorefinery*. <https://doi.org/10.1007/s13399-024-05911-9>
- [34] Zhao, W., Chen, M., Xie, J., Cao, S., Wu, A., & Wang, Z. (2023). Discrete element modeling and physical experiment research on the biomechanical properties of cotton stalk. *Computers and Electronics in Agriculture*, 204, 107502. <https://doi.org/10.1016/j.compag.2022.107502>
- [35] Guo, J., Karkee, M., Yang, Z., Fu, H., Li, J., Jiang, Y., Jiang, T., Liu, E., & Duan, J. (2021). Discrete element modeling and physical experiment research on the biomechanical properties of banana bunch stalk for postharvest machine development. *Computers and Electronics in Agriculture*, 188, 106308. <https://doi.org/10.1016/j.compag.2021.106308>
- [36] Hamman, K. D., Williamson, R. L., Steffler, E. D., Wright, C. T., Hess, J. R., & Pryfogle, P. A. (2005). Structural analysis of wheat stalks. *Applied Biochemistry and Biotechnology*, 121(1–3), 0071–0080. <https://doi.org/10.1385/abab:121:1-3:0071>
- [37] Ionita, A., & Weitsman, Y.J. (2006). On the mechanical response of randomly reinforced chopped-fibers composites: Data and model. *Composites Science and Technology*, 66(14), 2566–2579. <https://doi.org/10.1016/j.compscitech.2006.01.019>
- [38] Soleimani, N., Kamandar, M. R., Khoshnam, F., & Soleimani, A. (2023). Defining and modelling sesame stalk shear behaviour in harvesting by reciprocating cutting blade. *Biosystems Engineering*, 229, 44–56. <https://doi.org/10.1016/j.biosystemseng.2023.03.008>
- [39] Zhao W., Xie J., Chen M., Gao Q., Cao S., Wang Z., & Chen Y. (2024). Design and Experimental Study of a Variable-Stiffness Clamp-Pulling Device for Whole Plant Cotton Stalk Harvesting (变刚度夹拔式棉秆整株拔取装置设计与试验). *Journal of Agricultural Engineering*, 40(20), 35–45. <https://link.cnki.net/urlid/11.2047.s.20241014.0904.020>
- [40] Jimenez, K. J., Rolim, M. M., de Lima, R. P., Cavalcanti, R. Q., Silva, Ê. F. F., & Pedrosa, E. M. R. (2021). Soil Physical Indicators of a Sugarcane Field Subjected to Successive Mechanised Harvests. *Sugar Tech*, 23(4), 811–818. <https://doi.org/10.1007/s12355-020-00916-w>
- [41] Liu C., Li J., Wang H., Peng Z., Duan M., He W., Sun C., & Zhou D. (2024). Current Status and Countermeasures of Mechanical Tobacco Harvesting (烟叶机械采收发展现状及对策分析). *Southern Agricultural Machinery*, 55(10), 24–28, 32. China

- [42] Elaoud, A., & Chehaibi, S. (2011). Soil Compaction Due to Tractor Traffic. *Journal of Failure Analysis and Prevention*, 11(5), 539–545. <https://doi.org/10.1007/s11668-011-9479-3>
- [43] Hu, W., Tabley, F., Beare, M., Tregurtha, C., Gillespie, R., Qiu, W., & Gosden, P. (2018). Short-Term Dynamics of Soil Physical Properties as Affected by Compaction and Tillage in a Silt Loam Soil. *Vadose Zone Journal*, 17(1), 1–13. <https://doi.org/10.2136/vzj2018.06.0115>
- [44] Sun, Q., Sui, Y., Zhao, L., Hou, J., Wang, C., Ying, C., & Shangguan, J. (2018). Design and Development of Self-Propelled Garlic Harvester. *Agricultural Research*, 7(4), 495–505. <https://doi.org/10.1007/s40003-018-0340-8>
- [45] Jin, Y., Wang, J., Chen, J., Song, Z., Zhang, R., & Zhou, R. (2024). Design and Experiment for Flexible Clamping and Conveying Device for Green Leafy Vegetable Orderly Harvester. *Agriculture*, 14(6), 967. <https://doi.org/10.3390/agriculture14060967>
- [46] Guo T., Zhang Q., Wang X., Yang B., Yin Z., Liu H., Luo K., & Shi L. (2023). Design and Experimental Study of Field Tobacco stalk harvesting Machinery (田间烟秆清理机械设计试验). *Agricultural Engineering*, 13(9), 89–96. <https://doi.org/10.19998/j.cnki.2095-1795.2023.09.015>
- [47] Long J. (2023). *Design and Research of a Portable Tobacco Stalk Puller for Hilly and Mountainous Areas* (轻便式丘陵山地烟草拔秆机的设计与研究). Southwest University. <https://doi.org/10.27684/d.cnki.gxndx.2023.000784>
- [48] Li X., Xie S., Che F., Li M., Wu S., Liu Q., Xu H., Cai M., & Yuan Y. (2023). Design and Experiment of Integrated Tobacco Stalk Pulling and Crushing Machine (拔秆粉碎一体化烟草拔秆机设计与试验). *China Agricultural Machinery Equipment*, 12, 6–10. China
- [49] Zheng W. (2018). *Theoretical and Experimental Research on Tobacco Stalk and Root Removal Machine* (烟草除秆清根机理论与试验研究) [Doctoral Dissertation, China Agricultural University]. <https://kns.cnki.net/KCMS/detail/detail.aspx?dbcode=CDFD&dbname=CDFDLAST2018&filename=1018069376.nh>
- [50] Ha, M.G., Kwon, T.Y., Cho, K.I., & Ahn, J.H. (2023). Evaluation of flexural behavior of steel pile connected with clamp-type mechanical connector. *Journal of Constructional Steel Research*, 206, 107935. <https://doi.org/10.1016/j.jcsr.2023.107935>
- [51] Yin G., Li J., Zhang Y., Chen X., Chen L., Guo Q., Wang J., Zhang H., & Yang L. (2025). Design and Research of stalk harvesting Machine for Deep-Loosening and Digging Tobacco Fields (深松挖掘式烟田拔秆机设计研究). *Agriculture and Technology*, 45(2), 67–71. <https://doi.org/10.19754/j.nyyjs.20250130015>
- [52] Fang, H., Li, J., Zhang, Q., Cheng, G., Lu, J., & Zhang, J. (2025). Design and Experiment for a Crawler Self-Propelled Potato Combine Harvester for Hilly and Mountainous Areas. *Agriculture*, 15(16), 1748. <https://doi.org/10.3390/agriculture15161748>
- [53] Wang, Y., Yang, C., Gao, Y., Lei, Y., Ma, L., & Qu, A. (2024). Design and Testing of an Integrated Lycium barbarum L. Harvester. *Agriculture*, 14(8), 1370. <https://doi.org/10.3390/agriculture14081370>
- [54] Denarda, A.R., Bertetto, A.M., & Carbone, G. (2021). Designing a Low-Cost Mechatronic Device for Semi-Automatic Saffron Harvesting. *Machines*, 9(5), 94. <https://doi.org/10.3390/machines9050094>
- [55] Jiang F., & Chen D. (2009). The Current Situation and Countermeasures of Tobacco Mechanization Development in Hilly Tobaceous Areas of China. *Journal of Anhui Agricultural Sciences*, 37(5), 2309–2310, 2321. <https://doi.org/10.13989/j.cnki.0517-6611.2009.05.163>
- [56] Siciliano, B., & Villani, L. (1993). An adaptive force/position regulator for robot manipulators. *International Journal of Adaptive Control and Signal Processing*, 7(5), 389–403. <https://doi.org/10.1002/acs.4480070508>
- [57] Calanca, A., & Fiorini, P. (2018). Understanding Environment-Adaptive Force Control of Series Elastic Actuators. *IEEE/ASME Transactions on Mechatronics*, 23(1), 413–423. <https://doi.org/10.1109/TMECH.2018.2790350>
- [58] Radicioni, L., Bono, F. M., & Cinquemani, S. (2025). On the use of vibrations and temperatures for the monitoring of plastic chain conveyor systems. *Mechanical Systems and Signal Processing*, 223, 111935. <https://doi.org/10.1016/j.ymssp.2024.111935>
- [59] Guo T. (2023). *Design and Research of Key Components for Field Tobacco Stalk Cleaning Machinery* (田间烟秆清理机械关键部件设计与研究) [Yunnan Agricultural University]. <https://doi.org/10.27458/d.cnki.gynyu.2023.000636>

- [60] Ra, Y., Kim, J., Kim, H., Cho, S., Lee, D., Jang, S., Kam, D., La, M., Park, S. J., & Choi, D. (2022). Smart conveyor roller system for self-powered product size identification in electrically off-grid condition via hybridization of triboelectric-electromagnetic generators. *Nano Energy*, 100, 107447. <https://doi.org/10.1016/j.nanoen.2022.107447>
- [61] Zhang D., Yu Z., Shu C., Liu W., Huang D., Cao Y., & Zhang J. (2018). Design and Simulation of an Integrated Tobacco Stalk Picking and Crushing Machine (一体式烟秆拔秆粉碎机设计与仿真). *Agricultural Mechanization Research*, 40(10), 75–81. <https://doi.org/10.13427/j.cnki.njyi.2018.10.014>
- [62] Li W., Ma X., Zhang J., & Yang C. (2021). Comprehensive treatment and effective utilization of crop straw (农作物秸秆综合处理及有效利用). *China Science and Technology Information*, (16), 41–42. China.
- [63] Yang K., Zhao L., Zhang D., Cao Y., & Hu H. (2017). Optimization Design of Blade Curve for Straw Crusher (秸秆粉碎机刀刃曲线的优化设计). *Mechanical Design and Research*, 33(6), 130–133. <https://doi.org/10.13952/j.cnki.jofmdr.2017.0258>
- [64] Pu Y. (2015). *Parameter design and simulation analysis of the picking and crushing device for 9YG-2.0 round bale baler (9YG-2.0 型圆捆打捆机捡拾粉碎装置参数设计与仿真分析)*. Jilin University. <https://kns.cnki.net/KCMS/detail/detail.aspx?dbcode=CMFD&dbname=CMFD201502&filename=1015600597.nh>
- [65] Zhang D., Shu C., Yu Z., Liu W., Cao Y., & Wei J. (2020). Improved Design and Blade-Roller Power Consumption Simulation of Tobacco Stalk Puller (烟秆拔秆粉碎机的改进设计与刀辊功耗仿真). *Agricultural Mechanization Research*, 42(3), 61–69. <https://doi.org/10.13427/j.cnki.njyi.2020.03.010>
- [66] Yu Z. (2018). *Development and Testing of the Rod-pulling Mechanism for a Mobile Rod-pulling and Crushing Machine (移动式烟秆拔秆破碎机拔秆机构的研制及试验)*. Guizhou University. <https://kns.cnki.net/KCMS/detail/detail.aspx?dbcode=CMFD&dbname=CMFD201901&filename=101846957.nh>
- [67] Yang K. (2018). *Optimization of the crushing device and hydraulic system design for the stalk crusher (拔秆粉碎机粉碎装置优化及液压系统设计)*. Guizhou University. <https://kns.cnki.net/KCMS/detail/detail.aspx?dbcode=CMFD&dbname=CMFD201901&filename=1018846943.nh>
- [68] Huang, J., Shen, C., Ji, A., Tian, K., Zhang, B., Li, X., & Chen, Q. (2020). Design and test of two-wheeled walking hemp harvester. *International Journal of Agricultural and Biological Engineering*, 13(1), 127–137. Retrieved from <https://ijabe.org/index.php/ijabe/article/view/5223>
- [69] Bao Y., Zhang J., & Zhao Y. (2023). Recent Patent for Walking Device of Corn Harvester. *Recent Patents on Engineering*, 17(6), 63–73. <https://doi.org/10.2174/1872212117666221107142052>
- [70] Zhang X., Huang F., & Ye J. (2015). Analysis of Steering Performance of a Heavy-Duty All-Terrain Robot's Treaded Walking Device (一种重载全地形机器人履带行走装置转向性能分析). *World Science and Technology Research and Development*, 37(5), 560–563. <https://doi.org/10.16507/j.issn.1006-6055.2015.05.020>
- [71] Yuan, L., Tang, Z., Liu, S., Wang, T., & Ding, Z. (2024). Design for Copying Grouser and Bionic Convex Hull Patterns on Track Surfaces of Crawler Combine Harvesters. *Agriculture*, 14(7), 1079. <https://doi.org/10.3390/agriculture14071079>
- [72] Wu H., & Fang X. (2020). Research on the Scientific and Technological Innovation Development of China's Agricultural Equipment Industry in the New Era (新时期我国农业装备产业科技创新发展研究). *Agricultural Engineering*, 10(5), 1–7.
- [73] Fang W. (2016). American Agricultural Mechanization Equipment and Development Trends (美国农业机械化装备与发展趋势). *Fujian Agricultural Machinery*, 2, 48–52. China
- [74] Yang Y., & Chen X. (2018). Analysis of Japan's Agricultural Mechanization Experience (日本农业机械化经验分析). *Modern Japanese Economy*, 37(2), 77–86. <https://doi.org/10.16123/j.cnki.issn.1000-355x.2018.02.007>
- [75] LÜ Q. (2013). *Research on Key Components and Prototype Design of the Ridge-Ploughing Tobacco Stalk Puller (垄垄刨掘式拔烟秆机关键部件研究与样机设计)*. Fujian Agriculture and Forestry University. <https://kns.cnki.net/KCMS/detail/detail.aspx?dbcode=CMFD&dbname=CMFD201601&filename=1016025266.nh>
- [76] Shu C. (2019). *Structural Optimization and Experimental Study of Key Components in Tobacco Stalk Breaker (烟秆拔秆破碎机关键部件结构优化及试验)* Guizhou University. <https://kns.cnki.net/KCMS/detail/detail.aspx?dbcode=CMFD&dbname=CMFD201902&filename=1019846195.nh>

- [77] Yorifuji, T., Tanihara, S., Takao, S., & Kawachi, I. (2011). Regional disparities in compliance with tobacco control policy in Japan: An ecological analysis. *Tobacco Control*, 20(5), 374–379. <https://doi.org/10.1136/tc.2010.041442>
- [78] Zhang X., Tong Z., Li L., Li Y., Hou Z., & Xia Y. (2018). Design and Experimental Study of a Compound Cutting Tobacco Cultivator with Soil Cultivation Function (复合切削式烟草中耕培土机设计与试验). *Journal of Agricultural Machinery*, 49(9), 73–81. China
- [79] Pan T., Wu S., He D., Dai E., & Liu Y. (2012). The Role of Vertical Ridge and Valley Topography in the Southwest Region of China in Regional Ecological Geography Patterns (中国西南地区纵向岭谷地形对区域生态地理格局的作用). *Journal of Geographical Sciences*, 22(5), 825–842. China
- [80] Wang Z., Wu C., Zhang F., Li Z., & Wang D. (2021). Current Research Status and Recommendations on Mechanization of Tobacco Production in Mountainous and Hilly Regions (山地丘陵烟草机械化研究现状及建议). *Agricultural Engineering*, 11(12), 20–25. China
- [81] Fisher, L. (2000). Tobacco farming and tobacco control in the United States. *Cancer Causes & Control*, 11(10), 977–979. <https://doi.org/10.1023/A:1026756331165>