

DESIGN AND EXPERIMENT OF A CIRCULAR GUIDE RAIL TYPE PRECISION PICKUP AND DELIVERY DEVICE FOR VEGETABLE PLUG SEEDLINGS

环形导轨式蔬菜穴盘苗精准取投装置设计与试验

Kaiyan XIN, Xinyu BIAN, Yuecheng WU, Shuai GAO, Ping ZHAO*, Subo TIAN*¹

College of Engineering, Shenyang Agricultural University, Shenyang 110161, China

Co-corresponding author: Ping Zhao, Subo Tian

Ping Zhao Tel: 13591675814; E-mail: zhaopingxdg@syau.edu.cn;

Subo Tian Tel: 13940428180; E-mail: tiansubo@syau.edu.cn;

DOI: <https://doi.org/10.35633/inmateh-78-100>

Keywords: Circular guide rail; Plug seedling; Pick-and-place device; Response surface methodology; PLC control; Vegetable transplanter

ABSTRACT

To address the low efficiency and high labor intensity of manual seedling feeding in semi-automatic transplanters, this study designed a novel circular guide rail type automatic pick-and-place device for the 2ZB-2B transplanter. This novel mechanism adopts a circular guide rail to achieve whole-row seedling picking and ring-distributed planting, solving the problems of structural complexity and low efficiency in existing devices. Through single-factor and response surface methodology optimization, the optimal operating parameters were determined. Under these conditions, the pick-and-place success rate reached 92.29%, and the field transplanting success rate achieved 90.28%, meeting operational requirements. This design provides a practical foundation for the development of fully automatic transplanters.

摘要

针对半自动移栽机人工喂苗效率低、劳动强度大的问题，本研究为 2ZB-2B 型移栽机设计了一种新型环形导轨式自动取投苗装置。该新型机构采用环形导轨实现整排取苗与环形投苗，解决了现有装置结构复杂、作业效率偏低的问题。通过单因素试验与响应面法优化，确定了最优作业参数；在此条件下，装置取投苗成功率达 92.29%，田间移栽成活率达 90.28%，满足作业要求。该设计为全自动移栽机的研制提供了实践基础。

INTRODUCTION

China is the world's largest vegetable producer, accounting for approximately 50% of global vegetable output (FAO, 2020; Wang et al., 2020; Tang et al., 2023). In recent years, both the cultivation area and yield of vegetables in China have continued to rise, reaching 22,873.46 thousand hectares and 82,868.11 million tons, respectively, in 2023. Transplanted cultivation constitutes about one-quarter of the total vegetable planting area in China and represents a key direction for the future of national agricultural production (Yang et al., 2018). Plug seedling cultivation, characterized by high emergence uniformity, consistent seedling quality, and improved transplant survival rates (Ma et al., 2020; Dias & Ryder, 2011), has become the predominant method for vegetable seedling production in China (Dang et al., 2019; Wang et al., 2016). Its efficiency and quality directly influence the economic returns and developmental potential of the vegetable industry.

Vegetable transplanting is performed mainly through two methods: traditional manual transplanting and mechanical transplanting (Wen et al., 2021). Manual operations are labor-intensive, inefficient, increasingly costly, and struggle to ensure consistent transplanting quality (Khedekar A., Mathur S.M., & Gaikwad B.B., 2018; Kumar G.P., & Raheman H., 2011). In contrast, mechanical transplanting offers an effective approach to reduce labor intensity while enhancing operational efficiency and stability (Cheng et al., 2024). Currently, transplanter development is evolving from semi-automatic towards fully automatic systems (Pérez-Ruiz & Slaughter, 2021). However, the working efficiency of semi-automatic transplanters is increasingly inadequate to meet the growing demands of vegetable production, making the advancement of fully automatic transplanting technology an inevitable trend (Yang et al., 2018; Mao et al., 2014; Rahul et al., 2019).

¹ Kaiyan Xin, M.S. Agr.; Ping Zhao, Prof. Ph.D. Eng.; Subo Tian, Prof. Ph.D. Eng.

Various automated transplanting solutions have been developed worldwide. The Futura five-row automatic transplanter manufactured by Ferrari Costruzioni Meccaniche (Italy) features a large structural configuration suitable for multi-row operations with wide row spacing (Shi *et al.*, 2024). In contrast, due to regional constraints in Japan, transplanting machines are typically designed to be compact and predominantly mechanical, with a limited level of automation and intelligent functionality (Yue *et al.*, 2022). The Australian Williams transplanter uses a pneumatically driven tray indexing system with PLC control for full automation, but its complex design leads to high maintenance costs. Kang *et al.* (2012) proposed a vegetable transplanting robot with a four-finger pneumatic gripping mechanism; however, its complexity increases stem damage risk. To address the insufficient pushing angle and impact-related issues associated with non-circular gear mechanisms, Zhou *et al.* (2023) proposed a helical gear–non-circular gear planetary transmission mechanism; however, its structural complexity indicates that further optimization of the pushing angle is still required. Liu *et al.* (2012) and Hu *et al.* (2012) applied duckbill and planetary five-bar mechanisms for tomato seedling transplanting, respectively. Li and Ma (2025) designed a double cam-link transmission using reverse motion law for cam profile optimization, but the structure requires high machining precision. Despite these efforts, challenges remain in agronomic adaptability, cost, structural complexity, and operational stability, with no widely adoptable practical model yet available. In particular, existing automatic pick-and-place mechanisms often require complex reciprocating motions or multiple actuators, leading to low efficiency and high failure rates. Therefore, this study designs a circular guide rail based automatic picking and planting device that enables continuous cyclic operation with a single row of claws, achieving whole-row gripping and ring-distributed planting. This device is specifically matched to the Ding Duo 2ZB-2B transplanter, providing a practical foundation for a fully automatic vegetable transplanter.

MATERIALS AND METHODS

Overall structure

The overall structure of the ring-guide automatic picking and planting device is shown in Fig. 1. It is specifically designed to match the square-arranged planting cups of the Ding Duo 2ZB-2B semi-automatic vegetable transplanter. The horizontal moving component is responsible for driving the connected ring picking and planting component to achieve precise back-and-forth movement between the tray picking position and the cup planting position. The ring picking and planting component features 12 picking and planting claws evenly distributed along the ring guide. These claws employ a double-finger four-needle design to grip and release the seedling plugs. The tray lifting component enables precise vertical movement of the tray to assist the picking claws in completing the seedling extraction action.

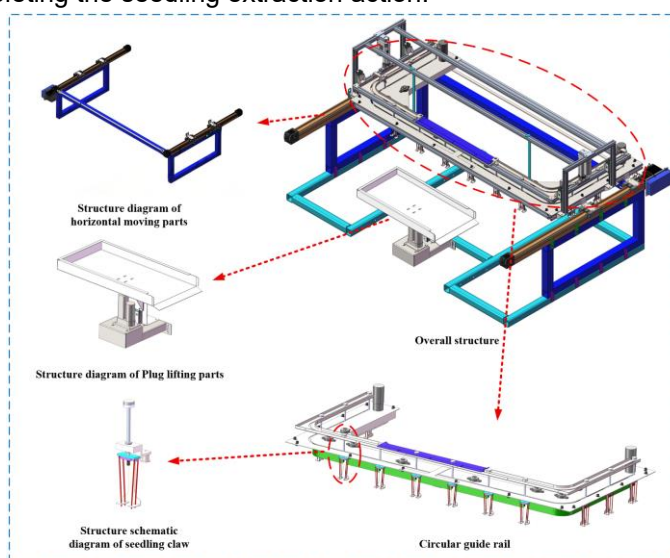

Fig. 1 – Schematic diagram of the complete machine structure

Working principle

Before starting operation, plug trays are placed on the tray holder of the tray lifting mechanism, all components are reset, and sensors detect their positions. The program stored in the Programmable Logic Controller (PLC) is executed for orderly operation, with each step proceeding continuously based on corresponding sensor detection. The working process consists of the following six steps: 1. The stepper motor

drives the horizontal component backward to the first row of the tray; 2. The electric cylinder extends, causing the claw needles to penetrate the seedling plug and grip it; 3. The tray lifting component retracts to extract the seedling plug; 4. The DC motor spreads the claw needles while the stepper motor moves the component forward to the cup position; 5. The electric cylinder retracts, the claw needles rise to release the seedling, and the seedling plug falls into the cup; 6. The DC motor closes the claw needles, the stepper motor moves the component backward to the next row, and the tray rises. After picking the last row, the tray is manually replaced, and the device resets to the first row to start again. The positioning accuracy of the horizontal and vertical movements is controlled by inductive sensors with a repeatability of ± 0.5 mm, which directly affects the seedling pick-up success rate. The gripping force and needle penetration depth determine the damage rate and extraction success. The cycle time per row (approximately 2.6 s) influences overall transplanting efficiency. The working principle is illustrated in Fig. 2.

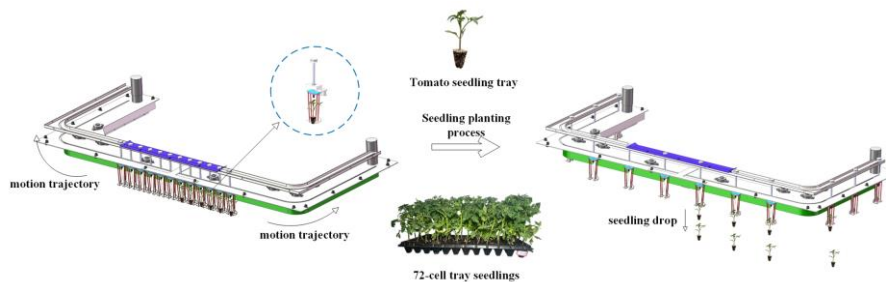

Fig. 2 – Schematic diagram of working principle

Design of key components. Circular guide rail design

The actual measurements of the relative positions of the planting cups of the Ding Duo 2ZB-2B transplanter and the picking positions of the plug tray were conducted for model plotting. The lower part consists of a 72-cell plug tray with a cell spacing of 42 mm, while the upper part features square-arranged planting cups with a spacing of 178 mm. At the turning points, the spacing between planting cups is 209 mm on the X-axis and 135 mm on the Y-axis. Z represents the distance from the center point of the planting cup to the required picking position, which increases synchronously as the number of picking actions increases, with an incremental distance of 42 mm. The R40 circular arc was selected as the most reasonable design for the ring guide, ensuring no interference while maintaining the success rate of picking and planting. The structural design of the circular guide rail is shown in Fig. 3.

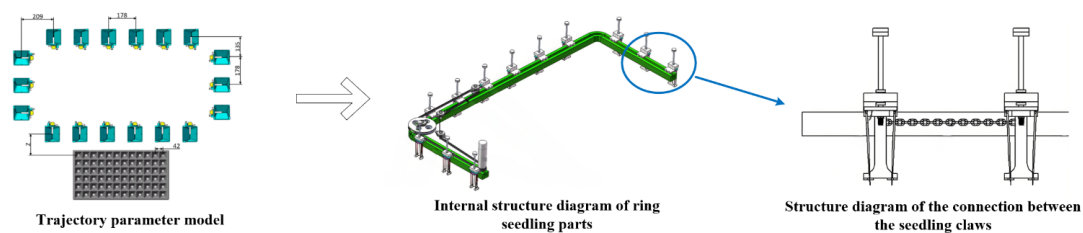

Fig. 3 – Circular Guide Rail Structural Design

Power requirement calculation for the ring drive (DC motor)

The ring picking and planting component uses a DC motor to drive the picking claws on the synchronous belt to perform spreading and closing actions. A 24V DC motor was selected as the driving force based on the available power source.

When the ring picking and planting component starts, it is under maximum load and must overcome the maximum friction. According to the operating mode of the synchronous belt driving the picking claws, calculating the maximum static friction yields:

$$F = fG \quad (1)$$

where: f static friction coefficient; G total weight to be carried under maximum load, N.

The picking claws and ring guide involve rolling friction. According to the Mechanical Design Handbook (5th Edition) and GB/T 13575.1-2022, the static friction coefficient between steel synchronous belt and aluminum alloy guide rail is taken as $f = 0.3$. The maximum weight of the picking claws and seedling plugs is 5 kg. The maximum static friction is:

$$F = fG = 0.3 \times 5 \times 10 = 15N \quad (2)$$

The picking claws move within the ring guide. The DC motor output power P is:

$$P = \frac{FV}{1000} \eta \quad (3)$$

where:

P maximum output power, kW;

V linear velocity of the picking claws, m/s;

F maximum static friction between picking claws and ring guide, N;

η mechanical efficiency of the synchronous belt.

The transmission form of the ring picking and planting component is a toothed synchronous belt. Consulting mechanical design manuals, the mechanical efficiency η of the synchronous belt is 0.98. Based on the calculated maximum static friction $F = 15$ N and the picking claw operating linear velocity of 0.45 m/s, the maximum power required for the ring picking and planting component is:

$$P = \frac{FV}{1000} \eta = \frac{15 \times 0.45}{1000} \times 0.98 = 0.006615kW \quad (4)$$

Based on the calculated theoretical motor power, a DC motor with a rated power P of 50 W should be selected.

To validate the motor selection, no-load and rated load tests were conducted. The 50 W DC motor operated stably under the maximum design load, with temperature rise and speed fluctuation meeting the design requirements. Thus, the motor selection is verified to be reliable.

Picking claw mechanical analysis

The claw needle form used for the picking claw is an inverted U-shape, with its structure and dimensions shown in Fig. 6. Based on the previous plug seedling substrate extraction force test, the maximum extraction force was 7.582 N. F_z is the total longitudinal extraction force of the picking claw, and F is the measured maximum extraction force.

The total longitudinal extraction force F_z of the picking claw can be derived as:

$$F_z = \frac{4F}{\cos \alpha} (\mu \cos \alpha + \sin \alpha) = 4F(\mu + \tan \alpha) = 20.57N \quad (5)$$

where:

F measured maximum extraction force, taken as 7.582 N;

α claw needle angle, taken as 8° ;

μ friction coefficient between claw needle and substrate, taken as 0.7.

The actual driving force relationship is:

$$P \geq F_z \frac{K_1 K_2}{\eta} \quad (6)$$

where:

η working efficiency, looked up from tables, taken as 0.9;

K_1 working condition coefficient, taken as 1.1.

When the maximum acceleration during picking claw gripping is $\mu_\alpha = g$, then:

$$K_2 = 1 + \frac{a}{g} = 2 \quad (7)$$

Substituting data into Equation (6) yields $P \approx 50.29$ N.

The claw needle of the picking claw is driven by an electric cylinder. The calculation shows the driving force on the picking claw is 12.5 N, and the force acting on a single claw needle is 6.25 N. Through physical property parameter tests, the maximum force experienced by a claw needle penetrating the substrate was measured as 1.994 N. After calculation, the force acting on the claw needle is 3.988 N. As shown in Fig. 4, which illustrates the claw needle boundary condition settings:

A fixed support constraint is applied at the bending section of the claw needle.

A vertical downward penetration force of 3.988 N is applied at the tip of the claw needle.

The material is set to 304 stainless steel, with elastic-plastic properties defined.

The contact between claw needle and seedling substrate is set as frictional contact ($\mu = 0.7$).

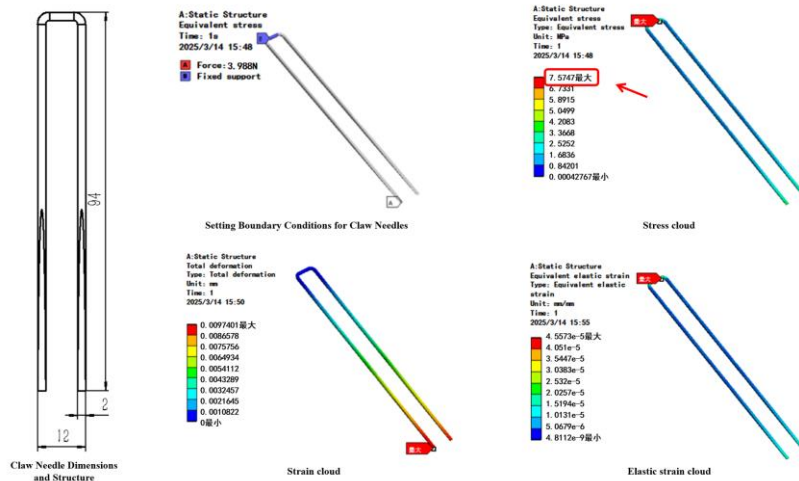

Fig. 4 – Claw Needle Dimensions, Structure, and Simulation Analysis

As shown in Fig. 4, the maximum stress on the claw needle is concentrated at the bend of the picking claw needle, approximately 7.57 MPa. The stress is less than the yield strength of stainless steel material (235 MPa). The maximum displacement is 0.009 mm, and the maximum elastic strain is 4.5573×10^{-5} mm, meeting the design requirements.

Sensitivity analysis of key design parameters

To evaluate the robustness of the motor selection and mechanical design, a one-at-a-time sensitivity analysis was performed on the friction coefficient and extraction force. The nominal friction coefficient $f = 0.3$ was varied between 0.2 and 0.4, covering the reasonable range for steel-plastic contact. The required motor power recalculated using Eq. (4) increased from 0.0044 kW to 0.0088 kW, which is still two orders of magnitude lower than the selected 50 W motor rating (safety factor > 5.6). The measured maximum extraction force (7.582 N) was varied by $\pm 20\%$ (6.07–9.10 N), and the corresponding claw needle stress changed from 6.06 MPa to 9.08 MPa, all well below the yield strength of stainless steel (235 MPa). In addition, the response surface analysis shows that within the recommended operating ranges (moisture 44–55 %, speed 0.45–0.67 m/s, age 35–43 days), the pick-and-place success rate remains above 88 %, confirming that the device tolerates typical field variations. These results demonstrate the robustness of the design against uncertainties in the assumed parameters.

CONTROL SYSTEM DESIGN

The various moving parts of the proposed automatic picking and planting device are all driven by electricity as the power source. Its main electrical components consist of a programmable logic controller (PLC), sensors, electric push rods, a DC motor, and a stepper motor. This paper presents the control system schematic diagram of the automatic picking and planting device, as shown in Fig. 5. The signals output by the program stored in the programmable logic controller provide driving force to the electric push rods, stepper motor, and DC motor, thereby achieving normal automatic picking and planting operations.

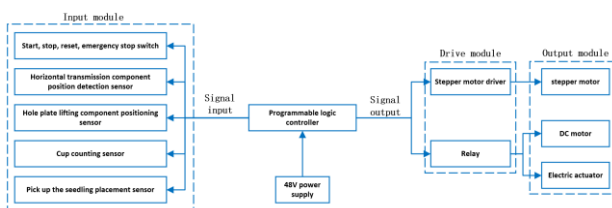

Fig. 5 – Control scheme diagram

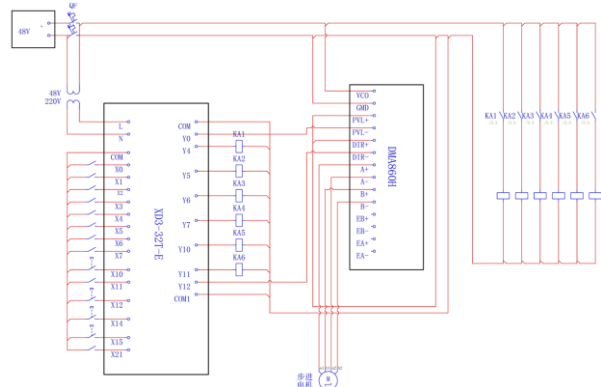

Fig. 6 – Control system circuit schematic diagram

The circuit schematic of the control system cooperated for the automatic pick-and-place device is shown in Fig. 6. It uses a Xinjian XD3-32T-E PLC as the control center, with sensors detecting and providing feedback on the positions of various components.

The complete control logic of the PLC program is presented in Fig. 7, covering system reset, seedling picking and planting, cycle counting, and manual tray replacement. The control system timing diagram (Fig. 8) quantitatively describes the sequential operation and coordination of each component in a single 2.5 s working cycle, ensuring stable and efficient operation of the device.

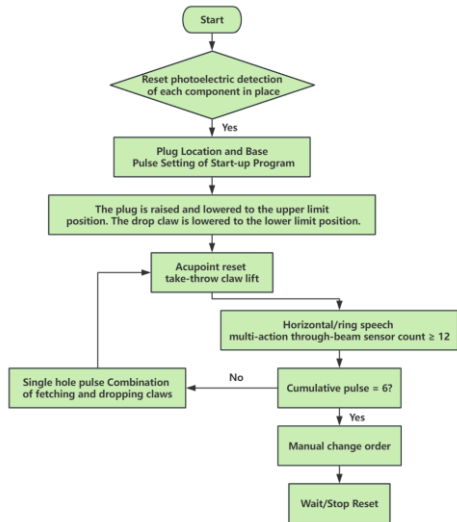

Fig. 7 – Flow chart of control logic

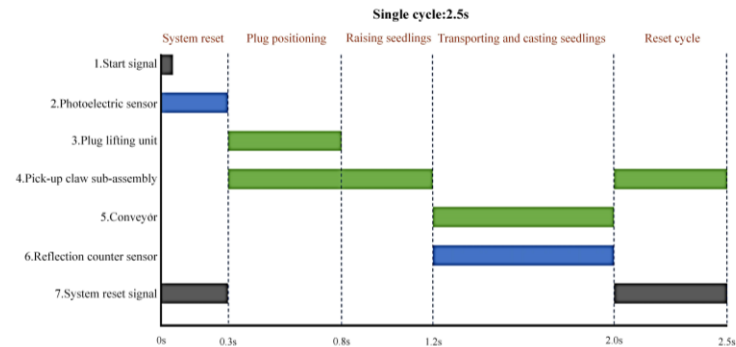

Fig. 8 – Control system timing diagram

Orderly control of collaboration between components through the PLC program allows the automatic pick-and-place device to perform grasping, transporting, and placing actions on the seedling plugs in the tray. The photoelectric sensors and position sensors were calibrated before the test to ensure the positioning accuracy and signal stability of each component.

OPTIMAL OPERATING CONDITIONS AND PERFORMANCE OPTIMIZATION

Single-factor experiments

The experimental site was a sunlight greenhouse at Liaoning Shuang Lin Agricultural Machinery Co., Ltd. The experimental prototype is shown in Fig. 9. The experimental field had clay soil. Before field experiments, the soil in the greenhouse was plowed and leveled to achieve a flat ridge surface after ridging, providing optimal operating conditions for the transplanter. The ridge top width was 800 mm, ridge height was 100 mm. This is illustrated in Fig. 10, soil absolute moisture content was 18.1%, environmental temperature was 16.2°C, and relative humidity was 48.0% RH.



Fig. 9 – Experimental prototype

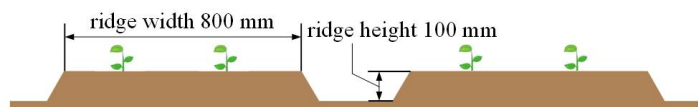

Fig. 10 – Plow furrow diagram

Based on a comprehensive analysis of the circular guide rail automatic pick-and-place device design, the substrate moisture content of the plug seedlings, transport speed, and seedling age were determined as experimental factors. The pick-up success rate (T_1), placement success rate (T_2), damage rate (T_3), and overall pick-and-place success rate (T) were used as experimental indicators, expressed by equations (8) to (11):

Pick-up success rate:

$$T_1 = \frac{N - N_1}{N} \times 100\% \tag{8}$$

Placement success rate:

$$T_2 = \frac{N - N_1 - N_2}{N - N_1} \times 100\% \tag{9}$$

Damage rate:

$$T_3 = \frac{N_3}{N - N_1} \times 100\% \tag{10}$$

Pick-and-place success rate:

$$T = \frac{N - N_1 - N_2 - N_3}{N} \times 100\% \tag{11}$$

where: N is the total number of seedlings; N_1 is the number of failed pick-ups;

N_2 is the number picked up but not successfully placed; N_3 is the number of damaged seedlings during pick-up (including stem/leaf damage and substrate breakage).

To investigate the influence of experimental factors on the performance of automatic transplanting of tomato plug seedlings, based on the determined factors and indicators, standardized cultivated tomato plug seedlings were selected as experimental materials for single-factor experiments. By analyzing the independent influence of each factor on the experimental indicators, the optimal operating ranges for each indicator were determined. Subsequently, a multi-factor orthogonal experimental design was used for parameter cooperate with optimization, ultimately obtaining the optimal combination of operating parameters for comprehensive system performance.

Based on substrate structural stability, substrate moisture content levels were set at 70%, 60%, 50%, 40%, and 30%. Based on operational efficiency and stability, transport speeds were set at 0.3 m/s, 0.45 m/s, 0.6 m/s, 0.75 m/s, and 0.9 m/s. Based on seedling growth stage and agronomic requirements, seedling ages were set at 30 d, 35 d, 40 d, 45 d, and 50 d. Through this single-factor experimental design, the influence of each factor on the pick-and-place success rate was systematically evaluated.

RESULTS AND ANALYSIS

As shown in Fig. 11a, the pick-and-place success rate increased from 78% at 70% moisture content to 92% at 50%, then decreased to 85% at 30%. The optimal range was 40–60%, with a peak near 50%. This is because low moisture content increases the adhesion between the substrate and the tray cell, making the plug difficult to extract; high moisture content reduces the friction between the claw needles and the substrate, also leading to difficulty in extracting the plug.

From Fig. 11b, the success rate was highest (91%) at a transport speed of 0.45 m/s, and decreased to 83% at 0.9 m/s. The decline is due to increased centrifugal force at the circular rail turns and higher impact forces during motor stops.

Fig. 11c shows that the success rate first increased from 84% (30 days) to 91% (40 days), then decreased to 86% (50 days). Younger seedlings have weaker root systems and smaller plugs, making extraction difficult; older seedlings have larger foliage that is easily damaged by the claws. The optimal seedling age range is 35–45 days.

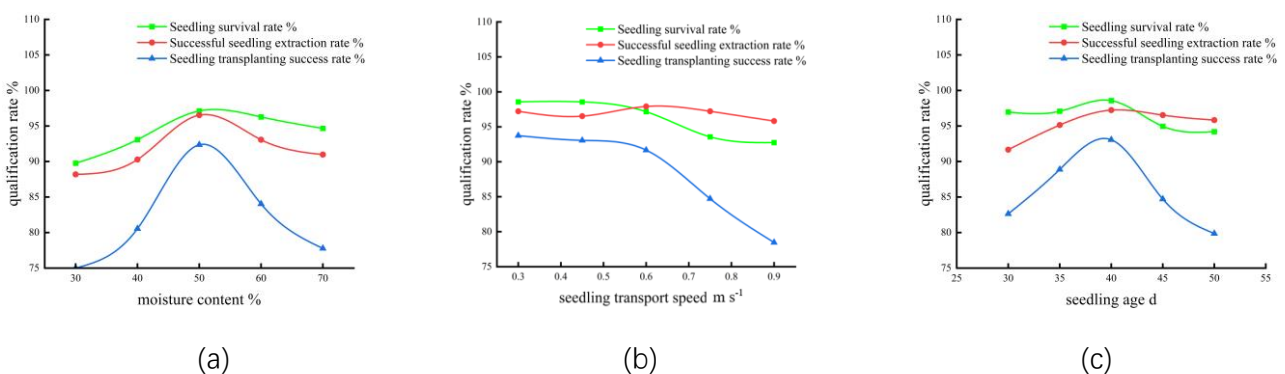

Fig. 11 – The influence of single factor on the test index:(a) Moisture content; (b) Seedling transport speed; (c) Seedling age

Older tomato plug seedlings had leaves and stems more susceptible to damage from the pick-and-place claws, affecting the success rate. Analysis revealed that seedling ages between 30 and 45 days were more suitable for transplanting with the automatic pick-and-place device. Older tomato plug seedlings had leaves and stems more susceptible to damage from the pick-and-place claws, affecting the success rate. Analysis revealed that seedling ages between 30 and 45 days were more suitable for transplanting with the automatic pick-and-place device.

ORTHOGONAL EXPERIMENT

Based on the single-factor experiment analysis of the influence patterns of substrate moisture content, transport speed, and seedling age on the experimental indicators, the optimal ranges for each indicator were determined. Subsequently, Design-Expert 13.0.1 software was used for experimental design, data processing, and analysis. The response surface methodology Central Composite Design (CCD) was chosen for the multi-factor experiment. The factor level coding table was calculated and is shown in Table 1.

Table 1

Coding of factor level

Coded value	Factor		
	X1 Moisture content of the substrate / %	X2 Seedling transportation speed / $m s^{-1}$	X3 The age of the seedlings in the tray / d
+1.682	60	0.75	45
+1	55.94	0.69	42.97
0	50	0.6	40
-1	44.05	0.51	37.02
-1.682	40	0.45	35

Table 2

Test results and schemes

test number	Moisture content of the substrate in the seedling clumps / X1 (%)	Seedling transportation speed X2 ($m s^{-1}$)	The age of the seedlings in the tray X3 (d)	The success rate of vaccine inoculation (%)
1	-1	-1	-1	90.11
2	1	-1	-1	79.89
3	-1	1	-1	83.34
4	1	1	-1	73.61
5	-1	-1	1	84.03
6	1	-1	1	75.69
7	-1	1	1	81.25
8	1	1	1	77.78
9	-1.68	0	0	84.72
10	1.68	0	0	74.00
11	0	-1.68	0	88.19
12	0	1.68	0	81.94
13	0	0	-1.68	84.72
14	0	0	1.68	82.64
15	0	0	0	92.36
16	0	0	0	90.97
17	0	0	0	93.06
18	0	0	0	91.67
19	0	0	0	93.75
20	0	0	0	91.67

Table 3

Analysis of variance					
Source	Quadratic sum	Degree of freedom	Mean square	F	P
model	787.41	9	87.49	52.63	<0.0001**
X ₁	181.52	1	181.52	109.2	<0.0001**
X ₂	43.06	1	43.06	25.91	0.0005**
X ₃	10.02	1	10.02	6.03	0.0340*
X ₁ X ₂	3.59	1	3.59	2.16	0.1724
X ₁ X ₃	8.28	1	8.28	4.98	0.0497*
X ₂ X ₃	19.1	1	19.1	11.49	0.0069**
X ₁ ²	339.51	1	339.51	204.24	<0.0001**
X ₂ ²	115.96	1	115.96	69.76	<0.0001**
X ₃ ²	159.46	1	159.46	95.92	<0.0001**
residual term	16.62	10	1.66		
lack of fit	11.39	5	2.28	2.18	0.2064
error term	5.23	5	1.05		
overall error	804.04	19			

EXPERIMENTAL RESULTS AND ANALYSIS

The experimental design and results are presented in Table 2. The ANOVA (Table 3) shows that the quadratic model is highly significant (F=52.63, P<0.0001), with a non-significant lack-of-fit (P=0.2064), indicating good model fit. The coefficient of determination R² was 0.979, and the adjusted R² was 0.961.

The F-values indicate that substrate moisture content (X₁, F=109.2) has the strongest effect on success rate, followed by transport speed (X₂, F=25.9) and seedling age (X₃, F=6.03). The quadratic terms X₁², X₂², X₃² are all highly significant (P<0.0001), confirming nonlinear responses. Among interactions, X₂X₃(speed×age) is significant (P=0.0069), while X₁X₂ is not (P=0.1724). The regression equation (after removing non-significant terms) is:

$$T = 92.29 - 3.65X_1 - 1.78X_2 - 0.8566X_3 + 1.02X_1X_3 + 1.55X_2X_3 - 4.85X_1^2 - 2.84X_2^2 - 3.33X_3^2$$

Six repeated center-point experiments (Nos. 15-20, at X₁=50%, X₂=0.6 m/s, X₃=40 d) yielded success rates of 92.36, 90.97, 93.06, 91.67, 93.75, and 91.67%, with a mean of 92.29% and a standard deviation of 1.02% (coefficient of variation 1.1%). This low variability confirms that the experimental procedure is repeatable and the device operates consistently. Using the regression model, the optimal parameters were: moisture content 47.39%, transport speed 0.56 m/s, seedling age 39.1 d, with a predicted success rate of 93.61%. Under these conditions, three validation experiments gave an average success rate of 92.15% (SD 0.87%), which is within 1.6% of the predicted value, confirming the model's accuracy.

The response surface plots (Fig. 12) visually confirm the interactions: the success rate increases with moderate moisture and speed, and decreases at extremes.

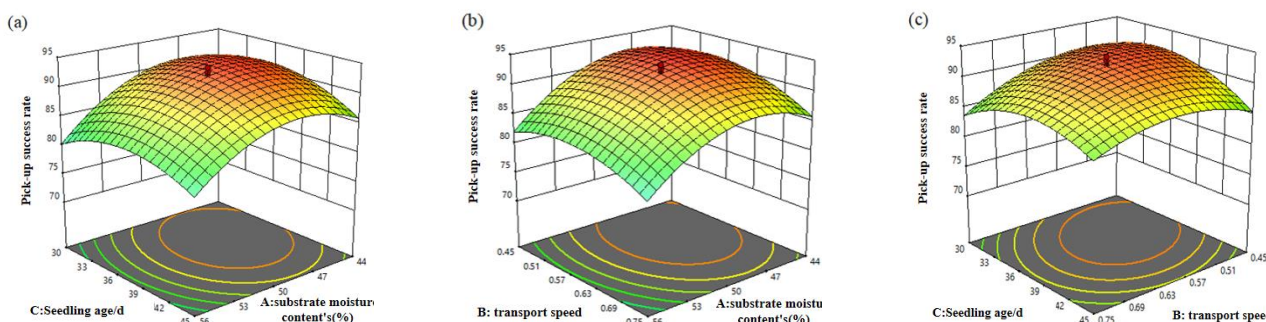

Fig. 12 – The influence of experimental factors on the success rate of taking and throwing seedlings

The response surface plots (Fig.12) illustrate the pairwise interaction effects on the pick-and-place success rate T. When transport speed is at the center level, T first increases then decreases with increasing seedling age and moisture content (Fig. 12a). When seedling age is at the center level, T shows a similar trend with moisture content and transport speed (Fig. 12b).

When moisture content is at the center level, T first increases then decreases with increasing seedling age and transport speed (Fig. 12c). Only the interaction between transport speed and moisture content (X_1X_2) was not significant ($P>0.05$), which is consistent with the ANOVA results.

FIELD TEST OF THE AUTOMATIC PICK-AND-PLACE DEVICE

To test the transplanting success rate under actual working conditions, field tests were conducted on the entire machine. Based on the performance tests above, the test location was a greenhouse at Liaoning Shuang Lin Agricultural Machinery Co., Ltd. The test subjects were three trays of 72-cell tomato seedlings. Seedlings aged about 39 days with a moisture content around 47% were selected for this test. The field test is shown in Fig. 13.



Fig. 13 – Field test

TEST RESULTS AND ANALYSIS

The test results are shown in Table 4:

Table 4

Statistical table of transplanting test results

serial number	Sum N / plant	Extract the number of failed plants N1 / plant	The number of plants removed but not put into use N2 / plant	Remove the number of damaged plants N3 / plant
1	72	4	2	0
2	72	3	3	1
3	72	3	2	1
mean value			91.20	90.28

Analysis of the data shows that during actual operation, issues such as seedlings getting caught on the cups due to overly dense foliage, and seedlings falling outside the cups after being picked due to machine shaking, occurred. These issues led to decreases in the pick-and-place success rate and transplanting success rate. Thus, the average transplanting success rate was 90.28%. This field performance test of the transplanter met the requirements of the national standard.

CONCLUSIONS

- (1) A compatible circular guide rail automatic pick-and-place device was designed for the Ding duo 2ZB-2B vegetable transplanter, achieving an operation mode of picking entire rows seedlings and placing them in a circular, dispersed manner.
- (2) The optimal operating parameters determined by single-factor and response surface methodology are: substrate moisture content 47%, transport speed 0.56 m/s, and seedling age 39 days. Under these conditions, the pick-and-place success rate reached 92.29%, and the field transplanting success rate was 90.28%, meeting agricultural requirements.
- (3) The device is currently limited to 72-cell trays and tomato seedlings. Performance may vary with other crops or tray geometries. Manual tray replacement and sensitivity to moisture content (the most influential factor, $F=109.2$) also constrain continuous operation.
- (4) Main technical challenges encountered include foliage entanglement with claws, vibration-induced misalignment at speeds >0.75 m/s, and sensor drift requiring weekly recalibration. These were partially mitigated by adjusting gripping force, reducing speed, and regular calibration.
- (5) Future work will focus on: automatic tray feeding; real-time moisture feedback control; testing on other seedlings and tray sizes; and vibration damping with active alignment for high-speed stability.

ACKNOWLEDGEMENTS

Our appreciation also goes to Ding Duo Co., Ltd. for providing workshop space and technical guidance for equipment fabrication and installation, as well as to Shuang Lin Agricultural Machinery Co., Ltd. for supporting the field tests with their experimental site.

REFERENCES

- [1] An, H.Y., Liu, W., Sun, G.Q., Sheng, S., Xie, J., Miao, Q.S., & Zhang, J.K. (2019). Application of full-automatic vegetable transplanter in production (全自动蔬菜移栽机在生产中的应用). *Agricultural Engineering*, Vol. 9, pp. 15-17, Beijing/China.
- [2] Cheng, B., Wu, H.R., Zhu, H.J., Liang, J., Miao, Y.S., Cui, Y.L., & Song, W.T. (2024). Current status and analysis of key technologies in automatic transplanters for vegetables in China. *Agriculture*, Vol. 14, 2168, Switzerland. <https://doi.org/10.3390/agriculture14122168>
- [3] Dang, Y.G., Jin, X., Li, H.J., Wang, J., Lu, Y.B., Ding, B.W., & Li, X. (2019). Design of 4-bar linkage seedling picking and planting manipulator with single degree of freedom (单自由度四连杆取投苗机械臂设计). *Transactions of the Chinese Society of Agricultural Engineering*, Vol. 35, pp. 39-47, Beijing/China.
- [4] Dias, J.S., & Ryder, E.J. (2011). World vegetable industry: production, breeding, trends. *Horticultural Reviews*, Vol. 38, pp. 299-356, United States.
- [5] FAO (Food and Agriculture Organization of the United Nations), (2020). *FAO Statistical Yearbook 2020: World Food and Agriculture*. Retrieved from <http://faostat.fao.org>.
- [6] Hu, F., Guo, D., Chen, C.R., Yan, H., Yin, W.Q., & Yu, H.M. (2021). Design and experiment of double-row planting device on plastic film for vegetables based on compound crank-rocker mechanism (复合曲柄摇杆式蔬菜膜上双行栽植装置设计与试验). *Transactions of the Chinese Society for Agricultural Machinery*, Vol. 52, pp. 62-69, Beijing/China.
- [7] Kang, D.H., Kim, D.E., Lee, G.I., Kim, Y.H., Lee, H.J., & Min, Y.B. (2012). Development of a vegetable transplanting robot. *Journal of Biosystems Engineering*, Vol. 37, pp. 201-208, South Korea.
- [8] Khadatkar, A., Mathur, S.M., & Gaikwad, B.B. (2018). Automation in transplanting: a smart way of vegetable cultivation. *Current Science*, Vol. 115, pp. 1884-1892, India. <https://doi.org/10.18520/cs.v115.i10.1884-1892>
- [9] Kumar, G.V.P., & Raheman, H. (2011). Development of a walk-behind type hand tractor powered vegetable transplanter for paper pot seedlings. *Biosystems Engineering*, Vol. 110, pp. 189-197, Netherlands. <https://doi.org/10.1016/j.biosystemseng.2011.08.001>
- [10] Li, H.S., & Ma, J.F. (2025). Research on cam-type seedling picking and planting transmission mechanism of vegetable transplanter based on reverse motion law (基于反转运动规律的蔬菜移栽机凸轮取投苗传动机构研究). *Transactions of the Chinese Society for Agricultural Machinery*, Vol. 56, pp. 223-233+263, Beijing/China.
- [11] Liu, J.D., Cao, W.B., Tian, D.Y., & Zhao, H.Z. (2017). Kinematics analysis and experiment of effective zero-speed planting mechanism for plug seedlings (钵苗有效零速移栽栽植机构运动学分析与试验). *Journal of Mechanical Engineering*, Vol. 53, pp. 76-84, Beijing/China.
- [12] Ma, G.X., Mao, H.P., Bu, Q., Han, L.H., Shabbir, A., & Gao, F. (2020). Effect of compound biochar substrate on the root growth of cucumber plug seedlings. *Agronomy*, Vol. 10, 1080, Switzerland. <https://doi.org/10.3390/agronomy10081080>
- [13] Mao, H.P., Han, L.H., Hu, J.P., & Kumi, F. (2014). Development of a pincette-type pick-up device for automatic transplanting of greenhouse seedlings. *Applied Engineering in Agriculture*, Vol. 30, pp. 547-556, United States. <https://doi.org/10.13031/aea.30.10550>
- [14] Pérez-Ruiz, M., & Slaughter, D.C. (2021). Development of a precision 3-row synchronised transplanter. *Biosystems Engineering*, Vol. 206, pp. 67-78, Netherlands. <https://doi.org/10.1016/j.biosystemseng.2021.03.014>
- [15] Rahul, K., Raheman, H., & Paradkar, V. (2019). Design and development of a 5R 2DOF parallel robot arm for handling paper pot seedlings in a vegetable transplanter. *Computers and Electronics in Agriculture*, Vol. 166, 105014, Netherlands. <https://doi.org/10.1016/j.compag.2019.105014>

- [16] Shi, J.W., Hu, J.P., Li, J., Liu, W., Yue, R.C., Zhang, T.F., & Yao, M.J. (2024). Design and experiment of planting mechanism of automatic transplanter for densely planted vegetables. *Agriculture*, Vol. 14, 1357, Switzerland. <https://doi.org/10.3390/agriculture14081357>
- [17] Tang, Y., Dong, J.L., Gruda, N., & Jiang, H.B. (2023). China requires a sustainable transition of vegetable supply from area-dependent to yield-dependent and decreased vegetable loss and waste. *International Journal of Environmental Research and Public Health*, Vol. 20, 1223, Switzerland. <https://doi.org/10.3390/ijerph20021223>
- [18] Wen, Y., Zhang, J., Yuan, T., & Tan, Y. (2021). Current situation and analysis of automatic pick-up technology for vegetable plug seedlings [J]. *Journal of China Agricultural University*, 26(4), 128-142.
- [19] Wang, X.Z., Dou, Z.X., Shi, X.J., Zou, C.Q., Liu, D.Y., Wang, Z.Y., & Chen, X.P. (2020). Innovative management programme reduces environmental impacts in Chinese vegetable production. *Nature Food*, Vol. 2, pp. 47-53, United Kingdom. <https://doi.org/10.1038/s43016-020-00199-0>
- [20] Yang, Q.Z., Xu, L., Shi, X.Y., Ibrar, A., Mao, H.P., Hu, J.P., & Han, L.H. (2018). Design of seedlings separation device with reciprocating movement seedling cups and its controlling system of the full-automatic plug seedling transplanter. *Computers and Electronics in Agriculture*, Vol. 147, pp. 131-145, Netherlands. <https://doi.org/10.1016/j.compag.2018.02.004>
- [21] Yue, R. C., Hu, J. P., Liu, Y. J., Yao, M. J., Zhang, T. F. & Shi, J. W. (2022). Design and working parameter optimization of pneumatic reciprocating seedling-picking device of automatic transplanter. *Agriculture*, Vol. 12, 1989, Switzerland. <https://doi.org/10.3390/agriculture12121989>.
- [22] Zhou, H.L., Liu, J.G., Yu, G.H., Qi, P., Wang, L., & Zheng, J. (2023). Research on seedling picking mechanism of helical-non-circular gear planetary train for vegetable transplanter (蔬菜移栽机斜齿轮 - 非圆齿轮行星轮系取苗机构研究). *Transactions of the Chinese Society for Agricultural Machinery*, Vol. 54, pp. 77-86, Beijing/China.