

DEVELOPMENT OF FOGPONICS CULTIVATION SYSTEM FOR MICROGREENS WITH INTERNET OF THINGS MONITORING SYSTEM AND MACHINE LEARNING AUTOMATION

PAGLINANG NG SISTEMA NG FOGPONICS PARA SA PAGTATANIM NG MGA MICROGREENS NA MAY SISTEMA NG PAGSUBAYBAY SA PAMAMAGITAN NG INTERNET OF THINGS AT AWTONASYON NG MACHINE LEARNING

Jamal Omar S. SARANGANI¹⁾, Carolyn Grace G. SOMERA-ALMEROL^{*2)}, Marvin M. CINENSE²⁾, Khavee Agustus W. BOTANGEN³⁾

¹⁾ Department of Agricultural and Biosystems Engineering, College of Engineering, Central Luzon State University, Science City of Muñoz, Nueva Ecija, Philippines

²⁾ Faculty of Department of Agricultural and Biosystems Engineering, College of Engineering, Central Luzon State University, Science City of Muñoz, Nueva Ecija, Philippines

³⁾ Faculty of Department of Information Technology, College of Engineering, Central Luzon State University, Science City of Muñoz, Nueva Ecija, Philippines

Corresponding Author: Carolyn Grace G. Somera-Almerol; E-mail: cggsomera@clsu.edu.ph

DOI: <https://doi.org/10.35633/inmateh-74-78>

Keywords: *Fogponics, Microgreens, Machine Learning, Internet of Things*

ABSTRACT

New technologies are emerging every day to improve the productivity of food production to meet rising demands. Microgreens have gained popularity nowadays and are known for being nutritious and easy to cultivate. Fogponics is one of the emerging technologies that atomizes the nutrient solutions into fine mist, improving the oxygenation and reduces water usage that lacks from traditional farming methods. The study developed an automated fogponics system for microgreens production using machine learning automation and internet of things monitoring systems. The model's evaluation output proves that the system is reliable and capable of predicting an appropriate direction given the datasets acquired from temperature and humidity while the plants are thriving over time. The system has successfully reduced the temperature fluctuation ranging from 26°-33°C to 27°-30°C and stabilized humidity levels from 75-100% to 90-96%. As a result, the performance of the model effectively yielded the microgreens to flourish in its environmental parameters by incorporating machine learning automation and IoT-based monitoring systems. This study strengthened the importance of contributing a promising alternative for sustainable microgreens production. This prototype represents its significant advancement in agricultural strategies for indoor microgreens cultivation, offering a potential alternative for efficient and scalable production.

ABSTRAK

Araw-araw may mga makabagong pamamaraan sa pagtatanim ang umuusbong upang mapabuti ang produksyon ng pagkain para matugunan ang tumataas na pangangailangan nito. Ang microgreens ay nagiging popular ngayon dahil sa taglay na sustansya at madaling paraan ng pagtatanim. Ang fogponics ay isa sa mga umuusbong na teknolohiya na mekanismong pagkontrol para sa awtomasyon ng nutrient solution sa pamamagitan ng usok, ito ay nakakatulong upang mapabuti sa oxygenation at mababang pagkonsumo ng tubig na kulangan sa mga tradisyunal na pamamaraan ng pagsasaka. Ang layunin ng pananaliksik na ito ay bumuo ng automated fogponics system para sa produksyon ng microgreens, gamit ang machine learning automation at internet of things monitoring systems. Ang resulta sa pagsusuri ng modelo ay napatunayan na ang sistema ay may kakayahan upang malaman ang angkop na direksyon batay sa mga datos na nakalap mula sa temperatura at halumigmig habang ang mga halaman ay simisibol. Ang sistema ay matagumpay na napanatili ang pagbabagu-bago ng temperatura mula 26°C-33°C naging 27°C-30°C at napanatili ang antas ng halumigmig mula 75%-100% naging 90%-96%. Bilang resulta, ang prototype ay epektibong nakapag-ani ng microgreens na yumabong sa pamamagitan ng pagsasama ng machine learning automation at IoT-based monitoring systems. Ang prototype na ito ay kumakatawan sa makabuluhang pag-aambag sa pag-unlad ng mga estratehiya sa agrikultura para sa indoor microgreens cultivation, may potensyal bilang alternatibong pamamaraan para sa mahusay at pangmalakihang produksyon.

INTRODUCTION

In 2017, the Food and Agriculture Organization (FAO) projected that the global population could reach 10 billion by 2050, representing a 34% increase from where it is now. Consequently, global food production must increase by 70% by 2050 to meet this demand. While population growth undeniably contributes to the rising demand for food, its impact is further intensified by shifts in consumption patterns. This connection between emerging food demands highlights the necessity for innovative approaches to agricultural production, particularly in addressing both the quantity and quality of the food supply. To address this growing need for more and better food, it is crucial to intensify and industrialize agricultural practices while also maximizing the efficiency of water and other resources.

Microgreens are gaining popularity nowadays due to their nutraceutical potential, ease of cultivation, year-round availability, and culinary versatility (*Jambor et al., 2022*). These young plants provide higher nutraceutical benefits than their mature counterparts due to their delicate texture, distinctive tastes, and excellent quantity of different nutrients (*Xiao et al., 2012*). Microgreens are cultivated and harvested before their true leaves emerge; they are usually harvested when they reach the height of 1 – 3 inches or between 5 – 21 days after germination. It should not be confused with sprouts and baby greens. Unlike sprouts, which are grown without light and harvested earlier, or baby greens, which are harvested between 20 – 40 days, microgreens offer unique advantages (*Partap et al., 2023*).

Various cultivation systems and growing media have been studied for microgreens farming, including soil and soilless cultivation systems and alternative growing medium (*Eswaranpillai et al., 2023; Gunjal et al., 2024*). Understanding of the most commonly used cultivation system for microgreen farming is gained from the work of *Paglialunga et al. (2023)*, who shed light on the significance of soil-less or hydroponics cultivation system. Although the hydroponics cultivation system has advantages in growing microgreens, it also has drawbacks such as mold and yeast development due to overexposure of seeds to the nutrient solution and inadequate air circulation (*Li et al., 2021; Ocho Bernal et al., 2023*). These issues can be mitigated by using an aeroponics cultivation system, which enhances oxygenation and water efficiency by spraying nutrient solutions directly onto the seeds or roots. It expedites the delivery of nutrients up to 135% for emitting droplets compared to the latter (*Eka Putri et al., 2023*).

On the other hand, a gentler nutrient delivery mechanism is imperative to cultivate microgreens to yield its optimal growth. The ultrasonic aeroponics or simply fogponics cultivation system manages these matters by atomizing the nutrient solution into a fine fog. It rests on the notion that the maximum particle capacity for a plant's nutrient absorption is between 1 – 25 micrometers in size (*Gandham et al., 2022*) whereas, this process fosters improved growth of the plants as it robust absorption of nutrients through its roots (*Gao et al., 2016; Lakhia et al., 2018*). Thereby, fogponics cultivation system was found to significantly minimizes consumption of water up to 50% (*Al-Kodmany, 2018*).

In spite of the existing advantages, various factors can affect the ability of the plant to thrive through its process (*Abbasi et al., 2024*). This method also poses challenges for the need to maintain adequate nutrient absorption and manage root zone temperature as well. Thus, appropriate management of nutrient solution and parameters such as light intensity, temperature, and humidity is essential for a successful cultivation especially when conducting the fogponics cultivation system (*Lakhia et al., 2018*).

Managing laborious tasks in agriculture is evident in the possibilities for enhancement made by integrating emerging technologies like machine learning-based automation and IoT monitoring systems. Furthermore, to yield the ideal growth of the plant, algorithms of machine learning optimize actuator settings. The work of *Ardiansah et al. (2023)* provides valuable insights into IoT monitoring systems, in which it facilitates real-time monitoring by overseeing its sensors, environmental conditions, and transmitting the data straight to the cloud. It also enables users to access the recorded readings of sensors through the application or the internet (*Ardiansah et al., 2022*). In the study of *Sarmphim et al. (2022)*, the researchers use Blynk application as an IoT for accessing sensor data and as an automation. Blynk application is an IoT platform that is user-friendly that can be access via smartphones.

This study aims to develop a prototype fogponics system design to establish productive indoor cultivation of microgreens by leveraging machine learning automation to optimize environmental conditions and resource usage, and IoT monitoring system to provide real-time data. Given the expressed significance to address the challenges encountered in traditional farming such as resource inefficiency and limited scalability, it is pertinent to explore such factors to contribute to a more sustainable and productive agricultural practices.

MATERIALS AND METHODS

In the development of automated fogponics system for microgreens, the researchers split the methodology into data gathering phase and training and validation phase. Data gathering phase is where the system is built and the data is collected for the training of the machine learning model. On the other hand, the training and validation phase is where the model is trained and subsequently the fogponics system is tested to assess the model's effectiveness.

Main setup

The automated fogponics system for microgreens consists of two containers namely nutrient tank and the growing box, along with a mainframe, LED lights, a power supply, and a control system (see Fig. 1). The nutrient tank, constructed from a plastic container, includes an ultrasonic fogger, blower fan, and water level sensor. It creates and transfers the atomized nutrient solution to the growing box. The growing box contains a seedling tray for holding seeds and the nutrient solution. The mainframe is built from PVC pipes and fittings. It supports the LED light, control system, and power supply. Meanwhile, the control system features a microcontroller that operates actuators and gathers sensor data, while the microprocessor interprets this data to predict actuator combinations; the Blynk application enables real-time monitoring, data logging, and machine learning model development.

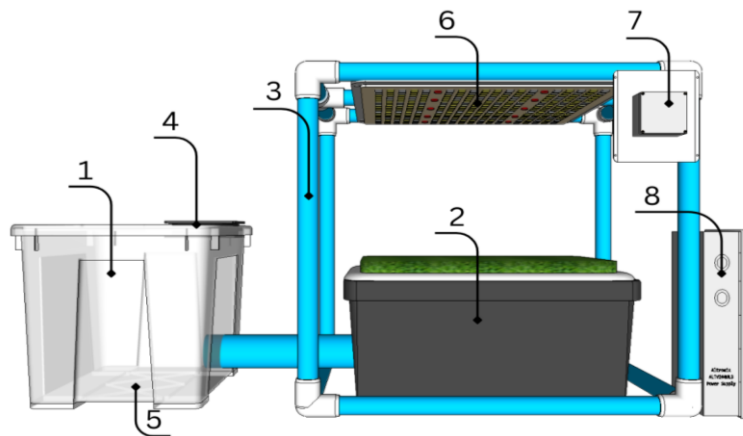

Fig. 1 - Fogponics system setup
 1 - nutrient tank, 2 - seedling box, 3 - main frame, 4 - fan, 5 - ultrasonic fogger,
 6 - LED light, 7 - control system, 8 - power supply

Circuit Diagram

Fig. 2 provides the comprehensive control and power circuit diagram of the study powered by ESP32 microcontroller. The ESP32 receives the data from the water level sensor, light sensor, and temperature and humidity sensor. The microcontroller ensures the interaction between various sensors and actuators. It uses a relay module to control the fogger and blower and uses PWM for adjusting the brightness of LED light. The buck converter provides needed voltages for the control system.

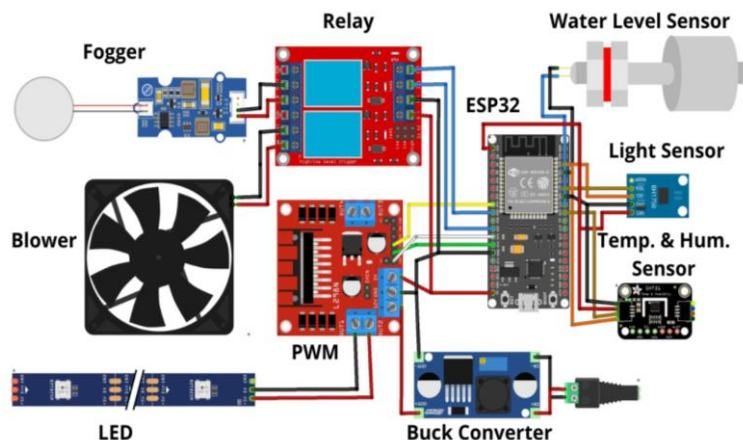

Fig. 2 - Control and power circuit diagram

Control System Diagram

In Fig.3A, the control system acquires data from actuators and sensors while the fogponics system operates, turning actuators on and off based on a researcher-set frequency.

A microcontroller, interfaced with various sensors and actuators, manipulates environmental conditions effectively. The Blynk application offers a user interface for monitoring, controlling the system, visualizing data, and logging data for machine learning model training.

Meanwhile, Fig.3B illustrates system automation, integrating both the microprocessor and microcontroller. The microcontroller, connected to sensors like temperature, humidity, light, and water level, gathers real-time data, relayed to the microprocessor for processing and decision-making. The microcontroller also controls actuators such as the blower, ultrasonic fogger, and LED lights. Additionally, the Blynk application provides a user interface for data visualization and manual system control.

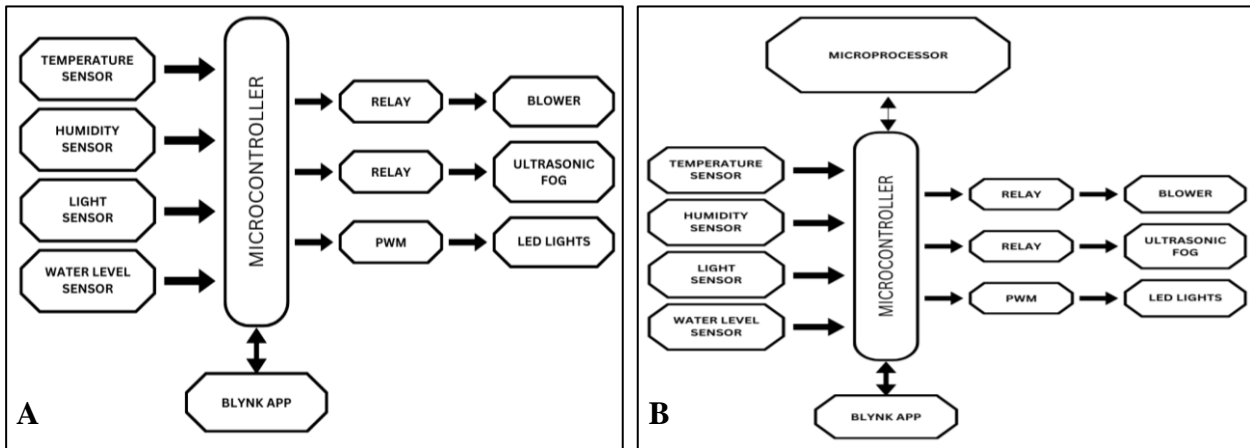

Fig. 3 - Control system diagram

System Flow Diagram

The Fig. 4A illustrates the phase 1 system flow diagram, starting with system initialization. The system includes the Blynk application which allows manual control of actuators, real-time data visualization, data logging, and simple automation. The microcontroller manages the actuator control and sensor data.

On the other hand, Fig. 4B depicts the phase 2 system flow diagram for automated fogponics systems, integrating both automated and manual controls. This phase is divided into microprocessor, microcontroller, and Blynk application subsystems. The process begins with component initialization. The microprocessor requests data from Blynk, processes it, and predicts necessary actions for the system. These actions are then communicated to the microcontroller, which controls the actuators and sensor reading. The application provides manual override capabilities, data visualization, and logging for real-time monitoring of system performance and environmental conditions.

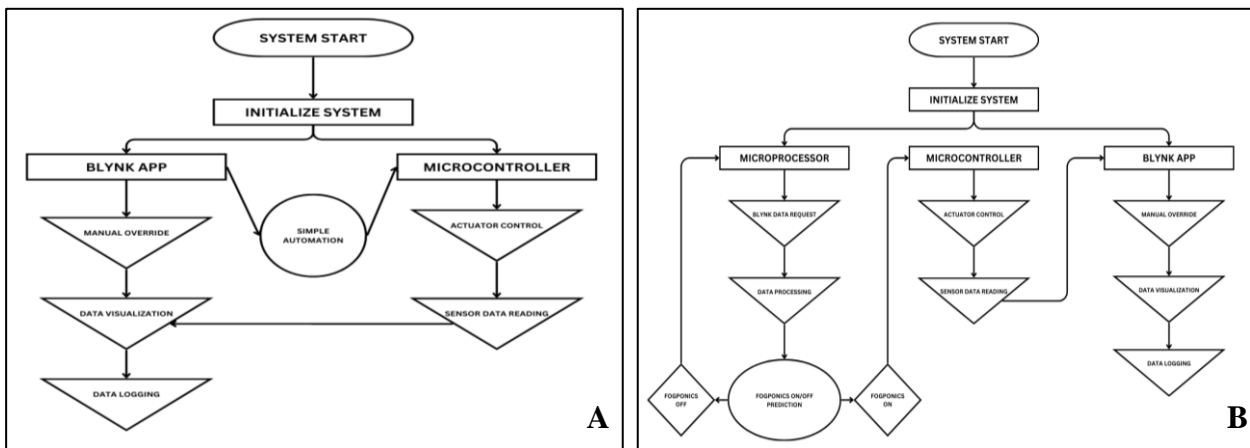

Fig. 4 - System flow diagram

Machine Learning Model

After gathering data in phase 1, it undergoes cleaning and processing using Python. K-means clustering algorithm is used to categorize environmental data and set controls for the fogponics system. Normalization is performed by subtracting the mean and dividing by the standard deviation of each feature, ensuring equal feature contribution to the clustering process. The model is then fitted with the normalized data, assigning each data point to one of two clusters: 1 for system "ON" or 0 for system "OFF." The processed data is saved to a CSV file for training the automation model.

The next step is the model training, where the random forest regression is used as a machine learning algorithm. During the training phase, it generates many decision trees. In order to measure a random subset of characteristics in each partition, a random subset of the data set is used to construct each tree. The combination of multiple decision trees makes it a stable and accurate prediction model.

Model Validation

The validation of accuracy and performance of the model is requisite to ensure the effectiveness of the model in predicting the values derived from the datasets. Thus, different methods are used to validate the model. Whereas, the data is split into 80% training data and 20% test data of the whole datasets. The training data is used to train the model while the test data is used to validate the model. The accuracy of the model is validated using metrics such as Precision, Recall, and F1-Score. On the other hand, the reliability of the model is validated using Root Mean Squared Error (RMSE) and R-squared (R^2).

Root Mean Squared Error (RMSE)

Prediction error metrics like Root Mean Squared Error (RSME), is the square root of MSE. It gives an approximation of the average variations between the predicted and actual results in the dataset.

$$RSME = \sqrt{\frac{1}{n} \sum_{i=1}^n (y_i - \hat{y}_i)^2} \quad (1)$$

where:

n denotes number of observation, y_i represents the actual value of i^{th} observation, and \hat{y}_i implies the predicted value of the i^{th} observation.

R-squared (R^2)

R-squared (R^2) measures how well the model explains how much variation of a dependent variable is explained by an independent variable in a regression model. Values closer to 1 means better model fit.

$$R^2 = 1 - \frac{RSS}{TSS} \quad (2)$$

where:

$R^2 = \text{coefficient of determination}$ denotes the coefficient of determination, RSS represent the sum of squares of residuals, and TSS stands for total sum of squares.

Precision

Accuracy metrics like Precision evaluate the accuracy of the ratio of true positive predictions to the total of predicted positives.

$$\text{Precision} = \frac{\text{True Positives}}{\text{True Positives} + \text{False Positives}} \quad (3)$$

Recall

Recall is measuring the model's ability to recognize the positive instances. It is solved as the ratio of true positive predictions to the total actual positives.

$$\text{Recall} = \frac{\text{True Positives}}{\text{True Positives} + \text{False Negatives}} \quad (4)$$

F1 Score

F1-Score on the other hand, is the harmonic mean of precision and recall. It is solved using this formula.

$$F1 \text{ Score} = 2 \times \frac{\text{Precision} \times \text{Recall}}{\text{Precision} + \text{Recall}} \quad (5)$$

RESULTS

Data Distribution

The Fig. 5A illustrates the data distribution of the state of temperature and humidity data during the data gathering phase of the study. Most of the temperature data clusters toward the middle range, with most values being around 28°C. The normal distribution of the temperature data is beneficial in training the machine learning model, this data helps the algorithm to process and learn the data efficiently. The baseline for predicting the average temperature conditions is due to the concentration of temperature at 28°C. While the humidity data is showing a heavily skewed distribution towards higher values. The data of humidity depicts values ranging from 75 to 100%, with 100% being the most frequent. This skewed distribution can influence the prediction accuracy of the model in humidity.

Consequently, Fig. 5B presents the distribution of temperature and humidity data when the machine learning model was applied to the system. The temperature histogram displays a more uniform distribution, with values ranging from 26.5°C to 30°C and a recurring value of 27.5°C. The temperature data reveals a steadier distribution, having a periodic value of 27.5°C. It shows the notable disparity in temperature compared to the initial data. Meanwhile, the humidity histogram shows a broader range from 84% to 98%, with the most frequent value around 94%. The humidity graph has shown a significant change in the distribution of data. The humidity data is showing a much stable distribution, with values ranging from 84% to 98%.

The shown data indicates the effectiveness of implementation of machine learning models in the system. In addition, the system has successfully reduced the frequency of extreme values of environmental factors, effectively regulated the environmental conditions within the favorable range that contributes to plant growth.

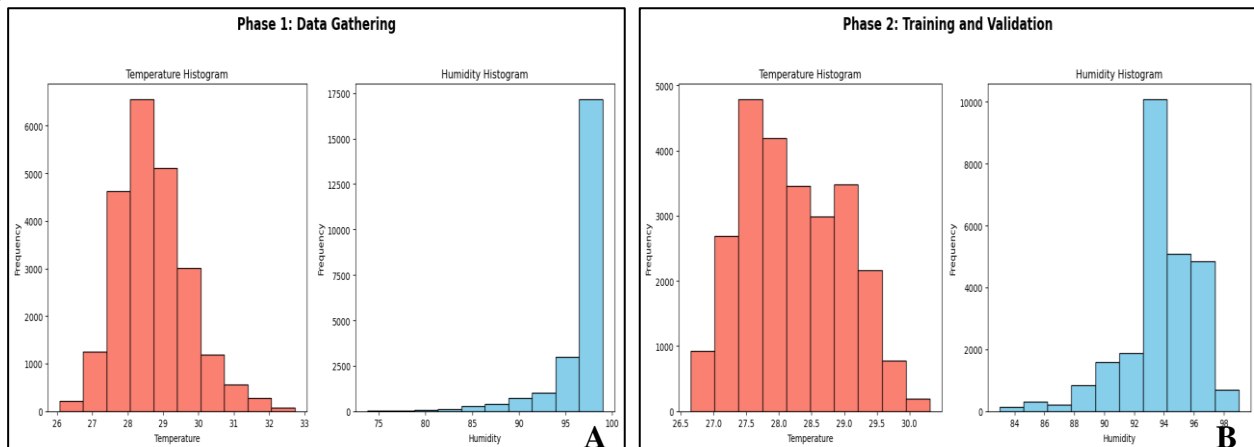

Fig. 5 - Temperature and Humidity histogram

Data Over Time

The graph depicted in Fig. 6 shows the data log from the Blynk application before implementing the machine learning model. The first graph illustrates the temperature variations over time, showing fluctuations of highs and lows. The temperature values are ranging from 26°C to 33°C in general. Thus, there is a notable rise in temperature as time progresses, suggesting a warming trend over the observed period.

On the other hand, the second graph illustrates the humidity levels over time. In the first part, the humidity stays close to 100% but it suddenly drops around 75%. After this, it demonstrates a more variability in values that range around 75% to 100%.

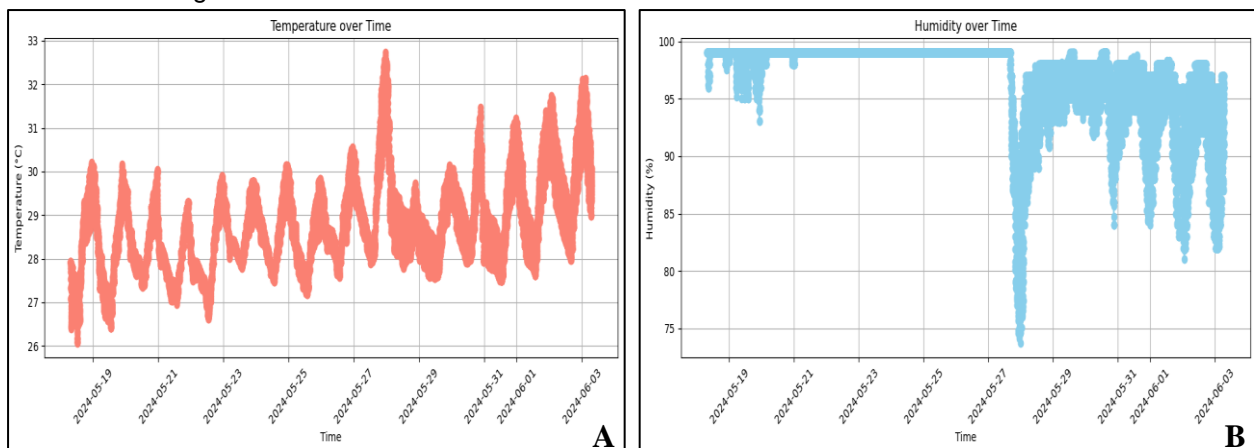

Fig. 6 - Phase 1: Temperature and Humidity over time data

The graph illustrated in Fig. 7 shows the data log of using machine learning in the fogponics system. The temperature graph shows that the fluctuation of temperature is between 27°C to 30°C. The graph also suggests that temperature peaks consistently around midday, while declining during the night. There is also a slight downward shift of temperature at the end of the period. Alternatively, the graph of humidity over time period remains relatively in the range of 90% to 96%, with a slight variation in the early part of the graph ranging from 84% to 98%.

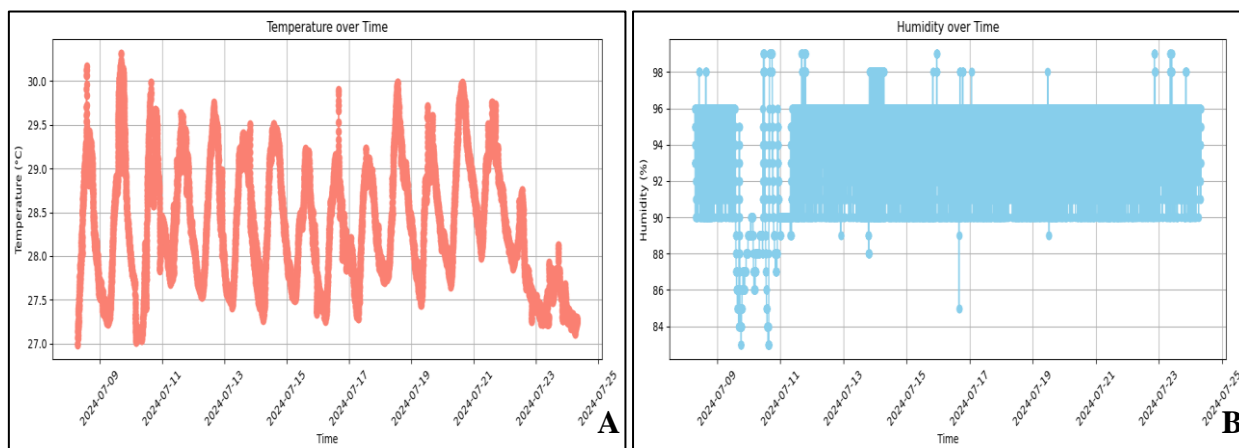

Fig. 7 - Phase 2: Temperature and Humidity over time data

The performance of the fogponics system with machine learning automation is assessed by comparing the temperature and humidity before and during the implementation of the machine learning model. The temperature fluctuation has decreased from 26°C to 33°C. The temperature is more consistent and exhibits a more stable pattern.

Meanwhile, this indicates the model’s effectiveness in regulating the environmental conditions. This wider range, seen in first phase, suggests that the machine learning model is actively controlling the humidity levels more dynamically, making sure they stay within a range that is favorable for plant growth. The humidity had a significant change in fluctuation from values that range around 75%-100% respectively 90%-96%. Whereas, the humidity level is more consistent and less erratic. Plants need at least 90% relative humidity for it to be enough, but root zone temperature will be increased as atomization time increases which will result in abnormal plant growth. Thus, the improvement suggests that the implementation of the machine learning model was effective in upholding a more regulated and balanced environment.

Machine Learning Model Evaluation

Table 1

Result of machine learning model evaluation

Root Mean Squared Error	R-squared (R2)	Precision	Recall	F1 Score
0.0362	0.9884	0.9917	0.9983	0.9950

The table presents the performance evaluation of the random forest regression algorithms which is implemented in the study for automating the fogponics system. Through the combination of multiple decision trees, it establishes the model’s precise prediction. Thus, the metrics above provides an overview of the machine learning model performance.

For the first metric of machine learning model evaluation, which is Root Mean Squared Error (RMSE) that calculates the average deviation of predicted values from the actual values. An RMSE of 0.0362 suggests that, on average, the prediction of the model has a deviation of 0.0362. This implies the model’s capability to predict environmental parameters such as humidity and temperature with high accuracy. Following this is the R-squared (R2) where its value indicates how much variation of dependent variables is explained by an independent variable in the machine learning model. An 0.9884 R-squared value means 98.84% of the variance in the outcome can be explained by the model. It measures the model’s ratio of true positive predictions out of all positive predictions. An 0.9917 precision indicates that 99.17% of the positive predictions of the model were correct. The other metric is Recall. It assesses how the model can correctly identify the true positive from all the actual positive data. A recall of 0.9983 implies that 99.83% of all actual positives are correctly identified. The final metric of machine learning model evaluation is the F1 Score, which indicates the balance ratio of precision and recall. An F1 score of 0.9950 means that the model’s overall performance is exceptionally good.

As has been demonstrated, the analysis of the result of machine learning model evaluation reveals that the model is highly effective in predicting the appropriate action of the fogponics system based on the temperature and humidity data. The high value of precision (0.9917), recall (0.9983), and F1 score (0.9950) reflects its reliability in making correct predictions. It further confirms by having low RMSE (0.0362) and high R-Squared value (0.9884) the significant predictive accuracy of the model.

Microgreen Growth Stage

The pictures shown in Fig. 8 illustrate the growth progression of microgreens before implementing the machine learning model. The growth of microgreen is somewhat uneven and less robust. The lack of uniform growth and the sparse density of the microgreens suggest that the environmental conditions are not optimal.



Fig. 8 - Phase 1: Gathering of training data

The pictures shown in Fig. 9 illustrate the growth of microgreens under the implementation of machine learning automation of the fogponics system. The microgreens are more uniform and appear healthier. This indicates that the environmental factors needed by the microgreens are met. The machine learning model is effective in producing microgreens in this kind of setup.



Fig. 9 - Phase 2: Machine Learning Implementation

Before and during the implementation of the machine learning model, it is shown that the microgreens have grown after 15 days of cultivation. In Fig. 8, although the microgreens have developed further, the growth is somewhat uneven. The uneven growth of plants may be due to the overwatering of the system. In contrast, in Fig. 9, the microgreens appear more uniform, denser and healthier. It indicates that the system has effectively cultivated microgreens indoors and significantly improved the control of the environmental parameters by incorporating machine learning automation and IoT-based monitoring systems.

Despite the fact that the machine learning model used in automating the fogponics system in this study is effective, further studies should be implemented to improve and assess the system's effectiveness. It is recommended to utilize image recognition to greatly enhance the capability of the system to recognize patterns and automate the system. In addition, implementing the system to a larger scale and different microgreens will evaluate the extent of the automated fogponics system.

CONCLUSIONS

The automated fogponics system for cultivating microgreens was developed to introduce potential alternatives for sustainable agricultural production. The use of the internet of things through Blynk application as a monitoring system has provided the ease of visualizing the different environmental parameters, and made the systems parts such as sensors and actuators interconnected. Whereas, the automation model of the system is trained using the random forest regression algorithm which maintains the parameters needed by microgreens to thrive. Based on the result of this study, using machine learning and internet of things in fogponics systems for microgreens production have been proven to be effective. The purpose of this study to develop an automated fogponics system for microgreens using machine learning automation and internet of things monitoring system has been accomplished. This study will introduce the potential alternative method of producing microgreens.

ACKNOWLEDGEMENT

The authors would like to express their gratitude to the Central Luzon State University - Engineering Research and Development for Technology (CLSU-ERDT) and the Department of Science and Technology – Science Education Institute (DOST-SEI) for providing financial support for the completion of this study.

REFERENCES

- [1] Abbasi, F., Khandan-Mirkohi, A., Ahmad, A. H., Kafi, M., & Shokrpour, M. (2024). Optimization of Aeroponic and Ultrasonic Soilless Culture Systems in Terms of Timing and Growth Characteristics of Liliun OT Hybrid. *International Journal of Horticultural Science and Technology*, 11(2), 269–284. <https://doi.org/10.22059/IJHST.2023.361423.658>
- [2] Al-Kodmany, K. (2018). The Vertical Farm: A Review of Developments and Implications for the Vertical City. *Buildings* 2018, 8(2), 24. <https://doi.org/10.3390/BUILDINGS8020024>
- [3] Ardiansah, I., Bafdal, N., Bono, A., Suryadi, E., & Nurhasanah, S. (2022). An Overview of IoT Based Intelligent Irrigation Systems For Greenhouse: Recent Trends And Challenges. *Journal of Applied Engineering Science*, 20(3), 657–672. <https://doi.org/10.5937/JAES0-35224>
- [4] Ardiansah, I., Calibra, R. G., Bafdal, N., Bono, A., Suryadi, E., & Nurhasanah, S. (2023). An IoT-Enabled Design for Real-Time Water Quality Monitoring and Control of Greenhouse Irrigation Systems. *INMATEH - Agricultural Engineering*, 68(3), 417–426. <https://doi.org/10.35633/INMATEH-69-39>
- [5] Eka Putri, R., Fauzia, W. A., & Cherie, D. (2023). Monitoring and Control System Development on IoT-Based Aeroponic Growth of Pakcoy (*Brassica rapa* L.). *Jurnal Keteknikaan Pertanian*, 11(2), 222–239. <https://doi.org/10.19028/JTEP.011.2.222-239>
- [6] Eswaranpillai, U., Murugesan, P., & Karuppiyah, P. (2023). Assess the impact of cultivation substrates for growing sprouts and microgreens of selected four legumes and two grains and evaluation of its nutritional properties. *Plant Science Today*, 10(2), 160–169. <https://doi.org/10.14719/PST.2058>
- [7] FAO. (2017). *The future of food and agriculture and challenges*. Food and Agriculture Organization of the United Nations. <https://openknowledge.fao.org/server/api/core/bitstreams/2e90c833-8e84-46f2-a675-ea2d7afa4e24/content>
- [8] Gandham, V. V. S. K., Manohar, B. S. P. S., & Dhal, P. K. (2022). Esperanza-Expectation Leads to Inventions in Space. *International Journal of Recent Advances in Multidisciplinary Topics*, 3(3), 120–126. <https://journals.ijramt.com/index.php/ijramt/article/view/1883>
- [9] Gao, J., Zhang, J., & Lu, D. (2016). Design and Atomization Experiments of an Ultrasonic Atomizer with a Levitation Mechanism. *Applied Engineering in Agriculture*, 32(4), 353–360. <https://doi.org/10.13031/AEA.32.11029>
- [10] Gunjal, M., Singh, J., Kaur, J., Kaur, S., Nanda, V., Mehta, C. M., Bhadariya, V., & Rasane, P. (2024). Comparative analysis of morphological, nutritional, and bioactive properties of selected microgreens in alternative growing medium. *South African Journal of Botany*, 165, 188–201. <https://doi.org/10.1016/J.SAJB.2023.12.038>
- [11] Jambor, T., Knizatova, N., Valkova, V., Tirpak, F., Greifova, H., Kovacik, A., & Lukac, N. (2022). Microgreens as a functional component of the human diet: A review. *Journal of Microbiology, Biotechnology and Food Sciences*, 12(1), <https://doi.org/10.55251/JMBFS.5870>

- [12] Lakhiar, I. A., Gao, J., Syed, T. N., Chandio, F. A., & Buttar, N. A. (2018). Modern plant cultivation technologies in agriculture under controlled environment: a review on aeroponics. *Journal of Plant Interactions*, 13(1), 338–352. <https://doi.org/10.1080/17429145.2018.1472308>
- [13] Li, T., Lalk, G. T., & Bi, G. (2021). Fertilization and Pre-Sowing Seed Soaking Affect Yield and Mineral Nutrients of Ten Microgreen Species. *Horticulturae*, 7(2), 14. <https://doi.org/10.3390/HORTICULTURAE7020014>
- [14] Ocho Bernal, T. G., Lyttle, N., & Jung, Y. (2023). Microbiological quality of microgreen seeds purchased from online vendors and evaluating seed decontamination techniques available online. *Frontiers in Sustainable Food Systems*, 7, <https://doi.org/10.3389/fsufs.2023.1264472>
- [15] Paglialunga, G., El Nakhel, C., Proietti, S., Moscatello, S., Battistelli, A., Formisano, L., Ciriello, M., Del Bianco, M., De Pascale, S., & Roupael, Y. (2023). Substrate and fertigation management modulate microgreens production, quality and resource efficiency. *Frontiers in Sustainable Food Systems*, 7, <https://doi.org/10.3389/FSUFS.2023.1222914>
- [16] Partap, M., Sharma, D., HN, D., Thakur, M., Verma, V., Ujala, & Bhargava, B. (2023). Microgreen: A tiny plant with superfood potential. *Journal of Functional Foods*, 107, <https://doi.org/10.1016/J.JFF.2023.105697>
- [17] Sarmphim, P., Sutthiphon, N., Jaroensong, P., Sirisathitkul, C., & Sirisathitkul, Y. (2022). IoT Based soil moisture management using capacitive sensor and user-friendly smartphone application. *INMATEH - Agricultural Engineering*, 66(1), 159–166. <https://doi.org/10.35633/INMATEH-66-16>
- [18] Xiao, Z., Lester, G. E., Luo, Y., & Wang, Q. (2012). Assessment of vitamin and carotenoid concentrations of emerging food products: Edible microgreens. *Journal of Agricultural and Food Chemistry*, 60(31), 7644–7651. <https://doi.org/10.1021/jf300459b>