

SMART VENDING MACHINE, ENERGY INDEPENDENT, THERMALLY CONDITIONED, FOR PACKAGED AGRICULTURAL PRODUCTS

AUTOMAT DE VANZARE INTELIGENT, INDEPENDENT ENERGETIC, CONDITIONAT TERMIC, A PRODUSELOR AGRICOLE AMBALATE

Ioan Mihail SAVANIU, Oana TONCIU¹, Bogdan BEBESELEA¹,

Technical University of Civil Engineering Bucharest / Romania;

* E-mail: oana.tonciu@utcb.ro.ro

DOI: <https://doi.org/10.35633/inmateh-74-69>

Keywords: vending machine, energy independent, packaged agricultural products, mechatronics, energy-efficient farming.

ABSTRACT

In the context of the development of intelligent systems in the agricultural field, systems that help farmers in agricultural production, the realization of intelligent systems to help them in the commercialization of agricultural products is both actual and necessary. The commercialization of agricultural products directly by the farmer, at the farm gate, requires specially authorized spaces, personnel, connection to utilities, etc., which limits the possibilities for sale of products by farmers, thus losing both the final customer and the farmer, as the product enters the distribution chain, which implies an additional cost and uncertainties regarding the product origin. The article presents the SVIEE-R equipment, an automatic and autonomous system for selling agricultural products at the farm gate, which does not require the presence of a salesperson or connection to electricity and which can store agricultural products that require refrigeration, such as: vegetables, fruits, dairy products, etc. The intelligent SVIEE-R vending machine is a smart system that continuously informs both the farmer and the customer about the stock level of stored products, the storage temperature, and can be placed anywhere due to the energy independence provided by an array of photovoltaic panels and accumulators.

REZUMAT

In contextul dezvoltării sistemelor inteligente in domeniul agricol, sisteme care ii ajuta pe fermierii in partea de productie agricola, realizarea de sisteme inteligente, care sa ii ajute in partea de comercializare a produselor agricole, este actuala si necesara. Comercializarea produselor agricole direct de fermier, la poarta fermei, necesita spatii special amenajate autorizate, personal, racordare la utilităţii, etc, aspecte care limitează posibilităţile de comercializarea directa a produselor de către aceştia, astfel pierde atât clientul final cat si fermierul întrucât produsul intra in lanţul de distribuţie, ceea ce presupune un cost suplimentar si nesiguranţa in ceea ce priveşte originea produsului. Articolul prezinta echipamentul SVIEE-R care este un sistem automat si autonom de vânzare a produselor agricole, la poarta fermei, care nu necesita prezenta unui vânzător, racordare la energie electrica si care poate stoca produse agricole care necesita refrigerare cum ar fi: legume, fructe, produsele lactate, etc. Automatul inteligent SVIEE-R este un sistem inteligent care informează in permanenta atât fermierul si clientul in ceea ce priveşte stocul de produse depozitate, temperatura de păstrare si care poate fi amplasat oriunde datorita independentei energetice asigurata de o matrice de panouri fotovoltaice si acumulatori.

INTRODUCTION

In the context of the development of intelligent systems in the agricultural field, systems that help farmers in the agricultural production part, the realization of intelligent systems that help them in the marketing of agricultural products is current and necessary. Vendomats in agriculture are an innovative solution for selling agricultural products directly to consumers, eliminating middlemen and giving farmers more control over pricing and distribution. These vending machines can be used to sell a wide range of agricultural products such as: fresh or pasteurized milk, yoghurts, cheeses, butter; fresh eggs from chicken, duck or quail; fruits and vegetables, packaged in small quantities; fresh or processed meat in the case of vendomats equipped with freezing systems; fruit juices, some vendomats can prepare the juice on the spot from fresh fruit; honey, pollen,

¹ Ioan Mihail Savaniu, PhD. Eng., Associate professor; Oana Tonciu, PhD. Eng., Lecturer;
Bogdan Bebeselea, PhD. Student Eng.

propolis, phages; etc. Vendomates can help farmers by selling seeds (wheat, maize, vegetables) or fertilizers (granulated, liquid) in the vicinity of their plantations, depending on the season. Smart vending machines for farms or agricultural stores can commercialize animal fodder (grains, flours, granules) packaged in small or medium quantities. The advantages of using vendomats in agriculture are: availability 24 hours / 7 days, speed in purchasing products; farmers can sell products at the farm gate or place products at specialized fairs, intermediaries are eliminated and product prices decrease; personnel costs are reduced; the customer has the guarantee of the origin of the purchased product (**ZETOMAT, 2024). The use of vending machines equipped with refrigeration systems, similar to the SVIEE-R vending machine, is important for fresh agricultural products, these are perishable and require special storage conditions (controlled temperature, humidity, etc.). Smart vending machines, such as the one presented in the article, constantly communicate to the farmer the demand from customers, so he can either estimate the demand while reducing losses due to product expiration, or constantly provide products in order not to disappoint customers.

In the article “*Vending machines proving popular with producers*”, (2021), are presented solutions for farmers to market their products using vending machines with specialized boxes that are accessed through a software application. These vending machines are connected to the electricity grid and the internet and according to reports from farmers in the UK are used to market products such as eggs, chilled or frozen various agricultural products, dairy products, etc. The vending machines can provide information to the customer via an application about the stock of products and can reserve products.

The dispenser manufacturer Zuply in the article “*On-farm sales solutions*” (2024), offers vending machine solutions for agricultural products in the form of lockers or pusher machines. Vendomats the form of lockers or pusher machines have the possibility to refrigerate the products and are equipped with a touch screen through which the buyer can find various information about the products to be sold. For farmers in Romania, ZETOMAT (**ZETOMAT, 2024), offers various solutions for vending machines for agricultural products, solutions that significantly influence the profitability for farmers and bring multiple benefits for both producers and farmers.

The use of food vending machines in urban areas is increasing, as the authors of *Rombach et al, (2022)*, conclude. As the inhabitants of big cities appreciate fresh food directly from the producer, the vending machine market is growing. Farmers need to develop networks for selling agricultural products directly at the farm gate as well as vending machines for packaged products (*Sabău et al, 2023*).

In Germany, a system has been developed for farmers to sell different agricultural products by vending machines, called REGIOMAT (**Das Prinzip Regiomat, 2024). Thus, products such as fresh country milk, eggs, cheese, bread, honey, frozen products can be marketed in this system. Thus, regional products are marketed directly by the producer without intermediaries. The solutions presented above are vending machines that are connected to the public electricity grid and in some cases have to be installed in enclosed spaces to be protected from the outside environment.



Fig. 1 - Example of SVIEE-R vendomat placement in rural areas

The agricultural products vending machine SVIEE - R, presented in the article, is energy independent and realized in such a way that it can be placed in an open environment in any rural area, at the small farmer's door, as shown in Fig. 1, near a stable, near an orchard, near greenhouses, etc.

The SVIEE-R is equipped with a refrigeration system that allows the storage of agricultural products, products that require preservation at low temperatures. The automat allows the commercialization of the products through an application that transmits to the customer information about the products inside, photos of the products to be commercialized, their stock, their shelf life, their payment. The computerized system transmits information to the farmer about product stocks, indoor temperature, the amount of energy produced and stored in the accumulators, system errors, vandalism. The SVIEE-R system is designed as a closed box without glazed surfaces or screens to limit vandalism, as it can be placed in unpopulated areas. The closed enclosure construction ensures the storage of agricultural products in dark areas without exposure to solar radiation.

The validation of the use of the SVIEE-R vending system by farmers, a vending machine that can be placed anywhere in the rural environment without the need to be connected to the electricity grid, involved verifying the stability of the vending machine to wind action, ensuring the optimal temperature for storing agricultural products in the thermally conditioned enclosure, and the energy autonomy of the vending machine. The article presents the studies undertaken in order to establish the possibility of using the SVIEE-R vending system in rural areas by farmers in order to commercialize agricultural products at the farm gate.

MATERIALS AND METHODS

The SVIEE-R energy-independent agricultural product vending system developed within the POC 121420 project, shown in Fig. 2, is composed of the following systems: the power supply system using an array of three photovoltaic panels, the command-and-control system, the product cooling system, the thermally insulated enclosure for product storage, the product storage system, the product delivery system.

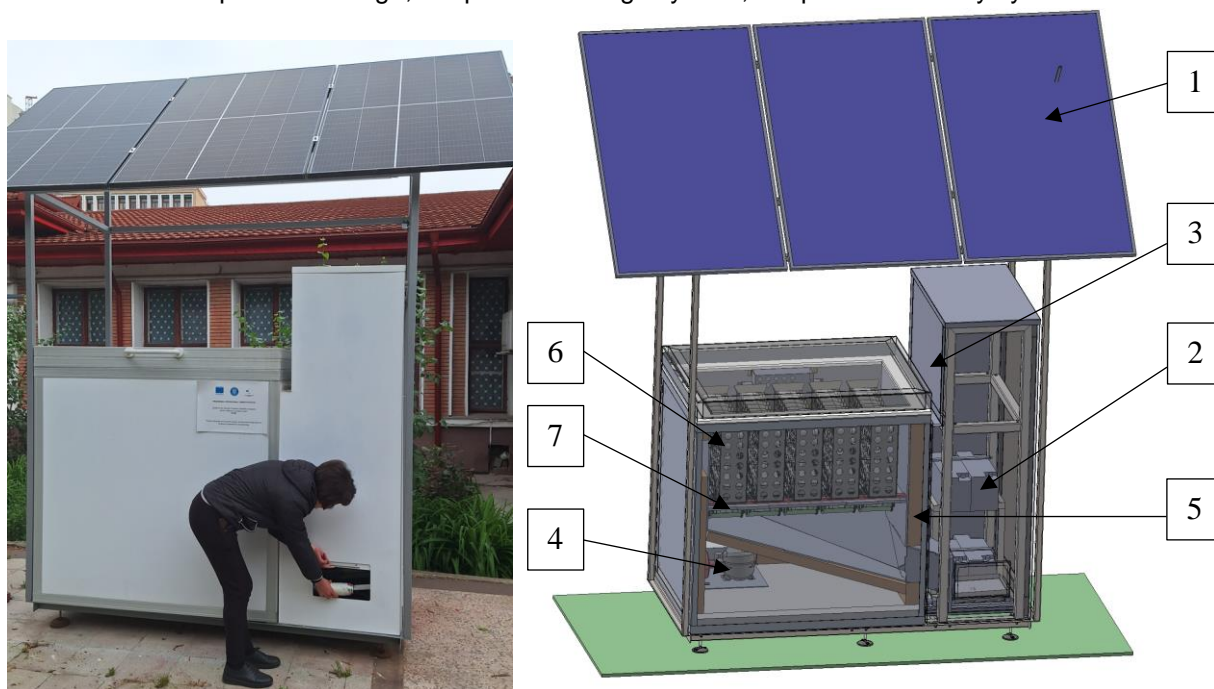

Fig. 2 – SVIEE-R system for selling agricultural products

The components illustrated in Fig. 2 of the SVIEE-R power supply system are: 1 - solar panels, type TSM, 405 DE09. 08, maximum power 405 W; 2 - batteries, type Victron GEL 12 v 130 AH; 3 - MPPT, type Victron 150/70 Tr. In Fig. 2 are shown: 4 - cooling system, 5 - thermally insulated enclosure, 6 - storage system, 7 - delivery system. The flow of electricity produced by the three photovoltaic panels is sent to the battery array and is managed by the MPPT type charge regulator. The MPPT regulator is known for their efficiency in converting the voltage from the photovoltaic panels to the battery charging voltage. The DC/DC conversion efficiency of these systems is 98% (****MPPT solar charger manual, 2024*).

The storage and delivery system for packaged agricultural products is shown in Fig. 3. The storage system consists of a sheet-metal casing with openings for ventilation and uniform cooling. The storage unit allows the storage of 32 containers with dimensions of 62 mm and height of 160 mm, the casing is designed in such a way that the containers move gravitationally which the product delivery system.

The operation analysis and evaluation of the electrical energy consumption of the delivery system was presented in the article “*Energetically efficient mechatronic systems for dose delivery in energetically independent vending machine for cold products*” (Savaniu et al, 2024), thus the average energy consumption for the delivery of one container is 1.115 W.

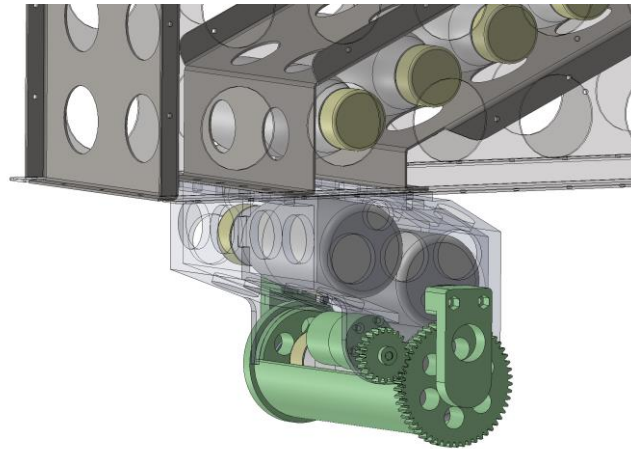

Fig. 3 – Delivery system for agricultural products packed in PET containers

The operation of the SVIEE-R implies in the first stage its supply with agricultural products packaged in Polyethylene terephthalate (PET) bottles which are stacked in the 5 storage units of the system located in the thermally insulated enclosure. From the thermally insulated enclosure the containers are unloaded by the delivery system, see Fig. 3, into the lower tank of the enclosure, from where they gravitationally reach the product pick-up area, see Fig. 2. The customer picks up the containers through the front delivery door, as shown in the picture in Fig. 2 where a person picks up the ordered product.

The SVIEE-R is equipped with a complex system of sensors whose measured values are continuously sent via the Internet to a server. The collected data is stored on the server to be later analyzed either in real time through an internet browser or downloaded as a database. The data stored on the server can be: temperature in the thermally insulated enclosure, ambient temperature, consumption for the refrigeration system [W], consumption for the product delivery system [W], data provided by the photovoltaic system via the MPPT solar charge controller (Battery [mV], Battery injected current [mA], Solar voltage [mV], Solar power [W], etc.).

The location of the SVIEE-R vending machine in rural areas requires a wind stability study. If a stability calculation is not carried out, it may happen that the vending machine may tip over, as shown in Fig. 4, when a similar vending system has been affected by wind action with very high intensity.

The stability of the vending machine is mainly determined by its mass, which in the case of the SVIEE-R vending machine, according to the data in Table 1 and applying formula (1) is 796.99 kg.

$$GV = TSSP + TSTLP + TSF \quad (1)$$



Fig. 4 – SVIEE vending machine overturned because of wind action

Table 1

No.	Name	Quantity	Density (kg/cm ³)	Total mass (Kg)
1	Thermal insulation Komacel 10 mm thick - cold room	101542.45 cm ³	5 x10 ⁻³	50.77
2	Thermal insulation Termoconfort 100 mm thick - cold room	955166.4 cm ³	0.034 x10 ⁻³	32.47
3	Thermal insulation BOND 3 mm thick - cold room	14444.44 cm ³	1.55 x10 ⁻³	22.39
4	Product storage system	5 trays	-	77.15
5	Metal structure made of aluminum profiles - cold room	1	-	20.62
6	Refrigeration installation (compressor. vaporizer. condenser. fan. support)	1	-	16.85
Total storage space for TSSP products				220.25
1	Outer casing - 3 mm thick steel sheet	1	-	80.44
2	External casing - 40 mm thick polystyrene thermal insulation	1	-	14.46
3	Product delivery system	1	-	8.65
4	Command and control system	1	-	2.43
5	Vendomat metal chassis	1	-	167.45
6	Metal structure supporting photovoltaic panels	1	-	85.01
Total technical and product delivery space TSTLP				358.44
1	GEL 12-130 batteries	4	-	152.00
2	Photovoltaic panels TSM 405-DE09.08	3	-	63.30
3	MPPT 150-70TR	1	-	3.00
Total photovoltaic system TSF				218.30

The stability study takes into account the forces acting on the machine as shown in Fig. 5. Thus, there is balance, in relation to the tipping edge, of the moments given by the force of weight given by the mass of the machine without being loaded with products and the force of weight of the counterweight made of concrete in relation to the moment generated by the force of wind action on the photovoltaic panels, as shown in Fig. 5. In order to ensure stability, which allows the safe use of the automat in open areas specific to the rural environment areas exposed to wind action, it is necessary to determine the size and then mount a counterweight at the base of the automat. The mass of the counterweight must be determined following a stability calculation.

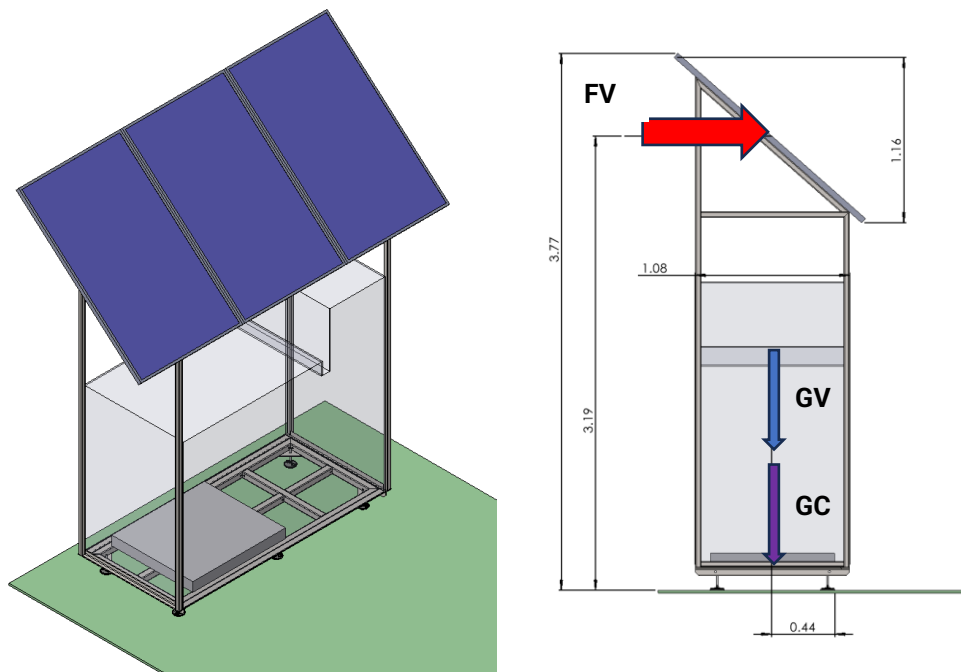

Fig. 5 – SVIEE-R vending stability calculation scheme

The tests on the validation of the commercialization of agricultural products by the SVIEE-R automat concerned dairy products packaged in plastic containers of the kefir and sana categories. Fermented dairy products, such as yoghurt, kefir, sana, buttermilk or fermented cream, must be kept at low temperatures to prevent the growth of micro-organisms that can spoil the product.

The optimal storage temperature is 2°C - 6°C, this temperature is provided by the product cooling system of the vending machine and the thermally insulated enclosure for product storage maintains this temperature, ensuring optimal storage of fermented dairy products. It is necessary to maintain this temperature range because below 2°C there is a risk of freezing, which can affect the texture and taste of the product, and above 6°C the risk of spoilage increases and the product may lose its properties, becoming unsafe for consumption. Storing at the correct temperature not only prevents spoilage but also helps to maintain the probiotic benefits of fermented products.



Fig. 6 – Loading the SVIEE-R with fermented dairy products. Temperature check with thermal camera.

The legislation in force in Romania, *The Sanitary Veterinary Regulation on additional conditions for the transportation, storage, marketing and veterinary sanitary control of milk and milk products* (***) *Sanitary Veterinary Regulation, 2004*) provides for the following for the marketing of agricultural dairy products: the optimal microclimate (temperature, humidity, ventilation) must be ensured for the product in question; for the purpose of its permanent control, the products must be arranged in an orderly manner, by assortment, lot or batch, and they must be visibly marked by means on which the assortment, quantity, date of entry of the product and the date of expiry of the shelf life must be obligatorily inscribed. Verification of the optimal temperature preservation of fermented dairy products consisted in feeding the vending machine with 25 containers loaded with sana, labeled S in Fig. 6 and 25 containers loaded with kefir, labeled K in Fig. 6. The containers had an average mass of about 350 g.

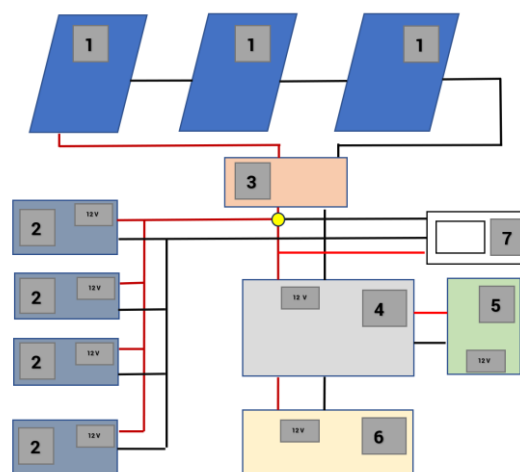

Fig. 7 – Block diagram of the SVIEE-R controller and current analyzer connection

The evaluation of the energy consumption of the SVIEE-R was carried out using a current analyzer type HIOKI PW3198 mounted according to the diagram in Fig. 8. The components of the electrical system of the energy independent vending machine are: 1 - solar panels, type TSM, 405 DE09. 08, maximum power 405 W; 2 - accumulators, type Victron GEL 12 v 130 AH; 3 - MPPT, type Victron 150/70 Tr; 4 - command and control system, of our own manufacture; 5 - cooling system powered at 12 V DC consisting of compressor, vaporizer, condenser; 6 - product delivery system, of our own manufacture; 7 - current analyzer type HIOKI PW3198.

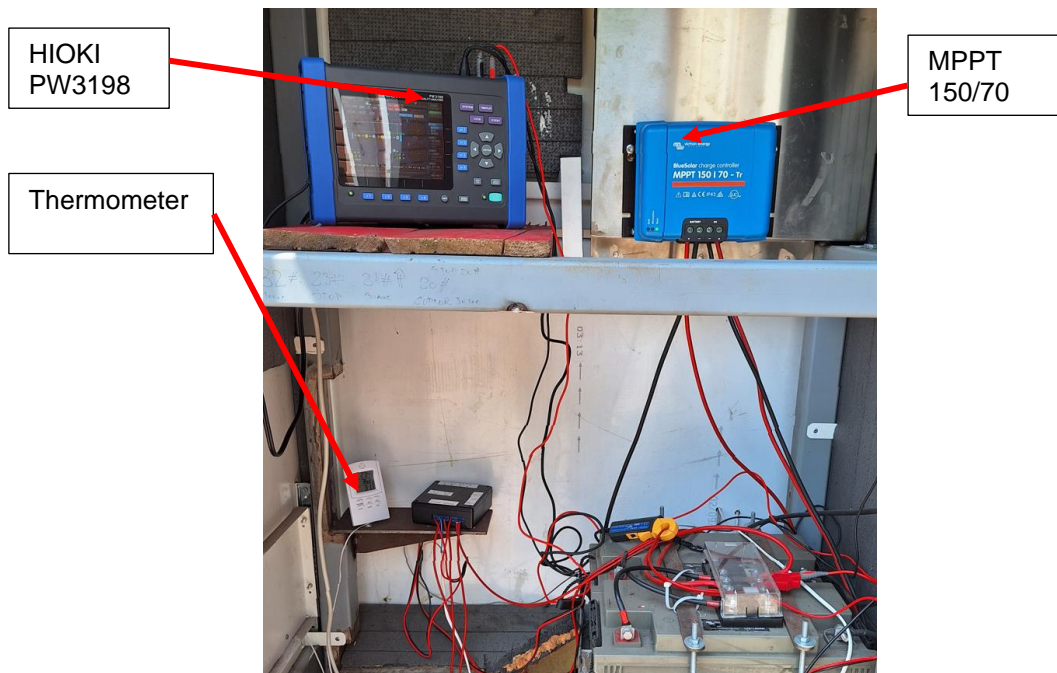

Fig. 8 – SVIEE-R command and control system

The HIOKI PW3198 power quality analyzer has the measurement accuracy Voltage: $\pm 0.1\%$ of nominal voltage; Current: $\pm 0.2\%$ rdg. $\pm 0.1\%$ f.s. + current sensor accuracy; Active power: $\pm 0.2\%$ rdg. $\pm 0.1\%$ f.s. + current sensor accuracy (** Hioki E.E. Corporation PQ ONE, 2024). The equipment, throughout the duration of the tests, collected data on supply voltage, current and electrical energy absorbed by the electromechanical actuator. The data stored in the storage medium of the equipment were analyzed with the PQ ONE software which allows the presentation of the values of the electrical energy absorbed by the electromechanical actuator in graphical or tabular form (** Hioki E.E. Corporation, 2024).

RESULTS

In order to verify the stability of the SVIEE-R vending machine to the variable action due to the wind, its action will be considered on the three photovoltaic panels placed at a height of about 3.19 m. Thus, according to the Design Code - Evaluation of Wind Action on Buildings - CR 1-1-4/2012 (** Indicative CR 1-1-4/2012) the average value of the dynamic wind pressure $q_m(z)$, acting on the solar panels, is determined by the formula:

$$q_m(z) = c_r^2(z) * q_b \quad (2)$$

where: $q_m(z)$ is the mean value of the dynamic wind pressure at a height z above the terrain (without taking into account the orography of the site); q_b is the reference value of the dynamic wind pressure (in the case of our tests, on the territory of Romania according to the map of CR 1-1-4/2012, the maximum reference value of the dynamic pressure can be 0.7 kPa); $c_r^2(z)$ is the roughness factor for the dynamic wind pressure (in case of location in terrain category II Open field - grassy terrain and/or with isolated obstacles (trees, buildings) at distances of at least 20 times the height of the obstacle) the case considered in the stability check for the location of the vending machine in rural areas. The value of the roughness factor, adopted according to the methodology of CR 1-1-4/2012, is 0.816.

In evaluating the stability of the SVIEE-R vending machine, a dynamic wind pressure value of 0.466 kPa at the solar panels was considered. Considering the area of a photovoltaic panel of 1.92 m² (length 1.754 m, width 1.096 m) and the area in the wind direction of 3.81 m² the total wind force is 1775.46 N.

Solving the equilibrium equation of moments (3), a counterweight value of 515.14 kg is obtained for the analyzed case of the SVIEE - R vending machine.

$$GC = \frac{3.19}{0.44} * FV - GV = 7.25 * 1775.46 N - 796.99 kg * 9.81 m/s^2 = 5053.61 N \quad (3)$$

The evaluation of the stability of the machine can also be done with the help of a simulation realized in SolidWorks. In this sense, the vending machine SVIEE-R was designed in the 3D virtual environment of SolidWorks, in order to simulate with the help of the Motion Analysis subroutine of SolidWorks the stability under the action of wind (** SolidWorks - Motion Analysis, 2022).

In this sense, the vending machine was placed in the virtual environment on a rigid flat surface, fixed in space, contact with a friction coefficient of 0.20 between the vending machine and the flat surface and the gravitational acceleration of 9.81 m/s^2 were considered. Using the Motion Analysis subroutine in SolidWorks the delivery system of cold products from the thermally insulated enclosure to the recipient was tested in a 3D virtual environment in which it was possible to run several working scenarios.

After running the simulations and using the tools provided by Motion Analysis, the stability of the automat was tested considering several working scenarios in terms of wind direction and counterweight size. The result obtained after running the simulator, for a scenario in which the automat loses its stability is shown in Fig. 9.



Fig. 9 – SolidWorks simulation of the loss of stability of SVIEE-R

The temperature maintenance and energy consumption tests were performed between 24/06/2023 and 25/06/2023. During the test period the average ambient temperature was 25.5 degrees Celsius. During this period, containers loaded with fermented dairy products were stored in the storage units in the thermally insulated enclosure of SVIEE-R. After loading, the SVIEE-R automat was started and the temperature inside the enclosure was checked at 15 min time interval with the thermometer mounted as shown in Fig. 8 and qualitatively with a PCE-TC24 thermal chamber, as illustrated in Fig. 6. The thermometer used had the temperature measuring range: $-5 \dots 50^\circ\text{C}$, measurement accuracy: $\pm 0.1^\circ\text{C}$. The thermal chamber had the temperature measuring range: $-20 \dots +380^\circ\text{C}$, measurement accuracy: $\pm 2^\circ\text{C}$. The average temperature recorded was 5.78 degrees Celsius.

The electrical energy consumption of the vending machine was recorded by the HIOKI PW3198 and the results regarding the voltage and current absorbed by the vending machine are presented in Fig. 10. After analyzing the collected data, an average consumption of 0.47 KW/h was recorded. Considering the 6.24 KW storage capacity of the automat there is an autonomy of about 13 hours in case there is no electricity production from photovoltaic panels.

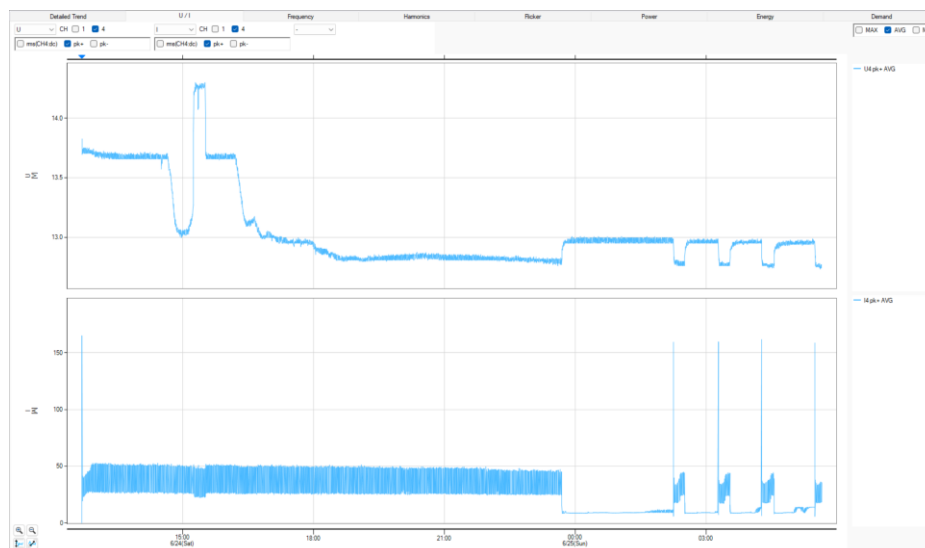

Fig. 10 – Current and voltage absorbed by SVIEE-R during the test period

CONCLUSIONS

Agricultural vending machines are more than a technological novelty; they represent a shift towards modernizing farming practices while maintaining inclusivity and sustainability. With proper implementation and support, they can revolutionize the way farmers access essential resources, boosting productivity and efficiency in the agricultural sector.

The research presented in the article recommends the use of the SVIEE-R energy independent vending machine in rural areas in order to co-market fermented dairy products at the farm gate. The use of the SVIEE-R energy independent vending machine ensures the safe commercialization of dairy food products by ensuring and maintaining a recommended refrigeration temperature for dairy products.

Providing the automat with an appropriate counterweight allows it to be placed anywhere, without the need for an additional foundation to anchor it. The automat is designed to be able to operate in the outdoor environment and in any environmental conditions.

The use of an energy-independent SVIEE-R has a significant impact on the environment and is intended for future sustainable agriculture - *Sustainable agriculture in the EU* (**Sustainable agriculture in the EU, 2024). SVIEE-R sales systems are intended for use on farms seeking to reduce greenhouse gas emissions. The supply of quantities of products tailored to the customer's requirements makes it possible to ensure that the food is always fresh and healthy and tailored to the customer's needs. Sales systems can determine the eating habits of specific communities and provide agricultural products 24 hours/7 days. The innovative energy efficient vending system SVIEE-R presented in the article is adapted to the European Green Deal adopted by the European Union, which assumes that by 2030 greenhouse gas emissions will be reduced by 55% (to 1990 levels), and a new binding EU-wide target has been set to improve energy efficiency by 11.7% by 2030. Member States will have to achieve annual savings of 1.49% on average between 2024-2030 (**The European Green Deal, 2024).

ACKNOWLEDGEMENT

This research was financially supported in part by the Competitiveness Operational Program—project name: Innovative Energy Efficient Sales Systems for Urban Areas (acronym, SVIEE, MySMIS code 121420), a co-financed project from the European Regional Development Fund by Operational Program Competitiveness.

FUNDING

This article was funded by UTCB - Technical University of Civil Engineering Bucharest, from Doctoral School funding (FCS).

REFERENCES

- [1] Rombach, M., Dean, D.L., Baird, T., Rice, J. (2022). Fruit Vending Machines as a Means of Contactless Purchase: Exploring Factors Determining US Consumers' Willingness to Try, Buy and Pay a Price Premium for Fruit from a Vending Machine during the Coronavirus Pandemic. *Covid*, 2(12), 1650-1665. <https://doi.org/10.3390/covid2120119>
- [2] Sabău, M. M., Mititean, P., Pocol, C. B., & Dabija, D.C. (2023). Factors Generating the Willingness of Romanian Consumers to Buy Raw Milk from Vending Machines. *Foods*, 12(11), 2193. <https://doi.org/10.3390/foods12112193>
- [3] Savaniu, M., Tonciu, O., Culcea M., Bizgan, A., Badea, F., Badea, C.R. (2024). Energetically efficient mechatronic systems for dose delivery in energetically independent vending machine for cold products. *International Journal of Mechatronics and Applied Mechanics*, Issue 15. DOI: 10.17683/ijomam/issue15.5
- [4] ***ZETOMAT Vending machines for fresh produce (Automate pentru vânzarea produselor proaspete), (2024), <https://zetomat.ro/>
- [5] ***Vending machines proving popular with producers, (2021). https://www.farminguk.com/news/vending-machines-proving-popular-with-producers_57970.html
- [6] ***On-farm sales solutions, (2024). <https://www.zuply.eu/branch/agriculture/>
- [7] ***Das Prinzip Regiomat, (2024). <https://www.regiomat.de/das-prinzip>
- [8] ***MPPT solar charger manual SmartSolar MPPT 150/70 up to 250/100 VE.Can, (2024). https://www.victronenergy.com/upload/documents/Manual_SmartSolar_MPPT_150-70_up_to_250-100_VE.Can/29694-MPPT_solar_charger_manual-pdf-en.pdf
- [9] *** Sanitary Veterinary Regulation on additional conditions for the transportation, storage, marketing and veterinary control of milk and milk products (Norma Sanitar Veterinară privind condițiile suplimentare pentru transportul, depozitarea, comercializarea și controlul sanitar veterinar al laptelui și produselor lactate), (2004), <https://legislatie.just.ro/public/DetaliiDocument/58860>
- [10] *** Hioki E.E. Corporation PQ ONE, (2024).
- [11] https://www.hioki.com/global/support/download/software/versionup/detail/id_562

- [12] *** Hioki E.E. Corporation, *Power Quality Analyzer PW3198*, (2024).
- [13] https://www.hioki.com/global/products/pqa/power-quality/id_5824
- [14] ***Design code assessment of wind action on buildings (*Cod de proiectare evaluarea actiunii vântului asupra constructiilor*), *Indicativ CR 1-1-4/2012*, 2012.
- [15] https://www.mdipa.ro/userfiles/reglementari/Domeniul_I/I_20_1_CR_1_1_4_2012.pdf
- [16] *** *SolidWorks – Motion Analysis*, (2022). <https://www.solidworks.com/>
- [17] *** *Sustainable agriculture in the EU*, (2024). https://agriculture.ec.europa.eu/sustainability_en
- [18] *** *The European Green Deal*, (2024). https://commission.europa.eu/strategy-and-policy/priorities-2019-2024/european-green-deal_en