

REVIEW OF AGRICULTURAL PLASTIC FILM RECYCLING EQUIPMENT FROM CHINA

/ 农膜回收装备研究现状及展望

Songmei YANG¹, Benxu WANG¹, Shaofeng RU^{*1}, Xuegeng CHEN², Limin YAN², Jilong WU¹¹School of Mechanical and Electrical Engineering, Hainan University, Haikou / China²School of Mechanical and Electrical Engineering, Shihezi University, Shihezi / China

Corresponding author: Shaofeng RU

Tel: +86089866295121; E-mail: rshaofeng@hainanu.edu.cn

DOI: <https://doi.org/10.35633/inmateh-74-61>**Keywords:** agricultural plastic film, pollution, recycling, machinery, mulch, polyethylene**ABSTRACT**

The treatment of polyethylene film in farmland mainly relies on residual film recycling machinery. However, there is a lack of detailed reports on the characteristics of agricultural residual film recycling machinery and guidance direction for further optimization. This article conducted a detailed literature review, first introducing the hazards of pollution. Then, the operational principles of residual film mechanized recycling equipment were explained from three aspects. Finally, the research direction of residual film pollution control equipment is clarified: it is urgent to reduce the impurity content in residual film and facilitate the resource utilization.

摘要

规模化地膜覆盖栽培技术在高寒干旱地区应用广泛。农田残留膜污染问题因其严重影响农田耕作质量、生态环境和农业可持续发展而备受关注。目前,可生物降解塑料薄膜尚未得到广泛应用,因此聚乙烯薄膜仍然是主流的塑料薄膜材料。农田聚乙烯薄膜的处理主要依靠残膜回收机械设备。然而,目前还没有关于农业残膜回收机械特性的详细报道,也缺乏对残膜回收机器进一步优化的相关指导方向。本文对农残膜回收机进行了详细的文献综述,首先介绍了农残膜污染的危害;然后,从三个方面阐述了操作原理:苗期地膜、耕作层残膜、表层全膜机械化回收设备;聚乙烯农用薄膜需要与农用薄膜、机械和农艺要求相结合,才能实现完全回收;最后,明确了残膜污染控制设备的研究方向:迫切需要降低残膜的杂质含量,促进残膜的资源化利用。

INTRODUCTION

Due to its versatility and lightness, plastic films are increasingly being used in various fields (Horodytska et al., 2018). For instance, plastic films are being used in express delivery, take-out tableware, and agricultural mulch films. Polyethylene film has become the fourth important agricultural production material after seeds, fertilizers, and pesticides (Deutsche Gesellschaft für Internationale Zusammenarbeit (GIZ) GmbH, 2022). Cultivation techniques of plastic film covering offers several advantages, including increased temperature and moisture, weed suppression, and increased crop yields, and is being used worldwide (Gao et al., 2019; Jiang et al., 2017). The use of agricultural film has been shown to increase the yield of cotton, corn, and other crops by approximately 30% (Jiang et al., 2023c). The application of agricultural plastic film planting technology in China has a history of about 40 years. Data from the past 5 years shows that the use of agricultural plastic film in China accounts for approximately 70% of the global total (Jin et al., 2020). In China, the plastic film planting rate of cotton in Xinjiang is 96.6%, while the peanuts and tobacco plastic film planting rates in Shandong Province and Hubei Province have reached 100% (Cui et al., 2024). Fig.1 illustrates the usage and coverage area of agricultural plastic film in China over the years (Liang et al., 2019), showing that China ranks first in the world in terms of coverage area and usage (Jiang et al., 2020).

However, with the widespread use of plastic films, while increasing crop yield, the issue of plastic film residues has also emerged. The accumulation of residual film from continuous mulching of farmland, coupled with the long-term use of ultra-thin farmland mulching films and inadequate awareness of the hazards of residual film pollution among farmers, has resulted in serious residue of farmland mulching films (Zhang et al., 2019a).

Songmei Yang, Lecturer; Benxu Wang, Postgraduate student; Shaofeng Ru, Associate Professor; Xuegeng Chen, Academician of Chinese Academy of Engineering; Limin Yan, Professor; Jilong Wu, Postgraduate student.

This residue hinders root growth and inhibits soil capillary action (Koskei *et al.*, 2021), affecting soil water holding capacity and the functional relationship between the microbial activity and water stable aggregates (de Souza Machado *et al.*, 2018), greatly impacting the quality of farmland cultivation and the ecological environment (Cao *et al.*, 2023a), and can even lead to a reduction in crop yield (Ding *et al.*, 2022b; Hu *et al.*, 2020). These large pieces of plastic film can further break down into micro/nano plastics with a particle size of less than 5 mm, and there is an annual trend of migration into deeper soil layers (Yan *et al.*, 2008). The content of microplastics pollutants in soil has exceeded that of marine ecosystems (Iqbal *et al.*, 2020). The presence of microplastics not only poses a threat to soil organisms and crop growth but also has the potential to contaminate groundwater and enter the food chain, thus endangering human health (Ding *et al.*, 2022a).

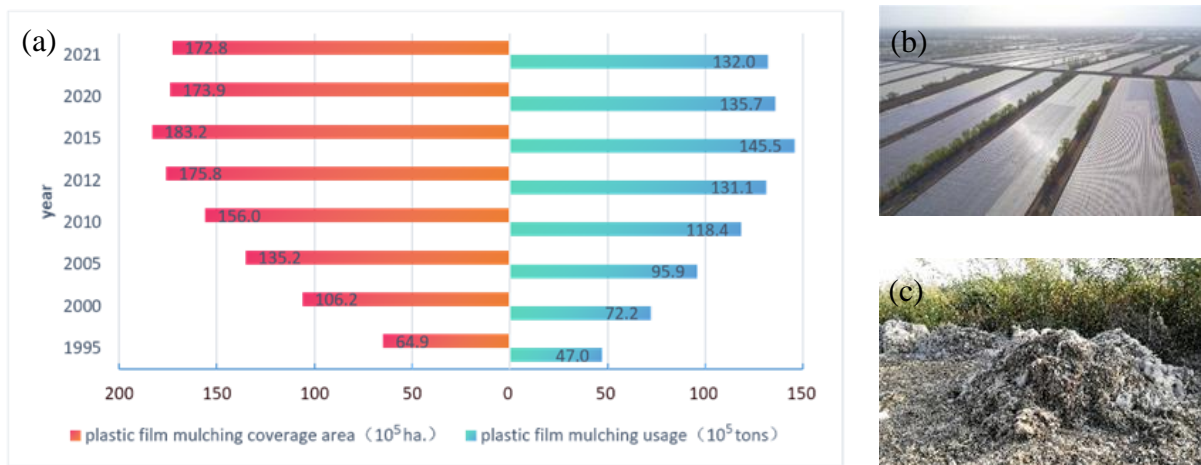

Fig. 1 -The use of agricultural film in China

(a) Annual usage and coverage area of agricultural plastic film in China; (b) Scenes after mulching and sowing in farmland; (c) Accumulation of residual film on the ground.

Polyethylene plastic film is known for its stability and can take decades or even hundreds of years to completely degrade (Niu *et al.*, 2023). Statistics show that the average plastic film residue intensity in China is $67.5 \text{ kg}\cdot\text{hm}^{-2}$ (Liang *et al.*, 2019). The Xinjiang Uygur Autonomous Region, which has the largest cotton planting area in China, experiences nearly 100% cotton mulching. Consequently, it is the region with the most severe agricultural plastic film pollution, with an average residue amount of $255.0 \text{ kg}\cdot\text{hm}^{-2}$ (Liu *et al.*, 2022). The arid climate and water resource shortages in regions like Inner Mongolia and Gansu have led to a significant use of mulch film, resulting in severe pollution from residual film. The average amount of residual mulch film in the crop layer is $127.1 \text{ kg}\cdot\text{hm}^{-2}$ (Yin *et al.*, 2022). Over time, the amount of residual plastic film in the tillage layer has been increasing (Yang *et al.*, 2023). According to estimates by scholars, the farmland in northwest China alone contains approximately 1.0×10^6 tons of residual macroplastics and 2.7×10^5 tons of residual microplastics as of 2020 (Cao *et al.*, 2023b).

The main methods of disposing polyethylene mulching film residues in farmland include landfilling and recycling. However, the agricultural film recycling rate in China is currently less than $2/3$ (Zhang *et al.*, 2021). Discarding and burying agricultural film waste resources are considered single-line economy methods (Dong *et al.*, 2022a; Lu *et al.*, 2023). On the other hand, recycling mulch film resources promotes a circular economy. Fig. 2 illustrates three main ways of reusing resources after recycling residual film. The recycled plastic film can be used for power generation, processed into plastic particles or wood plastic granules for subsequent production. From this, it can be seen that the recycling of agricultural residue film is a win-win measure, which is not only beneficial for environmental protection, but also for waste utilization.

In recent years, there has been significant attention given to biodegradable plastics due to their degradable properties. Biodegradable mulch films are considered as potential substitutes for polyethylene mulch films. However, the comprehensive performance of degradable mulch films is currently inferior to traditional polyethylene agricultural films in all aspects, and they also have a higher cost. Moreover, there are concerns about the potential risks and impact on the food chain (Ding *et al.*, 2022b; Shen *et al.*, 2020; Sintim *et al.*, 2021), which has limited their widespread promotion and application (Jiang *et al.*, 2023a). Therefore, until degradable mulch films can be widely adopted, polyethylene mulch films continue to be the primary choice for farmland.

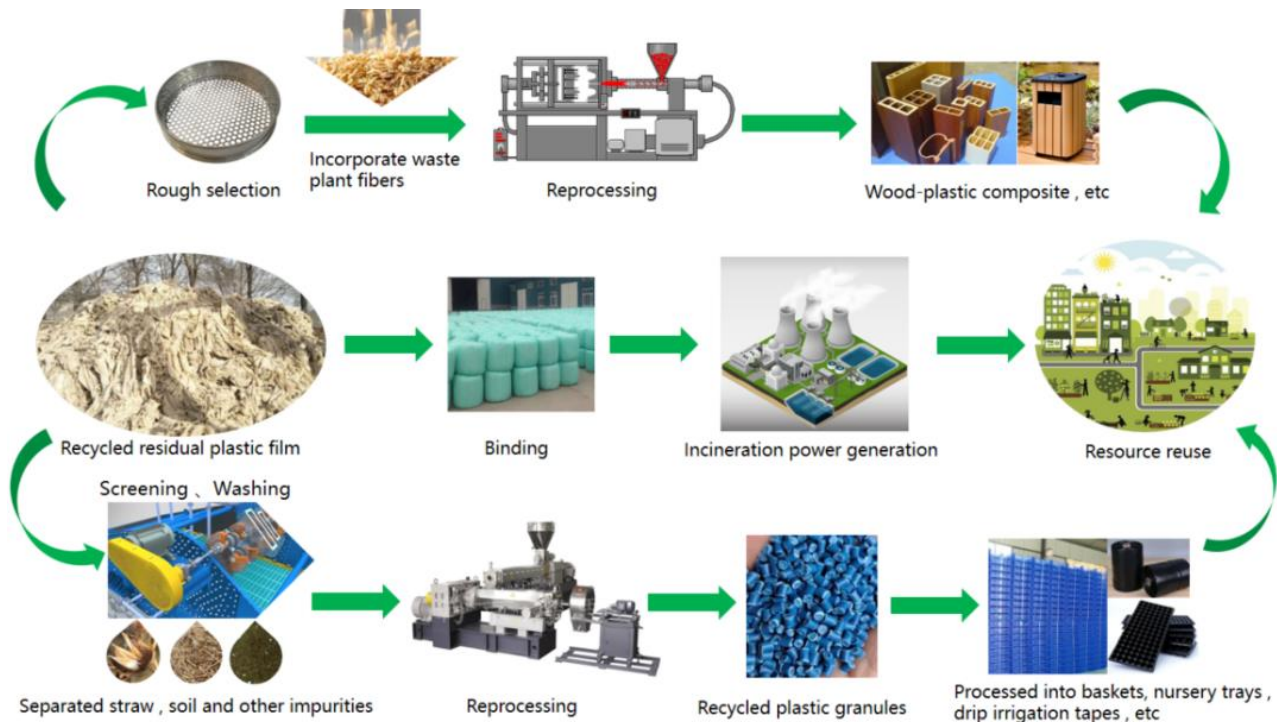

Fig. 2 - Three methods for reusing residual plastic film recycling resources

In summary, the primary task in treating residual film pollution in farmland is to recycle it. However, manual recycling has low efficiency, so mechanized recycling is an effective means to solve the problem of residual film pollution. This article summarizes the structural characteristics and applicable conditions of typical residual film recycling and post-treatment machinery, looks forward to the key technologies for residual film pollution control, provides reference for further optimization of residual film recycling machines, and puts forward suggestions for farmland residual film pollution control.

CURRENT RESEARCH STATUS OF PLASTIC FILM RECYCLING MACHINES

The issue of plastic film recycling is a global concern, and mechanical recycling is currently the most commonly used method to address this problem (Sica et al., 2015). In countries and regions such as Japan and Europe, agricultural mulch films with a minimum thickness of 0.02 mm are predominantly used (Jin et al., 2020), as depicted in fig. 3. Due to the thickness, strength, and durability of these films, a simple film rolling machine can effectively achieve the purpose of residual plastic film recycling, with simple machinery and high picking efficiency.

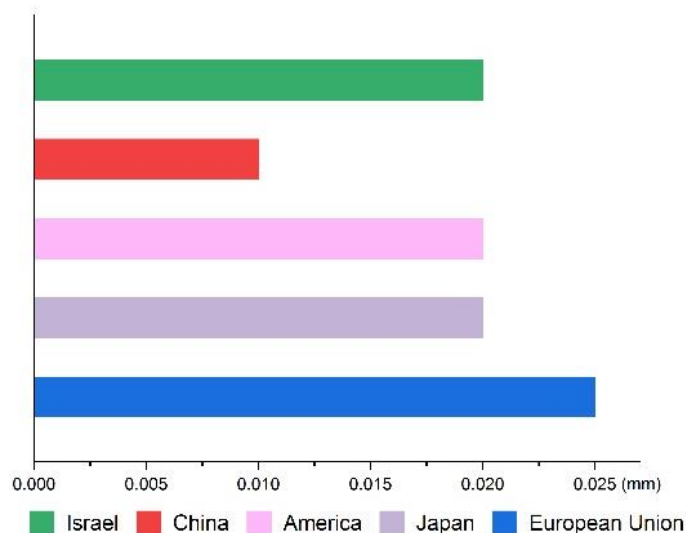

Fig. 3 - The thickness of applied plastic film in several representative countries

Before 2018, China's agricultural plastic film followed the national mandatory standard GB 13735-1992 'Polyethylene Blown Agricultural Mulch Covering Film' (Jin *et al.*, 2020). The standard stipulated that the thickness of the plastic film should be 0.008–0.02 mm. When the limit deviation of the plastic film with a thickness of 0.008 mm was ± 0.003 mm, it was considered a qualified product. As a result, plastic films with a thickness of 0.006–0.008 mm (Yan *et al.*, 2014) were commonly used due to their low cost, despite being easily damaged. Over the course of more than 20 years, the thinness of these films made them prone to aging, breaking, and tearing, thereby increasing the difficulty of recycling. Each year, the broken plastic film fragments mix into the soil, leading to the accumulation of microplastics. Moreover, the plastic film rolling machine cannot be used in this scenario. In May 2018, the revised national mandatory standard GB 13735-2017 'Polyethylene Blown Agricultural Mulch Covering Film' (Yang, 2020) was implemented. This new standard requires a minimum mulch film thickness of 0.01 mm and includes revisions to the tensile properties and weather resistance, resulting in better integrity of the recovered mulch film and facilitating mechanized recycling.

Based on the traditional agricultural film collecting operation time and process requirements, residual plastic film recycling machines can be categorized into three types: seedling stage plastic film recycling machines, post-autumn residual film recycling machines, and pre-sowing residual film recycling machines (Li *et al.*, 2020). With the advancement of mulch film standards, the integrity and strength of the residual film during recycling have improved. Therefore, considering the integrity of the residual plastic film and the operating principle of the residual plastic film recycling machine, the machine can be further classified into seedling stage residual film recycling machines, tillage layer residual film recycling machines, and surface whole film recycling machines. Both the seedling stage mulch recycling machine and the surface whole film recycling machine can recover the entire film. The difference is that the seedling stage mulch recycling machine needs to avoid the field seedlings during operation, whereas the tillage layer residual film recycling machine can be used to recycle broken residual film at any time after land preparation.

Seedling stage plastic film recycling machine

Recycling plastic film during the seedling stage refers to the collection of residual film covering the surface of crops before irrigation. During this stage, the mulch film is laid for a short period of time, resulting in minimal aging, good integrity, and little accumulation of soil and impurities. This makes it easier to mechanically remove the film. As a result, in areas with favorable irrigation conditions, some researchers have suggested recycling mulch films during the seedling stage.

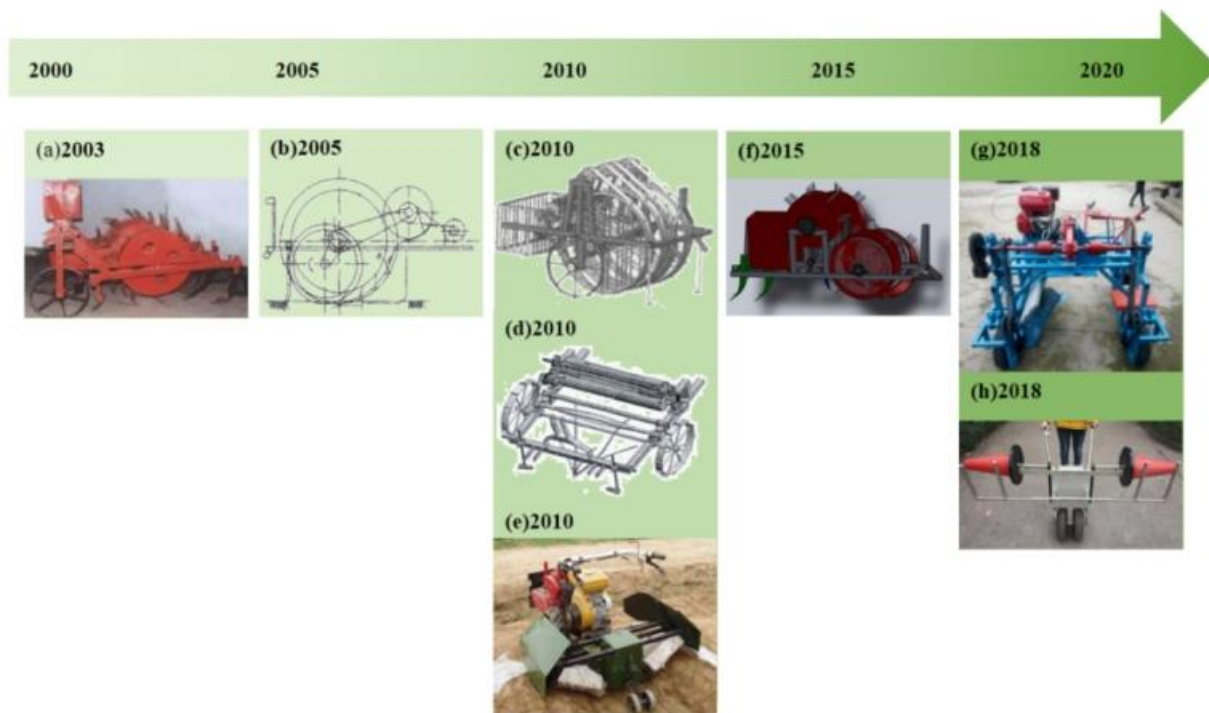

Fig. 4 - Representative seedling stage plastic film recycling machine

(a) MS-2 corn seedling stage film harvesting and tillage combined operation machine (Dong *et al.*, 2003) (b) Roll type cotton seedling residual film recycling machine (Xue *et al.*, 2005) (c) Plastic film collector for corn fields (Yang *et al.*, 2010b) (d) Plastic film collector for cotton fields during seedling period (Yang *et al.*, 2010a) (e) Plastic film collector in tobacco seedling stage (Cui, 2011) (f) Corn seedling film harvester (Wu, 2015) (g) Plastic film recycling machine for tobacco seedlings in mountainous areas (Liu, 2019) (h) Light and simple film stripper in tobacco seedling stage (Wang, 2019)

The cotton seedling stage residual film recycling machine (Xue et al., 2005) and the corn seedling stage film recycling and intertillage combined machine (Dong et al., 2003; Wu, 2015) as shown in the fig. 4 both utilize film rolling methods. In these machines, the film ends need to be manually wound on the film rolling wheel. When the remaining film roll reaches a certain level, the machine will stop, and then the film will be removed manually. This type of seedling residual film recycling machine may cause film tearing during the rolling process, while the floating synchronous film-rolling type seedling film recycling machine uses a floating synchronous film-rolling mechanism to effectively prevent film tearing, breakage, or retention (Yang et al., 2010a; Yang et al., 2010b).

Based on the analysis above, it is evident that the plastic film recycling machine used in the seedling stage often employs mulch film winding technology or a combination of film lifting mechanism to assist the winding machine. This approach is primarily utilized for mulch recycling in crops that do not require a significant increase in ground temperature during later stages of growth, such as corn. The mulch film recycling machine at the seedling stage takes on different forms depending on the crop variety, agronomic technology, and other requirements. However, it is important to note that recycling mulch films in the seedling stage can result in increased crop irrigation and soil compaction, particularly in dry agricultural areas that rely on drip irrigation technology under the film. Presently, there are limited methods available for recycling mulch films in the seedling stage.

Cultivated layer residual film recycling machine

The objective of recycling residual film in the tillage layer is to recover the blocky residual film present in the soil after plowing and levelling the land in spring, as well as the severely damaged plastic film after harvesting autumn crops. To address the issue of residual film pollution in the soil plow layer, various scientific research institutes have conducted studies on machines and tools for recycling residual film in farmland plow layer (Chen et al., 2020; Guo et al., 2020; Jin et al., 2018; Shi et al., 2019; Shi et al., 2023b; Wang et al., 2008; Zhang et al., 2019b). Currently, there are two main methods for recycling residual film in the tillage layer. The first method involves using an elastic toothed residual film recovery machine with a rake-like structure to gather the residual film together. The second method is the roller-type residual film recycling method, where a roller with multiple teeth is used. As the roller rotates, the residual film in the tillage layer adheres to the teeth and is then mechanically or pneumatically removed.

1. Elastic tooth type residual film recovery machine

The key components of the elastic tooth typed residual film recovery machine are typically made of manganese alloy materials such as No. 60 or 65 manganese steel and have an arc shape. During operation, the elastic tooth punctures the film and immediately collect it on the teeth for retrieval. The residual film is unloaded after reaching the end of the field. The elastic tooth type residual film recovery machine (Shi et al., 2017b) shown in fig. 5(a) only penetrates the film and requires manual removal. Some researchers have suggested adding a film unloading mechanism to the elastic toothed residual film recovery machine (Shi et al., 2017a; Tian, 2020; Tian et al., 2018; Wang, 2018), which allows for the completion of film collecting, stripping, and unloading processes in a single operation, thereby enhancing the efficiency of residual film recovery.



Fig. 5 - Representative tooth type residual film recovery machine

(a) tooth type residue plastic film collector of ridged peanut (Shi et al., 2017b). (b) Cotton stalk chopping and residual plastic film collecting combined operation Machine (Tian, 2020; Tian et al., 2018) (c) Standing cotton stalks raking-film machine with wide folding and monomer profiling (Wang, 2018; Wang et al., 2017)

Compared with other forms of residual film recycling machines, the elastic tooth type residual film recovery machine has a lower recovery rate of residual film, typically around 50%, and a high impurity content rate. However, it has gained wide usage in Xinjiang, Gansu, and Inner Mongolia in China due to its simple structure, low cost, and high operating efficiency.

2. Roller type residual film recycling machine

Fig. 6 illustrates various types of roller-type residual film recovery machines. These machines take advantage of the roller's rotation during operation. When it reaches the lowest point, the teeth of the roller penetrates the residual film, and a stripping device is positioned to remove the film, thus completing the residual film recycling operation. The roller-type residual film recovery device, as shown in Fig. 6(b) (Zhang, 2023; Zhang et al., 2023), features pick-up teeth installed on the outer edge of the roller. The pick-up roller collects the residual plastic film, and the stripping device removes it from the roller, depositing it in the film collection box to complete the residual film recovery operation. The corn full-film double-furrow residual film recovery machine as illustrated in fig. 6(e) (Dai et al., 2016), which differs from the previous devices in that it uses an eccentric pickup roller to collect the residual film. After the film is stripped off by the stripping device, it is rolled up and recycled by the film rolling roller, which is driven by ground wheels to maintain synchronicity. The strip-shaped residual film baling machine, as shown in fig. 6(f) (Niu et al., 2017), is specifically designed for picking and packaging strip-shaped residual film. This machine effectively removes most impurities through two operations involving the impurity cleaning roller and the eccentric pickup roller.

Each roller-type residual film recycling machine operates based on different working principles, with the main distinction being the working principle of its core component — the pickup roller. The pickup device in the roller-type residual film recovery machine can be categorized into two types: concentric roller-type pickup device and eccentric roller-type pickup device. This classification is based on the relative motion relationship between the pickup teeth and the roller, as well as the positional relationship between the center line of the pickup teeth assembly and the center line of the roller.

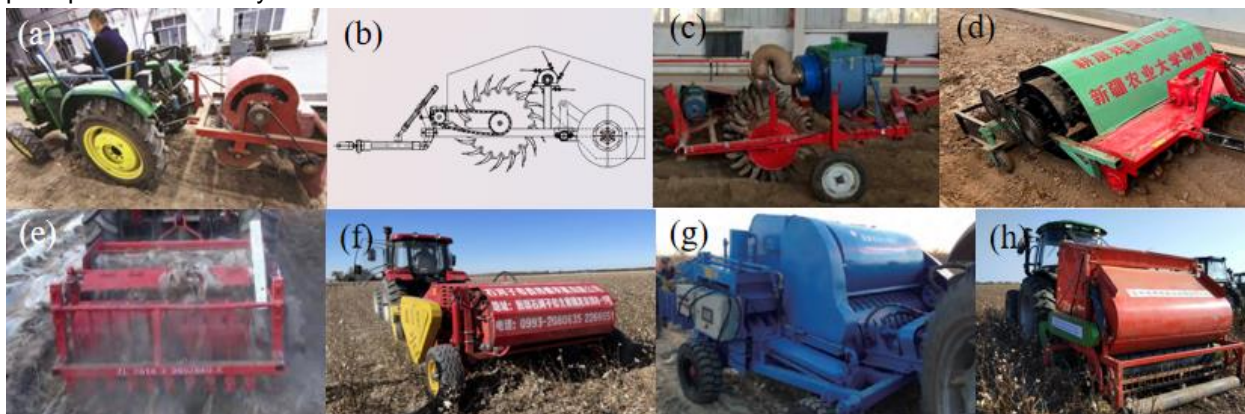

Fig. 6 - Representative roller-type residual film recovery machines

(a) Nail-teeth roller-type residual film recovery device (Chen et al., 2020);

(b) 1SMB-3600A residual film recycling machine (Zhang, 2023; Zhang et al., 2023); (c) Comb toothed pneumatic film removal type plow layer residual film recovery machine (Guo et al., 2020); (d) Roller type residual film recovery machine (Shi et al., 2023b); (e) Collector for corn whole plastic film mulching on double ridges (Dai et al., 2016); (f) Collecting and Separating Device for Strip Plastic Film Baler (Niu et al., 2017); (g) Roller-type elastic tooth residual film recovery machine (Liu, 2023); (h) 4JSM-2000 type combined operation machine for cotton stalk chopping and plastic film recovery (You, 2021; You et al., 2017b)

2.1. Concentric roller-type pickup device

The pick-up elastic teeth and the roller in the concentric roller-type pick-up device are typically combined into a single unit without any relative movement between them. The rotation center lines of the two components coincide with each other. 1SMB-3600A type fragmented film collector (Zhang, 2023; Zhang et al., 2023) which features a residual film pickup roller with arc-shaped teeth, as depicted in fig. 7. The residual film pickup roller and the film stripping roller rotate in opposite directions during operation. The film-picking teeth on the roller pick up the residual film from the tillage layer and transport it to the stripping area. Subsequently, the residual film attached to the teeth is peeled off by the stripping roller and collected in the residual film collection device.

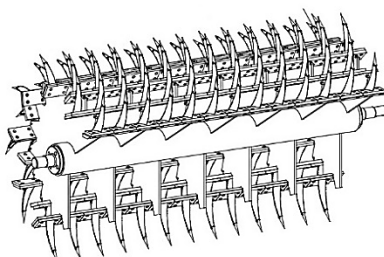

Fig. 7 - Roller of 1SMB-3600A type fragmented film collector

2.2. Eccentric roller-type pickup device

The pickup teeth and the roller of the eccentric roller-type pickup device can move relative to each other. There are two forms of the eccentric roller based on its principle: the eccentric shaft type and the crankshaft type. In the eccentric shaft type, the residual film pickup teeth assembly rotates synchronously with the roller, but their center lines do not coincide. The elastic teeth expand and contract through the strip holes on the roller (Niu et al., 2017; You et al., 2017a), as shown in fig. 8(a). On the other hand, in the crankshaft type, the residual film pickup elastic teeth are installed on the connecting rod of the crankshaft at the shaft diameter position. The elastic teeth can rotate relative to the connecting rod shaft diameter, while the pickup roller remains fixed and collinear with the center of the crankshaft. As the crankshaft rotates, the elastic teeth expand and contract through the holes on the roller (Dai et al., 2016; Jin et al., 2018; Niu et al., 2017), as shown in fig. 8(b). Regardless of the form of the eccentric roller used, the pickup teeth and the roller undergo relative radial movement to pick up the residual film. When the elastic teeth are fully extended, they pick up the residual film. As the elastic teeth shrink, the residual film is picked up by them and returned to the roller for film removal. This marks the beginning of the impurity cleaning and residual film collection stage.

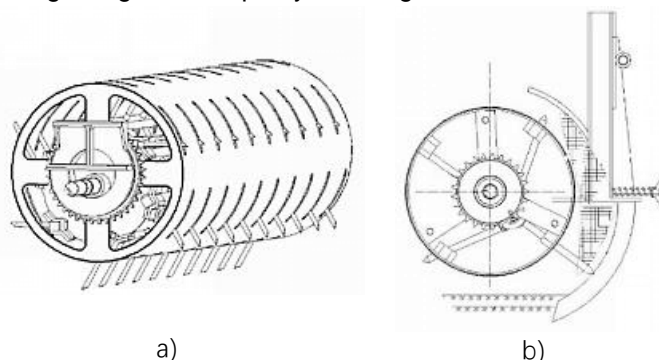

Fig. 8 - Schematic diagram of eccentric roller structure.
(a) Eccentric shaft roller (b) crankshaft eccentric roller

The advantage of the roller-type residual film recycling machine is its high work efficiency. The concentric roller-type residual film recycling machine is suitable for recycling small pieces of broken plastic film, while the eccentric roller type residual film recycling machine is more suitable for recycling large pieces of plastic film. This is due to the relative movement between the pickup teeth and the roller of the eccentric roller-type residual film recycling machine. It is easy to accumulate in the opening of the roller if the broken small pieces of film are not removed promptly from the elastic teeth, resulting in issues such as poor movement of the elastic teeth or even blockage.

In addition to the two methods mentioned above for recovering residual film from the tillage layer, there is also a screening method available (Luo et al., 2018; Xu et al., 2017; Yan et al., 2017; You et al., 2017c), as shown in fig. 9.



Fig. 9 - Screening type residual film recovery machine.
(a) Shovel screen residual film recycling machine (Yan et al., 2017; You et al., 2017c); (b) Chain screen cultivator residue film recycling machine (Luo et al., 2018); (c) Net chain peanut residue film recycling machine (Xu et al., 2017)

During the operation of the screening-type residual film recovery machine, the soil lifting mechanism is responsible for transporting the soil from the tillage layer to the screening device. The soil is then filtered under the action of vibration, allowing the collection of the residual film. Typically, these machines are equipped with an excavation shovel at the front of the unit. This method is particularly effective for collecting smaller residual film fragments. The film-soil mixture is excavated by the shovel and directed to the vibration separation mechanism, where the soil is separated from the remaining film. It is important to note that this type of machine has a large and complex structure, as well as high power consumption.

Surface film recycling machine

In arid areas or areas where under-film drip irrigation is used, residual film is typically recycled after the crops are harvested. This recycling process does not have any negative impact on the quality of the crops, and is currently the mainstream method of residual film recovery. The implementation of the national standard GB 13735-2017 'Polyethylene Blown Agricultural Mulching Film' has significantly improved the performance of mulching film after crop harvest, ensuring its integrity and strength. As a result, Chinese scientific researchers have developed various tooth chain-type residual film recycling machines for surface film recycling (Cao *et al.*, 2023c; Jiang *et al.*, 2019; Jiang *et al.*, 2023b; Jin *et al.*, 2022; Wen *et al.*, 2021; Yang *et al.*, 2020; Yang *et al.*, 2021; Yang *et al.*, 2018).

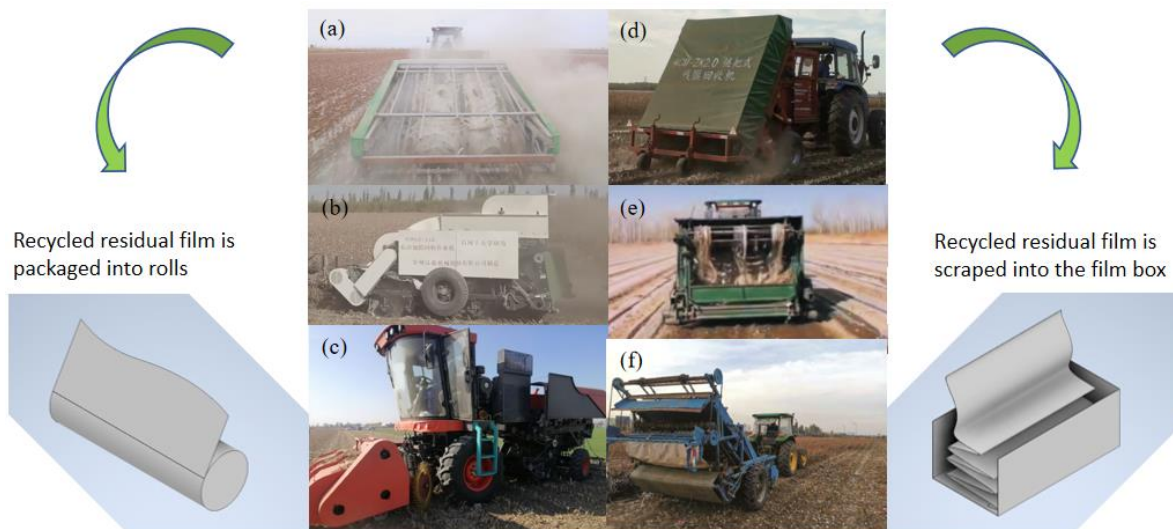

Fig. 10 - Representative model of tooth-chain-type residual film recycling machine.

(a) Passive cotton field residual plastic film recycling machine (Yang, 2020; Yang *et al.*, 2018). (b) Second stage chain plate straw crushing and plastic film recycling combined operation machine (Wen *et al.*, 2021). (c) Self-propelled straw crushing and residual film recycling combined operation machine (Jiang *et al.*, 2023a). (d) Side row cotton straw returning and residual plastic film recycling combined operation machine (Cao *et al.*, 2023c; Xie *et al.*, 2020). (e) Vertical double-row chain residual film recycling machine (Shi *et al.*, 2023a). (f) Clamping finger-chain type residual film collector (Duan, 2017; Tang *et al.*, 2020)

The tooth-chain-type residual film recovery machine is commonly used in conjunction with the straw return machine to perform joint operations. This machine can simultaneously crush cotton stalks and recover residual film, thereby improving operational efficiency and reducing land compaction. The tooth-chain-type residual film recycling machine is capable of performing multiple functions such as soil entry, film lifting, impurity cleaning, film stripping, and film collection. Its main operating component is a ring-shaped device composed of a tooth-chain that can pick up and transport plastic film. The straw returning machine breaks down straw into pieces and transports them to the ground on both sides or behind the unit where the residual film has been collected. During the process of straw breaking, the straw return machine creates negative pressure which helps remove light impurities from the membrane surface, thus creating favorable conditions for the operation of the residual film recovery machine. The tooth-chain-type residual film recovery machine, as shown in fig. 10 (a)-(c), allows for easy packaging of the residual film into film rolls for transportation and processing. Similarly, the tooth-chain-type residual film recovery machine shown in fig. 10(d)-(f) collects the residual film and places it into a film collecting box.

The device shown in fig. 11 (a) is the key core component of the recycling machine in fig. 10(a). The pickup, impurity cleaning, and film removal device in fig. 11(a) cleverly flips the film surface with the movement of the chain, allowing impurities to fall into the screw conveyor for removal. The device shown in fig. 11 (b) is the key core component of the recycling machine in fig. 10 (d), which transports the mulch film upwards using elastic teeth and a supporting plate, with the angle of the elastic teeth adjusted for effective stripping. Additionally, the tooth-chain-type residual film recovery machine also has vertical double-row chain-type (Shi *et al.*, 2023a), which utilizes the angle of the chain row arrangement for convenient impurity removal and film stripping under the force of gravity. In addition to mechanical cleaning devices, residual film removal devices can also use methods such as air flow assisted impurity removal (Peng *et al.*, 2023).

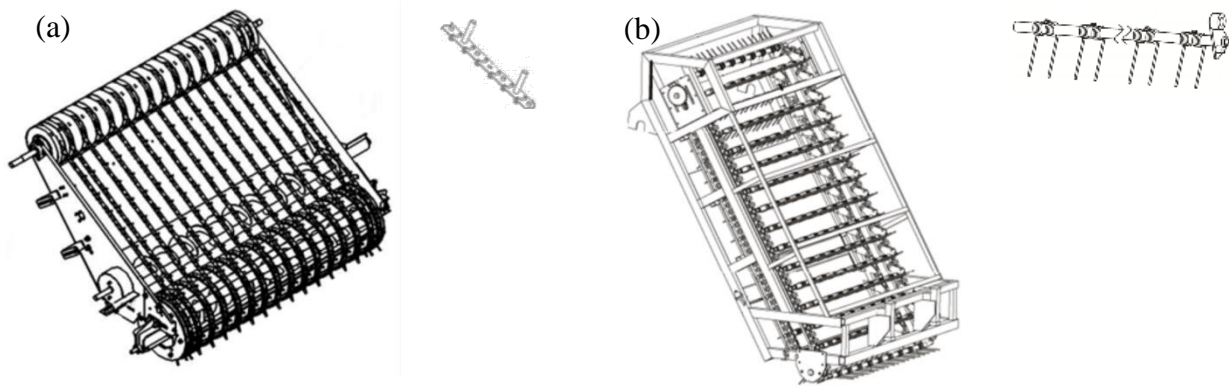

Fig. 11 - Key core components of the tooth-chain-type residual film recycling machine

(a) Key core components of the passive residual film recycling machine;

(b) The key core components of the side row cotton straw returning and residual plastic film recycling combined operation machine

There is no significant correlation between the amount of mulch film in farmland soil, the planting pattern, and the age of the mulch film. However, it is related to the recovery rate of residual film in the current season (Wang *et al.*, 2020). Therefore, the solution to the problem of residual film pollution in farmland is to completely recycle the mulch film laid in the current season, gradually recycle the film fragments in the soil (Zhao *et al.*, 2017). The tooth chain type residual film recovery machine can effectively recycle the entire film and has the advantage of a high recovery rate of residual film. In recent years, research has focused on improving the impurity removal rate and film unloading efficiency. This area shows good prospects for industrial development. Currently, there are agricultural machinery enterprises conducting small-scale trial production and demonstration and promotion.

RESIDUAL FILM POST-TREATMENT EQUIPMENT

The research on equipment for recovering agricultural residue film has achieved preliminary results (Dong *et al.*, 2022b; Lv *et al.*, 2015; Yang, 2005; Zhang, 2015). However, the mechanically recycled residual film is often contaminated with impurities like soil and straw, making it challenging to directly process it into plastic particles for reuse. To address this issue, residual film post-processing equipment plays a crucial role in effectively separating the residual film from impurities. This separation process is beneficial for subsequent processing and reuse of the residual film, contributing to its resource utilization.

According to different separation principles, residual film and impurity separation technology can be divided into three categories: air separation, electrostatic separation, and water washing separation. Various equipment has been developed based on the different physical properties of the residual film and impurities as depicted in fig. 12, which exhibit different behaviors in wind, electrostatic fields, and water.



Fig. 12 - Representative residual film post-treatment equipment

(a) Trommel sieve type film miscellaneous wind separator (Kang *et al.*, 2022). (b) Washing and separation device of residual film mixture collected by machine (Li, 2018). (c) Film-stubble separation device under high-voltage electrostatic adsorption (Li, 2023)

A roller screen type film and impurity air separator, which utilizes the combined action of roller screen rotation and air blowing to disperse the film and impurity mixture (Kang *et al.*, 2022; Peng *et al.*, 2020). The residual film with a smaller density is blown towards the circular film collecting box at the end of the cylindrical screen, while impurities such as cotton stalks with high density and high suspension speed are thrown out from the sieve holes of the cylindrical screen through inertia. The mechanism of film-stubble separation under high-voltage electrostatic adsorption was studied (Li, 2023; Li *et al.*, 2022). After bench testing, it was found that the residual film adsorption rate was 90%, while the separation rate of residual film and impurities was 78%. However, further improvements are still needed. A water washing and separation device for mechanical collection of residual film mixture was developed (Hu *et al.*, 2024; Li, 2018; Li *et al.*, 2019). This device can separate the residual film and impurities based on the different positions of the floating layer of the material in the vortex flow field of the water tank.

URGENT RESEARCH WORK TO BE CARRIED OUT

Residual film recovery rate and impurity content rate are two important evaluation indicators for residual film recovery, but they are mutually exclusive. When recycling the residual film, film picking teeth are inserted into the soil to lift the plastic film from the ground. However, if the entire film is recycled, impurities such as soil and straw on the surface of the plastic film cannot be removed immediately and will be wrapped in the film roll or collected in the film collecting box. A higher recovery rate of residual film requires the device to penetrate the soil deeply during the pick-up stage, resulting in a higher impurity content rate, and vice versa. Although current residual film recycling machinery achieves a high recovery rate, it still faces the challenge of high impurity content. The recycled residual film becomes mixed with straw and soil, making it difficult to separate. In particular, the high soil content hinders resource utilization. Therefore, in the forthcoming research, our focus will be on upgrading or improving the technology to reduce the impurity content of the residual film while maintaining a high recovery rate.

SUMMARY AND OUTLOOK

The ultimate trend is to replace polyethylene mulch films with degradable films, and national standards have been established for fully biodegradable agricultural ground covering films (Lin *et al.*, 2024). However, since the environmental impact of fully biodegradable mulch films is currently unknown (Min *et al.*, 2022), polyethylene mulch films will continue to be the dominant choice for the next 10 years or so, resulting in a long coexistence period between the two. The use and recycling/degradation conditions of PE film and biodegradable film are different, as shown in fig. 13. Research units in China have conducted studies on recycling equipment for polyethylene residual films, designing different machines based on different crops and production models. Through extensive practice, it has been determined that only the combination of agronomy, agricultural machinery, and agricultural film can create basic conditions for the mechanized film recycling effectively. By gradually removing the old residual plastic film in the soil without generating new film residue, the content of residual film in the soil will decrease over time. Mechanized recycling of residual film is an essential step towards achieving this. After mechanized recycling, the residual film can be transformed into a valuable resource, contributing to a circular economy and providing raw materials for processing enterprises. This approach is beneficial for environmental protection and sustainable development. Therefore, developing an efficient and practical residual film recycling machine holds great practical significance.

This article provides a review of the recent advancements of residual film recycling machinery and post-processing technology and equipment in China. The aim is to enhance recycling efficiency and reduce environmental pollution. However, the utilization of polyethylene mulch films requires more than just the availability of corresponding technology and equipment. It necessitates government guidance on the use of compliant mulch films, departmental supervision and implementation, national participation in governance, centralized recycling at outlets, initial deep processing by enterprises, and comprehensive resource utilization. These measures are essential for effectively promoting the recycling and reuse of waste agricultural films, mitigating 'white pollution' in the fields, and achieving a 'win-win' situation for ecological and social benefits. Therefore, in future agricultural production, in addition to technical aspects, it is crucial to steadily promote agricultural film pollution control from the following perspectives:



Fig. 13 - Usage conditions of PE agricultural film and degradable film

To control the thickness of agricultural film and minimize plastic pollution, it is crucial to use a high-strength weather-resistant film of a certain thickness. This will prevent the film from breaking into small pieces during harvest and enable mechanized recycling without damage. By completely recycling the film that very year and gradually reducing the stock of residual film in farmland, the goal of reducing volume and increasing efficiency can be achieved. To accomplish this, it is essential to strengthen market supervision, enforce standardized quality for agricultural mulch films, set higher requirements for suppliers, prohibit the use of recycled materials in agricultural mulch films, establish a quality tracking mechanism, and ensure compliance with national standards for agricultural film thickness.

To ensure the recovery rate of mulch film, it is important to clarify the goals and responsible persons for leaving residual film from the fields. Currently, plastic film recycling and processing in China is extensive. However, it is necessary to establish clear responsibilities and obligations for government departments at all levels, producers, sellers, and users. This will help improve the waste plastic film recycling system. Specifically, the responsibilities and obligations of film users for leaving residual film from the fields should be defined, and strict measures should be implemented to control the recycling rate of residual plastic film that very year.

To improve the number and coverage areas of residual film recycling outlets and reuse companies, it is crucial to address the current challenges. Our investigation reveals that many farmers either loosely recycle the residual film during land preparation in autumn or directly incorporate it into the soil without any recycling methods. A major contributing factor is the lack of recycling outlets for residual film. Even if farmers are willing to recycle the residual film, the absence of recycling outlets forces them to either accumulate it in the fields or resort to burning. Therefore, it is essential to establish recycling outlets in areas where agricultural film is extensively used. One approach is to support relevant cooperatives in a planned manner, enabling them to undertake the comprehensive management of residual film on farmland. Additionally, it is important to provide support to waste film reuse enterprises. These measures will enhance farmers' willingness to recycle residual film and improve the overall recovery rate.

ACKNOWLEDGEMENT

The authors were funded for this project by Hainan Provincial Natural Science Foundation of China (521QN0869) and Hainan Provincial Academician Innovation Platform Research Project (SQ2021YSPTJXRWS0011).

REFERENCES

- [1] Cao, J., Gao, X., Cheng, Z., Song, X., Cai Y., Siddique, K.H., Zhao X., Li, C. (2023a). The harm of residual plastic film and its accumulation driving factors in northwest China. *Environmental Pollution*. 318:120910.
- [2] Cao, J., Gao, X., Hu, Q., Li, C., Song, X., Cai Y., Siddique, K.H., Zhao, X. (2023b). Distribution characteristics and correlation of macro- and microplastics under long-term plastic mulching in northwest China. *Soil and Tillage Research*, 231:105738.
- [3] Cao, S., Xie, J., Yang, Y., Liu, Y., Lu, Y., Sun, B. (2023c). Design and experiment of side row cotton straw returning and residual film recovery combined machine. *Journal of Jilin University (Engineering and Technology Edition)*, 53(05):1514-1528.
- [4] Chen, X., Chen, X., Li, J., Li, C., Yang Y. (2020). Design and test of nail-teeth roller-type residual film recovery device before sowing. *Transactions of the Chinese Society of Agricultural Engineering*, 36(02):30-39.
- [5] Cui, F. (2011). *Study on Used Plastic Film Collector in Tobacco Seedling Stage*. [Master's thesis, Shandong Agricultural University].
- [6] Cui, J. X., Xu, J. Z., Bai, R. H., Liu, Q., He, W. Q., Yan, C. R. (2024). Analysis of the behavior and driving forces of the application, recovery, and management of plastic mulch film by farmers in typical areas of China. *Journal of Agricultural Resources and Environment*. 41 (01):175-186.
- [7] Dai, F., Zhao, W., Zhang, F., Wu, Z., Song, X., Wu, Y. (2016). Optimization and experiment of operating performance of collector for corn whole plastic film mulching on double ridges. *Transactions of the Chinese Society of Agricultural Engineering*, 32(18):50-60.
- [8] de Souza Machado A.A., Lau C.W., Till J., Kloas W., Lehmann A., Becker R., Rillig M.C. (2018). Impacts of microplastics on the soil biophysical environment. *Environmental Science Technology*, 52, 9656-9665.
- [9] Deutsche Gesellschaft für Internationale Zusammenarbeit (GIZ) GmbH (2022). Analysis Report on Current Status of PE Mulch Film Application in China & 2022 Series Report of Sino-European Sustainable Transition Towards Circular Economy. *Sino-German Project for Upgrading Plastics Management in Agriculture*.
- [10] Ding, F., Jones, D. L., Chadwick, D. R., Kim, P. J., Jiang, R. and Flury, M. (2022a). Environmental impacts of agricultural plastic film mulch: Fate, consequences, and solutions. *Science of The Total Environment*. 836:155668.
- [11] Ding, F., Yan, C. and Wang, J. (2022b). An Overlooked Issue in Black Soil Protection: Plastic Film Accumulation and Pollution. *Chinese Journal of Soil Science*. 53(01):234-240.
- [12] Dong, H., Yang, G., Zhang, Y., Yang, Y., Wang, D., Zhou, C. (2022a). Recycling, disposal, or biodegradable-alternative of polyethylene plastic film for agricultural mulching? A life cycle analysis of their environmental impacts. *Journal of Cleaner Production*. 380:134950.
- [13] Dong, J., Li, S., Bi, X., Wang, G., Wang, J., Wang, W., Tong, N. (2022b). Design and Experimental Research of a New Film-Picking Mulch Film Recovery Machine with Impurity Separation Function. *Process*. 10(3):455.
- [14] Dong, X., Na, M., Li, Y., Zhang, H., Yang, X., Hou, S. (2003). Research on MS-2-type corn seedling stage film harvesting and tillage combined operation machine. *Journal of Agricultural Mechanization Research*. 2003(02):175-176.
- [15] Duan, W. (2017). Design of clamping finger-chain type device for recycling agricultural plastic film. [Master's thesis, Shihezi University].
- [16] Gao, H., Yan, C., Liu, Q., Ding, W., Chen, B., Li, Z. (2019). Effects of plastic mulching and plastic residue on agricultural production: A meta-analysis. *Science of The Total Environment*. 651:484-492.
- [17] Guo, W., He X., Wang L., Zhao P., Hu C., Hou S., Wang X. (2020). Development of a comb tooth loosening and pneumatic stripping plough layer residual film recovery machine. *Transactions of the Chinese Society of Agricultural Engineering*, 36(18):1-10.
- [18] Horodytska, O., Valdés F. J., Fullana A. (2018). Plastic flexible films waste management – A state of art review. *Waste Management*. 77:413-425.

- [19] Hu, B., Yuan C., Xie Y., Guo, M., Luo, X., Pan, F., Li J. (2024). Design and test of cutting film and removal impurities device based on negative pressure conveying of water pump. *Journal of Jilin University (Engineering and Technology Edition)*, 2024, (1): 268-280. DOI: 10.13229/j.cnki.jdxbgxb.20221045.
- [20] Hu, C., Wang X. F., Wang S. G., Lu B., Guo W. S., Liu C. J., Tang X. Y. (2020). Impact of agricultural residual plastic film on the growth and yield of drip-irrigated cotton in arid region of Xinjiang, China. *International Journal of Agricultural and Biological Engineering*. 13(1):160-169.
- [21] Iqbal S., Xu J., Allen S.D., Khan S., Nadir S., Arif M.S., Yasmeen T. (2020). Unraveling consequences of soil micro- and nano-plastic pollution on soil-plant system: implications for nitrogen (N) cycling and soil microbial activity. *Chemosphere*, 260, 127578.
- [22] Jiang, D., Chen X., Yan L., Mo Y., Yang S., Wang Z. (2019). Optimization of working parameters of cleaning system for master-slave residual plastic film recovery machine. *Transactions of the Chinese Society of Agricultural Engineering, China*, 35(19):1-10.
- [23] Jiang, D., Chen X., Yan L., Yang J., Li Y. (2023a). Mechanical and friction properties of agricultural plastic film during autumn harvest period of cotton in Xinjiang, China. *Environmental Science and Pollution Research*. 30(38):89238-89252.
- [24] Jiang, D., Chen X., Yan L., Zhang R., Wang Z., Wang M.E. (2020). Research on technology and equipment for utilization of residual film in farmland. *Journal of Chinese Agricultural Mechanization*. 41(01):179-190.
- [25] Jiang, D., Yan L., Chen X., Mo Y., Yang J. (2023b). Design and experiment of nail tooth picking up device for strip type residual film recycling and baling machine. *International Journal of Agricultural and Biological Engineering*. 16(6):85-96.
- [26] Jiang, H., Lei Q., Zhang B., Wu S. (2023c). Effects of Mulching and Application of Organic and Chemical Fertilizer on Greenhouse Gas Emission and Water and Nitrogen Use in Summer Maize Farmland. *Environmental Science*. 44(06):3426-3438.
- [27] Jiang, X. J., Liu W. J., Wang E. H., Zhou T. Z., Xin P. (2017). Residual plastic mulch fragments effects on soil physical properties and water flow behavior in the Minqin Oasis, northwestern China. *Soil and Tillage Research*. 166:100-107.
- [28] Jin, T., Xue Y. H., Zhang M. M., Zhou T., Liu H. J., Zhang K., Xi B. (2020). Research Advances in Regulations, Standards and Recovery of Mulch Film. *Ecology and Environmental Sciences*. 29(02):411-420.
- [29] Jin, W., Liu J., Xu C., Zhang X., Bai S. (2022). Design, Simulation and Experimentation of a Polythene Film Debris Recovery Machine in Soil. *Applied Sciences*, 12: 1366.
- [30] Jin, W., Zhang, X., Yan, J., Yuan, P., Bai, S., Fang, X. (2018). Characteristic analysis and working parameter optimization of crankshaft type cotton field surface residual film collecting machine. *Transactions of the Chinese Society of Agricultural Engineering, China*, 34(16):10-18.
- [31] Kang, J., Xie C., Wang X., Chen Y., Wang C., Peng Q. (2022). Design and test of screen hole clearing device for trommel sieve type membrane miscellaneous wind separator. *Transactions of the Chinese Society for Agricultural Machinery*. 53(09):91-98.
- [32] Koskei, K., Munyasya A. N., Wang Y. B., Zhao Z. Y., Zhou R., Indoshi S. N., Xiong Y. C. (2021). Effects of increased plastic film residues on soil properties and crop productivity in agro-ecosystem. *Journal of hazardous materials*. 414: 125521.
- [33] Li, D., Zhao W., Xin S., Liu X., Qu H., Xu Y. (2020). Current situation and prospect of recycling technology of farmland residual film. *Journal of Chinese Agricultural Mechanization*. 41(05):204-209.
- [34] Li, J. (2018). Study on the water- separating device of residual film mixture collected by machine. [Master's thesis, Shihezi University].
- [35] Li, J., Luo X., Hu B., Wang M., Yao Q. (2019). Research and Experiment of the Water-separating Device for Residual Film Mixture. *Journal of Agricultural Mechanization Research*. 41(05):152-156.
- [36] Li, X. (2023). Design and experiment of membrane - stubble separation device under high voltage electrostatic adsorption. [Master's thesis, Tarim University].
- [37] Li, X., Xing J., Hu C., Wang L., Guo W., He X., Wang X. (2022). Application and Development Prospect of Electrostatic Technology in Agriculture. *Xinjiang Agricultural Mechanization*. (01):18-21+46.
- [38] Liang, R., Chen X., Zhang B., Meng H., Jiang P., Peng X., Li W. (2019). Problems and countermeasures of recycling methods and resource reuse of residual film in cotton fields of Xinjiang. *Transactions of the Chinese Society of Agricultural Engineering, China*, 35(16):1-13.

- [39] Lin, J., Li, X., Chai, X., He, C. (2024) Comparison of aging properties of starch/ PBAT degradable mulching film in different environments. *Acta Materiae Compositae Sinica*. 2024:1-8.
- [40] Liu, C. (2023). Design and research of drum elastic tooth residual film recovery machine. [Master's thesis, Shihezi University].
- [41] Liu, Y., Zhou, M., Zhai, X. (2022). Will participating in the agricultural film recycling affect the income of farmers? Case study in Xinjiang. *Journal of Arid Land Resources and Environment*. 36(03):59-66.
- [42] Liu, Z. (2019). Development and experiment of a plastic film recycling machine for tobacco seedlings in mountainous areas. [Master's thesis, Guizhou University].
- [43] Lu, L., Li, W., Cheng, Y., Liu, M. (2023). Chemical recycling technologies for PVC waste and PVC-containing plastic waste: A review. *Waste Management*. 166:245-258.
- [44] Luo, K., Yuan P., Jin W., Yan J., Bai S., Zhang C., Zhang X. (2018). Design of chain-sieve type residual film recovery machine in plough layer and optimization of its working parameters. *Transactions of the Chinese Society of Agricultural Engineering, China*, 34(19):19-27.
- [45] Lv, Z., Zhang L., Zhang G., Liu S. (2015). Design and test of chain guide rail-type plastic film collector. *Transactions of the Chinese Society of Agricultural Engineering, China*, 31(18):48-54.
- [46] Min, W., Wang C., Wang L., Yi T., Bian J., Zhi M., Zhao X. (2022). Effects of Biodegradable Film Raw Material Particles on Soil Properties, Wheat Growth, and Nutrient Absorption and Transportation. *Environmental Science* 43(01):560-568.
- [47] Niu, A., Wu J., Zhao X. (2023). Infrared Spectrum Analysis of Degradation Characteristics of PPC Plastic Film Under Different Covering Methods. *Spectroscopy and Spectral Analysis*. 43(02):533-540.
- [48] Niu, Q., Ji C., Zhao Y., Chen X., Zheng X., Li H. (2017). Design and Experiment on Collecting and Separating Device for Strip Plastic Film Baler. *Transactions of the Chinese Society for Agricultural Machinery*. 48(05):101-107.
- [49] Peng, Q., Li C., Kang J., Shi G., Zhang H. (2020). Improved Design and Test on Pneumatic Cylinder Sieve Film Hybrid Separator. *Transactions of the Chinese Society for Agricultural Machinery*. 51(08):126-135.
- [50] Peng, Q., Li K., Wang X., Zhang G., Kang J. (2023). Design and Test of Stripping and Impurity Removal Device for Spring-Tooth Residual Plastic Film Collector. *Agriculture*. 13(1):42.
- [51] Shen, M., Song B., Zeng G., Zhang Y., Huang W., Wen X., Tang W. (2020). Are biodegradable plastics a promising solution to solve the global plastic pollution? *Environmental Pollution*. 263:114469.
- [52] Shi, L., Hu Z., Gu F., Wu F., Chen Y. (2017a). Design on automatic unloading mechanism for teeth type residue plastic film collector. *Transactions of the Chinese Society of Agricultural Engineering*, 33(18):11-18.
- [53] Shi, L., Z. Hu, F. Gu, Wu F., Wu P. (2017b). Design and parameter optimization on teeth residue plastic film collector of ridged peanut. *Transactions of the Chinese Society of Agricultural Engineering*, 33(02):8-15.
- [54] Shi, Z., Tang X., Zhen J., Yan J., Zhang X., Jin W. (2019). Performance test and motion simulation analysis of nail tooth type mechanism for collecting plastic residue. *Transactions of the Chinese Society of Agricultural Engineering*, 35(04):64-71.
- [55] Shi, Z., Zhang X., Cheng J., Zhou X., Zhang C. (2023a). Design and test of film transfer and unloading device of vertical double-row chain residual film recycling machine. *Agricultural Research in the Arid Areas*. 41(03):257-265.
- [56] Shi, Z., Zhang X., Liu X., Kang M., Yao J., Guo L. (2023b). Analysis and Test of the Tillage Layer Roll-Type Residual Film Recovery Mechanism. *Applied Sciences*. 13(13):7598.
- [57] Sica, C., Dimitrijevic A., Scarascia-Mugnozza G., Picuno P. (2015). Technical Properties of Regenerated Plastic Material Bars Produced from Recycled Agricultural Plastic Film. *Polymer-Plastics Technology and Engineering*. 54(12):1207-1214.
- [58] Sintim, H. Y., Bandopadhyay S., English M. E., Bary A., Liquet y González J. E., DeBruyn J. M., Flury M. (2021). Four years of continuous use of soil-biodegradable plastic mulch: impact on soil and groundwater quality. *Geoderma*. 381:114665.
- [59] Tang, Y., Yongman Z., Wang J., Wang Z. (2020). Design and experiment of film removing device for clamping finger-chain type residual film collector. *Transactions of the Chinese Society of Agricultural Engineering*, 36(13):11-19.
- [60] Tian, X. (2020). *Design and Research of Cotton stalk crushing and Film casting combined working Machine*. [Master's thesis, Shihezi University].

- [61] Tian, X., Zhao Y., Chen X., Yan L., Wen H., Gou H., Ji C. (2018). Development of 4JSM-2000A type combined operation machine for cotton stalk chopping and residual plastic film collecting. *Transactions of the Chinese Society of Agricultural Engineering*, 34(10):25-35.
- [62] Wang, K. (2018). *Design and study on standing cotton stalks raking-film machine with wide folding and monomer profiling*. [Master's thesis, Shihezi University].
- [63] Wang, K., Hu B., Luo X., Chen X., Zheng X., Yan L., Gou H. (2017). Design and experiment of monomer profiling raking-film mechanism of residue plastic film collector. *Transactions of the Chinese Society of Agricultural Engineering*, 33(08):12-20.
- [64] Wang, X., Shi J., Guo J., Chen F. (2008). Experimental study and design on film raking mechanism of hanging film raker with cotton-stalk crushing and returning to field. *Transactions of the Chinese Society of Agricultural Engineering*, (01):135-140.
- [65] Wang, X. R., Wang K. R., Li Y. C., Wang B., Liu J., Wang F. L., Song N. N. (2020). Analysis on pollution situation of mulch film residual in farmland soils in QINGDAO city, *Fresenius Environmental Bulletin*. 29(7A):5822-5829.
- [66] Wang, Y. (2019). Design and Study on Simplified Film Stripper for Tobacco Seedling. [Master's thesis, Southwest University].
- [67] Wen, H., Gou H., Chen X. (2021). Development of a second-order chain plate straw crushing and plastic film recycling combined operation machine. *Agricultural Development & Equipments*, 235(07):40-41.
- [68] Wu, S. (2015). *Design and Experiment of Picking Up Film Removing Mechanism of Film Machine on Corn Seedling*. [Master's thesis, Northeast Agricultural University].
- [69] Xie, J., Yang Y., Cao S., Zhang Y., Zhou Y., Ma W. (2020). Design and experiments of rake type surface residual film recycling machine with guide chain. *Transactions of the Chinese Society of Agricultural Engineering*, 36(22):76-86.
- [70] Xu, H., Hu Z., Wu F., Gu F., Wei H., Yan J. (2017). Design and experiment of network chain type residual plastic film collector for peanut field. *Transactions of the Chinese Society of Agricultural Engineering*, 33(17):1-9.
- [71] Xue, W., Wang C., Zhu Z., Wang X. (2005). Design of a Roll Film Cotton Seedling Residual Film Recycling Machine. *Transactions of the Chinese Society for Agricultural Machinery*, (03):148-149+147.
- [72] Yan, C., Liu E., Shu F., Liu Q., Liu S., He W. (2014). Review of Agricultural Plastic Mulching and Its Residual Pollution and Prevention Measures in China. *Journal of Agricultural Resources and Environment*, 31(02):95-102.
- [73] Yan, C., Wang X., He W., Ma H., Cao S., Zhu G. (2008). The residue of plastic film in cotton fields in Shihezi, Xinjiang. *Acta Ecologica Sinica*, 28(07):3470-3474.
- [74] Yan, W., Hu Z., Wu N., Xu H., You Z., Zhou X. (2017). Parameter optimization and experiment for plastic film transport mechanism of shovel screen type plastic film residue collector. *Transactions of the Chinese Society of Agricultural Engineering*, 33(01):17-24.
- [75] Yang, D. (2005). Research on loosening shovel and curl-up film roller of the Machine for Retrieving the used plastic film after harvesting. Master's degree. [Master's thesis, China Agricultural University].
- [76] Yang, L., Heng T., He X., Yang G., Zhao L., Li Y., Xu Y. (2023). Spatial-temporal distribution and accumulation characteristics of residual plastic film in cotton fields in arid oasis area and the effects on soil salt transport and crop growth. *Soil and Tillage Research*. 231:105737.
- [77] Yang, L., Liu J., Zhang D., Hou S., Xu F. (2010a). Design and Experiment of plastic Film Collector for Cotton Fields during Seedling Period. *Transactions of the Chinese Society for Agricultural Machinery*. 41(S1):73-77.
- [78] Yang, L., Zhang D., Hou S., Xu F. (2010b). Analysis of Structural Parameters and Experiment of Plastic Film Collector for Corn Fields During Seedling Period. *Transactions of the Chinese Society for Agricultural Machinery*. 41(12):29-34.
- [79] Yang, S. (2020). Design and Key Technology Research of Passive Cotton Field Residual Plastic Film Recycling Machine. [Doctoral dissertation, Jilin University].
- [80] Yang, S., Chen X., Yan L., Jiang D. (2020). Performance of three different spades for residual plastic film recycling machine. *Applied Engineering in Agriculture*, 36(2):187-195.
- [81] Yang, S., Chen X., Yan L., Mo Y., Jiang D., Zhang H. (2021). Design and experiment on belt-type curl-up film device for residual plastic film recycling machine. *Transactions of the Chinese Society for Agricultural Machinery*, 52(02):135-144.

- [82] Yang, S., Yan L., Mo Y., Chen X., Zhang H., Jiang D. (2018). Design and Experiment on Collecting Device for Profile Modeling Residual Plastic Film Collector. *Transactions of the Chinese Society for Agricultural Machinery*, 49(12):109-115+164.
- [83] Yin, S., Zhao B., Mi J., Liu H., Guo X., Wu Y., Liu J. (2022). Current scenario and future trends of plastic film residue in farmland topsoil in Inner Mongolia, China. *Journal of Agro-Environment Science*, 41(09):1985-1992.
- [84] You, J. (2021). *Design and test of 4JSM-2000 type combined operation machine for cotton stalk chopping and plastic film recovery*. [Doctoral dissertation, Shenyang Agricultural University].
- [85] You, J., Chen X., Zhang B., Wu J. (2017a). Design and experiment of 4JSM-2000 type combined operation machine for cotton stalk chopping and residual plastic film collecting. *Transactions of the Chinese Society of Agricultural Engineering, China*, 33(10):10-16.
- [86] You, J., Zhang B., Wen H., Kang J., Song Y., Chen X. (2017b). Design and Test Optimization on Spade and Tine Combined residual Plastic Film Device. *Transactions of the Chinese Society for Agricultural Machinery*. 48(11):97-104.
- [87] You, Z., Hu Z., Wu H., Zhang Y., Yan J., Yan W., Zhou X. (2017c). Design and experiment of 1MCDS-100A typed shovel-sieve residual film recovery machine. *Transactions of the Chinese Society of Agricultural Engineering, China*, 33(09):10-18.
- [88] Zhang, B. (2015). *Design and Study of Film Recycling Film Recycling Machine in Autumn*. [Master's thesis, Xinjiang Agricultural University].
- [89] Zhang, B., Wang Z., Jin S. (2019a). Current situation and prospect of agricultural film pollution treatment in China. *World Environment*, (06):22-25.
- [90] Zhang, Q.Q., Ma Z.R., Cai Y.Y., Li H.R., Ying G.G. (2021). Agricultural Plastic Pollution in China: Generation of Plastic Debris and Emission of Phthalic Acid Esters from Agricultural Films. *Environmental Science Technology*, 55(18):12459-12470.
- [91] Zhang, X., Liu J., Shi Z., Jin W., Yan J., Yu M. (2019b). Design and parameter optimization of reverse membrane and soil separation device for residual film recovery machine. *Transactions of the Chinese Society of Agricultural Engineering*, 35(04):46-55.
- [92] Zhang, Z. (2023). *Study on the mechanism of picking up and recovering the residual film of sowing layer based on arc-shaped nail-tooth roller*. [Doctoral dissertation, Shihezi University].
- [93] Zhang, Z., Li J., Wang X., Zhao Y., Xue S., Su Z., Liang J. (2023). Design and test of 1SMB-3600A type fragmented mulch film collector for sowing layer soil. *Soil and Tillage Research*, 225:105555.
- [94] Zhao, Y., Chen X., Wen H., Zheng X., Niu Q., Kang J. (2017). Research Status and Prospect of Control Technology for Residual Plastic Film Pollution in Farmland. *Transactions of the Chinese Society for Agricultural Machinery*, 48(06):1-14.