

DESIGN AND MECHANISM STUDY OF SEED FILLING ROOM WITH STAGGERED ORIENTED PLATES AND VIBRATION

交叉导流式振动种箱设计与机理研究

Zhiye MO, Fangyuan LU^{*}, Mengqi ZHANG, Chong TAO, Bolong WANG, Guohai ZHANG¹

School of Agricultural Engineering and Food Science, Shandong University of Technology, Zibo/ China

Tel: +8615288942032; E-mail: fangyuan-lu@foxmail.com

Corresponding author: Fangyuan Lu

DOI: <https://doi.org/10.35633/inmateh-72-58>

Keywords: seed filling room, staggered oriented plates, Electromagnetic vibration, rice seeds

ABSTRACT

Aiming at the existing rice mechanized seeding technology it is difficult to meet the hybrid rice low seeding volume precision seeding requirements. In this paper, based on the friction characteristics of rice seed and the theory of silo arching, the structure and parameters of seed filling room with staggered oriented plates and vibration in the quantitative seed supply device were designed. EDEM software was used to simulate the working process of the quantitative seed supply device, and it was determined that staggered oriented plates structure in the seed filling room combined with vibration could effectively prevent seed arching, thus improving the uniformity of seed supply. Finally, the results of the simulation analysis were verified by rice quantitative seed supply test. The results showed that the vibration could increase the seed supply frequency by 3.64% for large sowing weight of conventional rice and 5.52% for small sowing weight of hybrid rice. In addition, the analysis of the coefficient of variation of the seed supply frequency by quantitative seed supply devices showed that the vibration effect could increase the stability of seed supply device by 2.47 % for the conventional rice seed and 1.33 % for the hybrid rice seed, which increased the seed supply stability.

摘要

针对现有的水稻机械化播种技术难以满足杂交稻低播量精密播种要求的问题, 本文基于稻种摩擦特性及料仓结拱理论, 设计了定量供种装置内交叉导流式振动种箱结构参数。采用 EDEM 软件对定量供种装置的工作过程进行了离散元仿真模拟, 确定了种箱内交叉导流结构结合振动作用能够有效防止种子结拱, 从而提高供种均匀性。通过水稻定量供种试验, 对仿真分析结果进行验证, 得到振动作用可提高常规稻大播量供种频率 3.64%, 提高杂交稻低播量供种频率 5.52%; 通过定量供种装置供种频率变异系数分析, 表明振动作用在常规稻供种时可提高供种稳定性 2.47%, 杂交稻提高 1.33%, 增加了供种稳定性。

INTRODUCTION

The varieties of rice grown in China are divided into conventional rice and hybrid rice, with more than 50% of the area planted in hybrid rice due to its remarkable high-yield characteristics. Among them, the planting technology of hybrid rice that obtains high yield through strong tillering ability requires less sparse planting 1-2 plants/hole (or seedling area) of seedling quantity (Dan., 2020; Li et al., 2021; Song et al., 2023). To realize hybrid rice planting with fewer plants, it is necessary to improve the uniformity of sowing and adopt the precision sowing technology with low sowing rate (Han et al.2023; Ma et al., 2023; Song et al, .2023). However, it is difficult to realize precision seeding technology due to the growth characteristics of rice, that require seeding after germination, and the high water content of the seeds, which are easy to be broken by force (Tian et al., 2022; Xia et al., 2023; Yang et al., 2023). The experiments showed that the quantitative seed supply performance of the two-stage and double-vibration rice seedling precision planter investigated in this paper has a significant impact on the realization of low seeding rate of hybrid rice.

Therefore, based on the theories of discrete element method, vibration mechanics and granular mechanics, this paper established a theoretical model of effective separation and uniform flow of rice seeds under vibration, analyzed the dynamic characteristics of rice seeds under the action of seed filling room with

¹ Zhiye Mo, M.S. Stud. Eng.; Fangyuan Lu, As. Ph.D. Eng.; Mengqi Zhang, M.S. Stud. Eng.; Chong Tao, M.S. Stud. Eng.; Bolong Wang, As. Ph.D. Eng.; Guohai Zhang, As. Ph.D. Eng.

staggered oriented plates and vibration, and studied the seed supply mechanism of the quantitative seed supply device. Through theoretical analysis combined with experimental research, the motion conditions of rice seed in seed supply device were analyzed, and the working parameters of seed supply device were optimized to improve the seed supply precision and sowing stability of hybrid rice.

MATERIAL AND METHODS

Main structure and principle

The rice seedling precision sowing quantitative seed supply device is shown in Figure.1. It is mainly composed of seed box, first seed oriented plate, electromagnetic vibration plate, second seed oriented plate, electromagnetic vibrator, adjustment door, seed cleaning brush, seed discharge wheel and other components. First seed oriented plate, vibration plate and second seed oriented plate combine to form the structure of the seed filling room with staggered oriented plates. The installation angle at which the seed oriented plates are mounted plays a crucial role in seed diversion.

The working principle of the device is that the rice seed forms a "Z-shaped" continuous seed flow in the filling area above the seed discharge wheel through the diversion effect of the three-layer staggered oriented structure, and at the same time, the funnel-shaped flow generated by the rice seeds during the seed supply process is alleviated under the action of the electromagnetic vibrator (Lu., 2018; Yan et al., 2020; Garg et al., 2018). Then the seeds are filled into the groove of the seed discharge wheel in the filling area, and reach the outlet with the rotation of the seed discharge wheel. The excess rice seeds are blocked within the outlet through the flexible seed cleaning brush under the adjustment door, then the rice seeds discharge box filled in the groove of the seed discharge wheel are realized under the continuous and stable rotation of the seed discharge wheel. The structural parameters of the seed filling room with staggered oriented plates directly affect the operational performance of the seed supply mechanism.

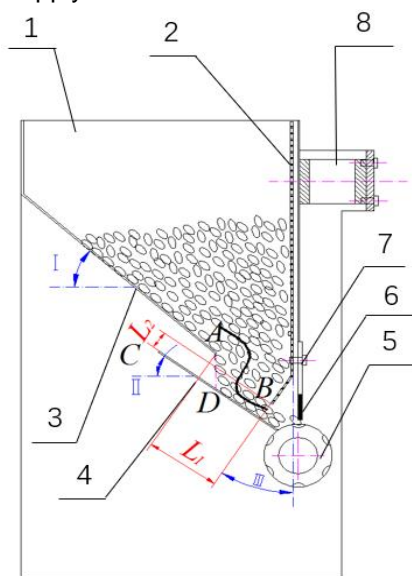

Fig. 1 - Structure diagram of quantitative seed feeding device

1 - Seed box; 2 - Electromagnetic vibration plate; 3 - First seed oriented plate; 4 - Second seed oriented plate;
5 - Seed row wheel; 6 - Cleaning brush; 7 - Adjusting door; 8 - Electromagnetic vibrator

The installation angle and clearance distance of seed oriented plate play an important role in seed diversion. As shown in Figure 1, the installation angle of the first seed oriented plate is I , and the clearance distance between it and the vibration plate of the seed box is L_1 ; The installation angle of the second seed oriented plate is II , and the clearance distance between it and the vibration plate of the seed box is L_2 . The lower inclination angle of vibration plate is III . According to the angle of repose of rice seeds and the friction coefficient (Wang., 2010) between seeds and the stainless steel plate (the selected material of the seed oriented plate), the inclination angle I was designed to be 45° . The inclination angle II is designed to be 37° , aiming at avoiding the excessive amount of seeds at the outlet port, and at the same time ensuring that the filling angle of the seed filling area can meet uniform and sufficient seeding of the row of seed wheels. The angle of inclination III needs to be greater than the angle of repose of the rice seeds and the static (sliding friction angle) between the seed oriented plate, so it is designed to be 45° .

Critical arching condition for rice seeds

In order to design the gap distance between the seed oriented plates, the motion characteristics of rice seeds in the seed filling room were analyzed with reference to the flow characteristics of the materials in the silo in the theory of silo unloading (Dou., 2023). The flow patterns of materials in the seed filling room are mainly divided into two types: overall flow and central flow (Sun., 2020; Ivan Kreft., 2023; Weng et al., 2023), and central flow is the main cause of the arching phenomenon. Therefore, the structure of the seed oriented plates should be designed to avoid central flow of rice seeds in the seed box as much as possible and promote the overall flow of seeds. For this reason, taking the position between the second seed oriented plate and the vibration plate of the seed box as an example, the critical limit arching state of the seed at this position is analyzed, as shown in Figure 2.

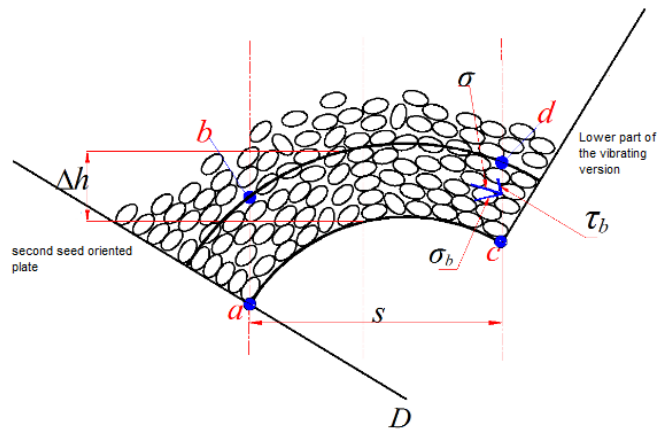

Fig. 2 - Situation of critical arch formed

Note: Create trajectory surfaces *ac* and *bd* on the knotted arch seed layer to describe the principal stresses in the knotted arch seed layer; Make vertical surfaces *ab* and *cd* upwards from points *a* and *c* perpendicular to the arched seed layer, and take the discrete unit cell *abcd*; Make the combined stress σ on the *cd* surface of the unit cell and decompose it into positive stress σ_b and tangential stress τ_b .

If *A* is the area of the long slit-type hole at the location of the arch between the seed oriented plates, *L* is the perimeter of the long slit-type hole, and the tangential stress τ_b on the *cd* surface is assumed to be approximately constant along the perimeter of the long slit-type hole (Deng et al., 2013), then for the stabilized arching seed layer, the force balance equations are:

$$A\Delta h\rho g = L\Delta h\tau_b \tag{1}$$

where:

Δh - the height of the discrete unit *abcd*, [mm]; ρ - rice seed density, [kg/m³]; *g* - acceleration of gravity, [m/s²].

It is assumed that all the position points around the long slot holes are in the limit equilibrium state, and the stress Mohr's circle can be obtained:

$$\tau_b = \tau_0(1 + \sin \phi) \tag{2}$$

where:

τ_0 - rice seed initial shear stress, [Pa]; ϕ - rice seed internal friction angle, [°].

For the seed box in this paper, the flow outlet section is rectangular, and the gap distance of the flow outlet is designed to be *S* (mm) and the length to be *l* (mm). According to Eq.1 and Eq.2, the gap of the flow outlet of this kind of box can be expressed as:

$$s = \frac{2\tau_0 l(1+\sin \phi)}{l\rho g - 2\tau_0(1+\sin \phi)} + d \tag{3}$$

where:

d - maximum size of rice seed, [mm].

Therefore, for the seed filling room with staggered oriented plates and vibration in this study, *L*₂ should satisfy:

$$L_2 > \frac{\tau_0(l-4-2d)(1+\sin\phi)+l\rho g(2+d)}{\sin 45^\circ [2l\rho g - 4\tau_0(1+\sin\phi)]} \tag{4}$$

Similarly, the above analytical method yields that L_1 should satisfy:

$$L_1 > \frac{\tau_0(l-4-2d)(1+\sin\varphi)+l\rho g(2+d)}{\sin 53^\circ [2l \log - 4\tau_0(1+\sin\varphi)]} \tag{5}$$

For the rice seeds, when the length of outlet hole l exceeds 600 mm, the critical arch gap S tends to be stable under the influence of outlet hole length l (Dou., 2023). Through the analysis of the above conditions, it is determined that L_1 is 36 mm and L_2 is 21 mm.

Discrete Element Simulation Parameter Design and Experimentations

The working process of the quantitative seed supply device was simulated and analyzed to determine if the design of seed filling room with staggered oriented plates and vibration meets the seed supply requirements of a vibratory flow type rice precision planter. The three-dimensional model of the quantitative seed supply device created by the EDEM software is shown in Figure 3, and the physical parameters and contact parameters (Zhan et al., 2015) of each material required for simulation are shown in Table 1. The rotation speed of the seeding wheel for hybrid rice seeds was set at 3.3 r/min, the simulation time was set at 30 s, and the movement type of the vibration plate of the seed box was sinusoidal translation with an amplitude of 0.015 mm and a frequency of 50 Hz. In order to fully study the flow state and distribution of rice seeds in different seed layer regions in the seed filling room, the rice seed particles in the seed filling room were stratified into 10 layers from the bottom to the top, as shown in Fig. 4.

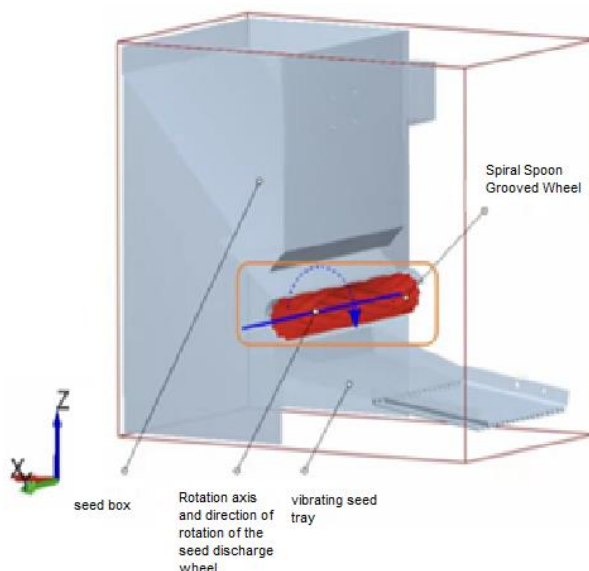

Fig. 3 - Discrete element model for quantitative seeding device

Table 1

Contact parameters between rice seeds and materials

Contact parameter	Numerical value
Rice seed and rice seed recovery coefficient	0.42
Static friction coefficient between rice seed and rice seed	0.354
Coefficient of rolling friction between rice and rice seed	0.016
Recovery coefficient of rice seed and stainless steel plate	0.52
Static friction coefficient between rice seed and stainless steel plate	0.52
Rolling friction coefficient between rice seed and stainless steel plate	0.01
Recovery coefficient of rice seed and nylon 1010 rod	0.5
Static friction coefficient between rice seed and nylon 1010 rod	0.5
Rolling friction coefficient between rice seed and nylon 1010 rod	0.02

Influence of electromagnetic vibration on the seed supply frequency

Under the same sowing condition, the vibration effect of the vibration plate was taken as the test factor, and two groups of seed supply process simulation tests were designed, one group was set with the vibration of the seed filling room, and the other group was set without the vibration.

The Settings of the remaining materials, contact parameters and motion parameters of the seeding wheel were the same, and the simulation time was 85 s (Figure 4). It can be seen from Fig. 4 that the area of the retention area generated by the vibration plate of the seed box with or without vibration is not much different, but the disconnection time of the seed layer with vibration is later than that when there is no vibration, and the vibration has a relieving effect on the "funnel flow".

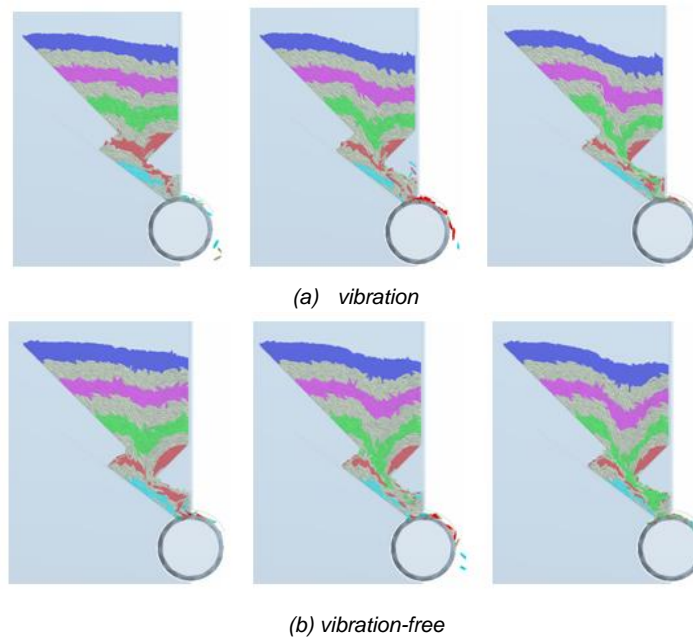
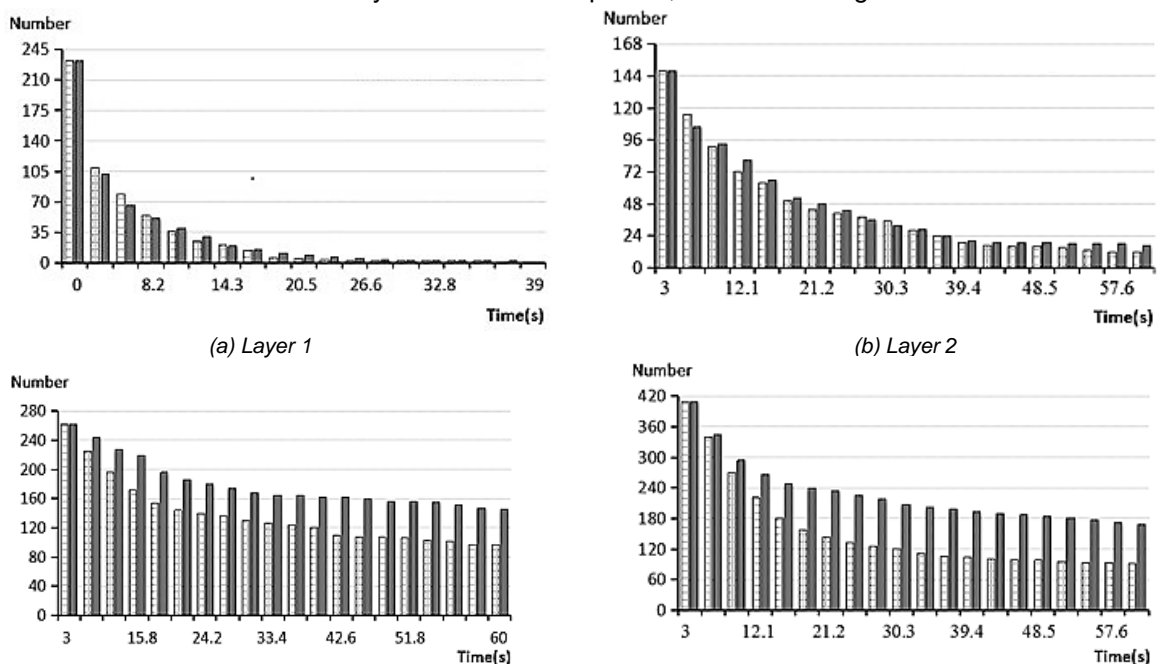

Fig. 4 - Cross diversion seed box seeding process at small sowing quality
 Note: Left, middle and right are simulation 10 s, 20 s and 30 s respectively

The variation of rice seed flow state in the seed filling room had a certain effect on the filling and discharging performance of the seed discharging wheel. As a second step, to further explore the role of the cross-conducting structure and the vibration effect on the seed flow state, the change in the number of rice seed particles in various layers was recorded according to the ten seed layers divided, and the change in the number of seeds within each seed layer over time was plotted, as shown in Fig. 5.



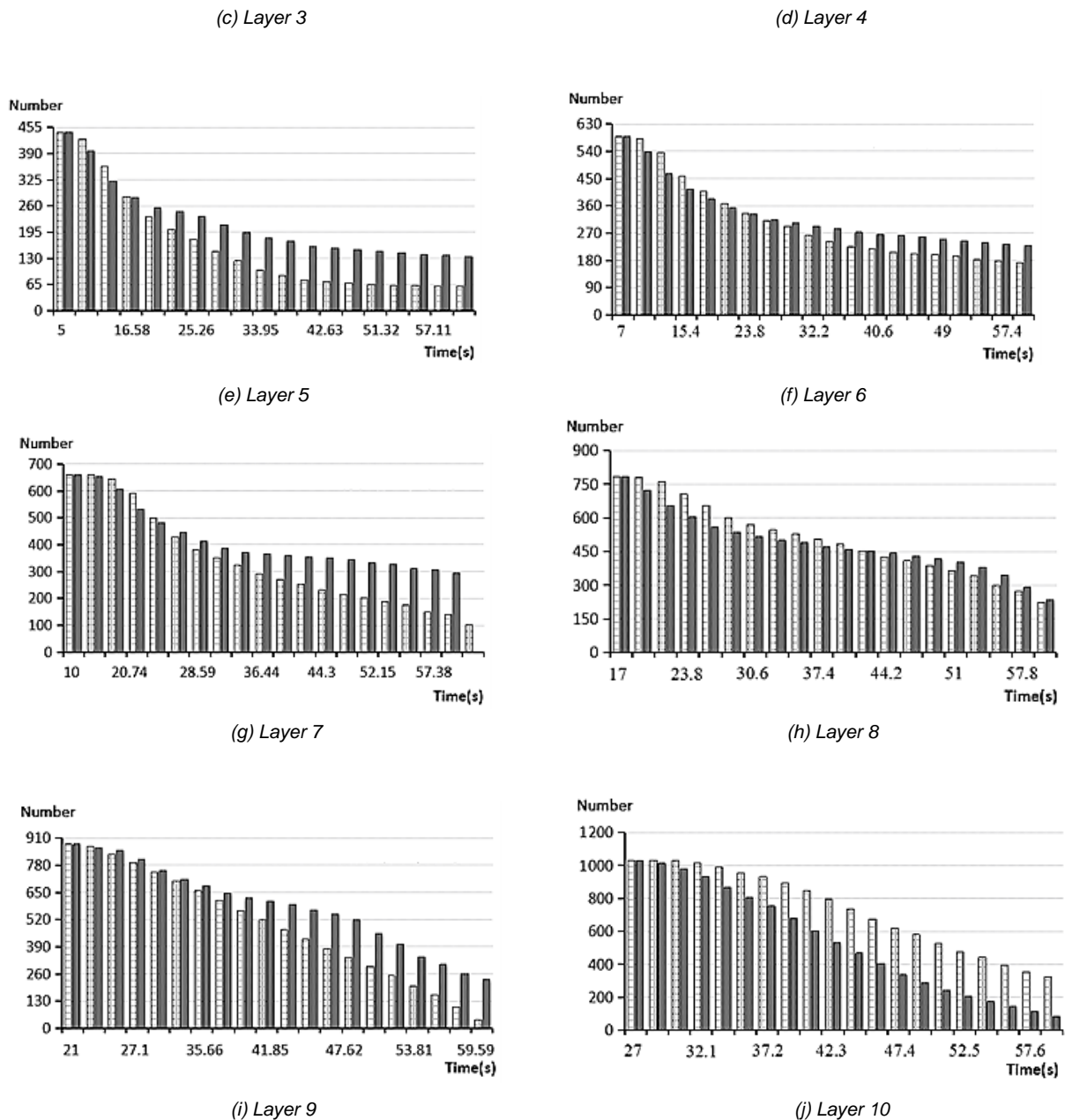

Fig. 5 - Quantity Change chart of seeds in different seed layers varies with time

Note: □ :vibration ■ :vibration-free

From Fig. 5 (a) (b) (f) (h), whether the vibration plate has vibration or not, it can be seen that the number of particles in the seed layer in the seed filling room is basically the same, indicating that the vibration does not have a significant role in influencing the time and rate of discharge of rice seeds from the 1st/2nd/6th/8th seed layer. It can be seen from Fig. 5 (c) (d) (e) (g) (i) that in the beginning, the number of rice seeds without vibration is basically the same as that with vibration, and the number of seed layers decreases faster in the subsequent vibration, indicating that the rate of rice seed discharge under vibration is higher than that without vibration.

Figure 5(j) shows the change in the number of rice seeds particles in the 10th seed layer, it can be seen the number of this layer decreases faster in the absence of vibration, which is due to the fact that with vibration this layer does not produce seed layer disconnection and the rice seeds are discharged later.

By analyzing the relationship between the number of rice seeds in various layers with time, it can be seen that the electromagnetic vibration effect increased the speed at which most of the seed layers were discharged. Further, the seed supply quality of the two sets of simulation tests was counted and the seed supply quality versus time curves were plotted for comparison in Fig. 6.

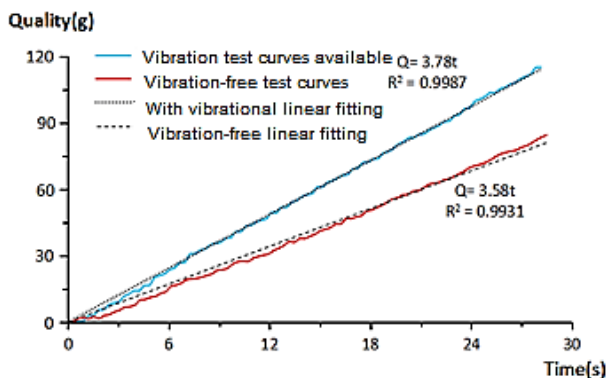

Fig. 6 - Feeding weight comparison chart of hybrid rice with or without vibration

By linear fitting of the two curves in Fig. 6, the fitted equation for the seed supply quality of the seed discharging wheel when the vibration plate of the seed filling room has vibration was obtained as:

$$Q_1 = 3.78t \tag{6}$$

where: Q_1 - quality of seed supply with vibration, [g]; t - supplying time, [s].

The linear fit above is $R^2_1 = 0.9987$. Seed feeding quality of seeding discharging wheel without vibration was obtained as:

$$Q_2 = 3.58t \tag{7}$$

where: Q_2 - quality of seed supply without vibration, [g].

The linear fit above is $R^2_2=0.9931$. The linear fit is close to 1 for both conditions. The linear fitting degree of seed supply under vibration is higher than that without vibration which indicates that the seed supply of spiral spoon groove wheel is stable with vibration action. The feeding frequency was 3.78 g/s with vibration and 3.58 g/s without vibration, indicating that electromagnetic vibration could increase the seeding frequency of hybrid rice by about 5.59%.

The same seed efficiency analysis was carried out for conventional rice varieties according to the above method. When the vibration plate of the seed filling room in the quantitative seed supply device has vibration, the seed supply frequency of the seed discharge wheel is 10.177 g/s, and the seed supply frequency is 9.851 g/s without vibration. The results showed that the electromagnetic vibration of the quantitative seed supply device promoted the seed supplying performance of the seed discharging wheel, increased the seed feeding frequency of the device by 3.31%. According to two sets of quantitative seed supply simulation tests, the same amount of rice seed was completely discharged faster with vibration than without vibration, indicating that the seed supply efficiency of the spiral spoon type grooved wheel is higher under vibration.

RESULTS

Test materials and methods

In order to verify the accuracy of the simulation analysis, the rice quantitative seed supply test was designed. The quantitative seed supply device developed was used in the test, as shown in Figure 7.



Fig. 7 - Quantitative-seed supply device

The rice varieties used were: the hybrid rice was Peiza Taifeng, the water content of rice seed was about 27.5%, the weight of 1,000 grains was 28.20 g, and the conventional rice was Huahang 38, the water content of rice seed was about 27.38%, the weight of 1,000 grains was 27.59 g.

The vibration effect of the vibration plate of the seed box was used as the test factor. The electromagnetic vibrator was turned on and adjusted to produce an amplitude of 0.015 mm on the vibration plate there was vibration, and turned off when there was no vibration. Quantitative comparative experiments on the seed supply of conventional rice and hybrid rice by the seed supply mechanism are conducted separately.

The variation coefficient of seed frequency of seed discharge wheel was used as the evaluation index of seed supplying stability of quantitative seed supplying device, and its statistical method was as follows: after stable operation of the mechanism, seed supply tests with and without vibration were carried out under the same sowing amount (Figure 8). The mass of rice seeds discharged from the seed discharge wheel in every 5 s was respectively obtained and weighed using an electronic scale with an accuracy of 0.01 g (Figure 9). Repeated the above operation 5 times and recorded, and then the coefficient of variation of seed discharge frequency was obtained.



Fig. 8 - Seed supply trials



Fig. 9 - Weighing seeds on electronic scales

The percentage increase of seed supply frequency with vibration compared with that without vibration under the same sowing quantity was used as the index to evaluate the increase of seed supply rate by vibration effect. The statistical method was as follows: The mass of rice seeds discharged by the rotation of the seed discharge wheel for 60 s was obtained, and then the average seed supply frequency of the seed discharge wheel was calculated. The test was repeated 6 times for each group to obtain the average value, and the increase rate of the seed discharge rate with vibration was calculated compared with that without vibration, as shown in Table 2.

Test results and analysis

Table 2

Feeding frequency comparison test result of quantitative-seeds supply device

	Regular rice planting		Hybrid rice supply	
	Have vibration	Vibration-free	Have vibration	Vibration-free
Frequency of seeding rotation / (g/s)	9.96	10.01	4.73	4.46
	9.67	9.92	4.35	4.38
	10.21	9.38	4.49	4.31
	9.89	9.83	4.66	4.02
	10.13	8.96	4.71	4.59
Average feeding frequency / (g/s)	9.97	9.62	4.59	4.35
Coefficient of variation / %	2.12	4.59	3.56	4.89
Vibration feed increase rate / %	3.64		5.52	

From the results of the frequency of seed supply in Table 2, the vibration effect can increase the seed supply frequency of the quantitative seed supply device by 3.64% in the case of conventional rice and 5.52% in the case of hybrid rice. Compared with the simulation results, the relative errors of the simulation are 9.07% and 2.00% respectively, indicating that the simulation results are highly accurate. Under the condition of vibration or not, the variation coefficient of seed frequency was lower than that of seed quantity, indicating that the rice seed quantity per unit time was more stable. The stability of conventional rice and hybrid rice could be improved by 2.47% and 1.33% after the vibration effect was added to the vibration plate of seed filling room, which indicated that the electromagnetic vibration effect of vibration plate of seed filling room had more obvious effect on the stability of conventional rice.

CONCLUSIONS

(1) The quantitative seed supply device adopts the structural design of staggered oriented plates and vibration seed filling room. Through the condition analysis, the gap distance between first oriented plate and second oriented plate and the vibration plate of the seed filling room respectively was determined.

(2) The working process of the seed supply device with and without vibration was simulated, and it was obtained that the electromagnetic vibration of the vibration plate could improve the frequency and stability of seed supply. It is verified that the cross-flow structure in the seed box makes the rice seeds form a "Z-shaped" continuous seed flow, which can provide a continuous and stable seed filling volume for the seed discharge wheel.

(3) The seed supply frequency test was conducted on the quantitative seed supply mechanism to verify the conclusions of the quantitative seed supply simulation analysis. Separate quantitative seed supply tests were conducted for small sowing weight of conventional rice and larger sowing weight of hybrid rice. The results showed that the electromagnetic vibration increased the seed supply frequency of conventional rice by 3.64% and that of hybrid rice by 5.52%. Analysis of the coefficient of variation of the seed supply frequency of the seed discharge wheel indicated that the vibration improved the stability of the seed supply device by 2.47% for conventional rice and by 1.33% for low seeding rates, increasing the stability of seed supply.

REFERENCES

- [1] Dou, J., (2023). Research on particle flow behavior and structural optimization in a hopper based on EDEM (基于 EDEM 的料斗内颗粒流动行为及其结构优化研究). *Wuhan University of Science and Technology*, Hubei/China.
- [2] Deng, W., Li, Z., Qiu, X., Wang, W., Wu, X., Zheng, D., (2013). The Research of Rice Liquidity and Arching Based on Crossed Diversion Seed-box (基于交叉导流式种箱的稻种流动性及结拱研究).

- Agricultural Mechanization Research*, Vol. 35, pp. 145-149, Heilongjiang/China.
- [3] Garg, V., Mallick, S., García-Trinanes, P., (2018). An investigation into the flowability of fine powders used in pharmaceutical industries. *Powder Technology*, Vol. 336, pp. 375-382, Switzerland.
- [4] Han, Q., Bing, X., Zhi, J., (2023). Study on influencing factors of hole-filling performance of rice precision direct seed-metering device with hole ejection. *Biosystems Engineering*, Vol. 233, pp. 76-92. United States.
- [5] Ivan, Kreft., Aleksandra, Golob., Mateja, Germ., (2023). A Crop of High Nutritional Quality and Health Maintenance Value: The Importance of Tartary Buckwheat Breeding. *Agriculture*, Vol. 13, pp. 17-83, Switzerland.
- [6] Jian, S., Yong, T., Hong, H., (2023). Molecular Breeding of Zheyong810, an Indica-Japonica Hybrid Rice Variety with Superior Quality and High Yield. *Agriculture*, Vol. 13, pp. 1807, Switzerland.
- [7] Li, Z., Zou, W., Zhang, P., (2021). Effect of Seeding Density and Method on Tillering Characteristics of Mechanical Transplanting in indica Rice (播种密度和方式对机插籼稻分蘖成穗的影响). *Journal of Nuclear Agronomy*, Vol. 35, pp. 722-736, Beijing/China.
- [8] Lu, F., (2018). Working mechanism analysis and experimental research on two-stage double vibration rice precision seeder (两级双振动式水稻精密播种器机理分析与试验研究). *South China Agricultural University*, Guangzhou/China.
- [9] Ma, X., Chen, L., Li, Z., (2023). Furrow opener for the precision drilling nursing seedlings of hybrid rice (杂交稻精密条播育秧底土开沟装置设计与试验). *Transactions of the Chinese Society of Agricultural Engineering*, Vol. 39, pp. 1-14, Beijing/China.
- [10] Sun, D., (2020). Study on Effects of Inserts in Hopper on Powder Discharge (料仓改流体对粉体下料影响的研究). *East China University of Science and Technology*, Shanghai/China.
- [11] Shan, S., (2022). Physiological Mechanisms for the High Yield in Double-Season Hybrid Rice Machine-Transplanted with Less Seedlings per Hill (少本密植机插双季杂交稻高产生理机制研究). *Hunan Agricultural University*, Hunan/China.
- [12] Song, W., Wan, Y., Zhou, B., (2023). Design and Experiment of combined cavity-type precision hole-drop seed-metering device for rice. *INMATEH Agricultural Engineering*, Vol. 71, pp. 25-43, Romania.
- [13] Tian, L., Ding, Z., Su, Z., (2022). Design and Experiment of rotary precision hill direct seed-metering device for rice. *INMATEH Agricultural Engineering*, Vol. 66, pp. 311-320, Romania.
- [14] Wen, C., Jin, H., Cai, Y., (2023). Current Situation and Future Development Direction of Soil Covering and Compacting Technology under Precision Seeding Conditions in China. *Applied Sciences*, Vol. 13, pp. 6586, United States.
- [15] Wang, C., (2010). Research of Theory and Experiment on Air Suction Cylinder Device for Tray Nursing Seedling of Super-Rice (气吸滚筒式超级稻育秧播种器的基本理论及试验研究). *Jilin University*, Jilin/China.
- [16] Weng, X., Tan, D., Wang, G., (2023). CFD Simulation and Optimization of the Leaf Collecting Mechanism for the Riding-Type Tea Plucking Machine. *Agriculture*, Vol. 13, pp. 946, Switzerland
- [17] Xia, Q., Zhang, W., Qi, B., (2023). Design and Experimental Study on a New Horizontal Rotary Precision Seed Metering Device for Hybrid Rice, *Agriculture*, Vol.13, pp.158, Switzerland.
- [18] Yan, B., Gao, N., Meng, Z., (2020). Design and test of a gravity-assisted vacuum seed-meter for maize. *IOP Conference Series Earth and Environmental Science*, Vol. 512, pp. 012-093, Great Britain.
- [19] Zhan, Z., Ya, F., Jian, J., (2015). Monitoring method of rice seeds mass in vibrating tray for vacuum-panel precision seeder. *Computers and Electronics in Agriculture*, Vol. 114, pp. 25-31, Great Britain.