

DESIGN AND EXPERIMENT OF SELF-PROPELLED HIGHLAND BARLEY HARVESTING AND BINDING MACHINE

自走式青稞收割打捆一体机的设计与试验

Chengyi ZHONG^{1,2)}, Wenqing YIN¹⁾, Dejiang LIU^{2*)}, Keheng YAO²⁾, Wei CHEN²⁾, Zitao XING³⁾, Fan Jin²⁾

¹⁾ College of Engineering, Nanjing Agricultural University, Nanjing 210014, China

²⁾ Nanjing Institute of Agriculture Mechanization, Ministry of Agriculture and Rural Affairs, Nanjing 210014, China

³⁾ Ministry of Agriculture and Rural Agricultural Mechanization station, Beijing 100125, China

Tel: +86 025-84346278; E-mail: zhongchengyi@caas.cn

DOI: <https://doi.org/10.35633/inmateh-70-41>

Keywords: highland barley harvest, cutting device, bundling, field experiment

ABSTRACT

In view of the complex agronomic technology of highland barley production and the lack of special machinery for harvesting and bundling highland barley, the harvesting of highland barley is basically done manually. There is a seriously reduced degree of mechanization of highland barley harvesting. Therefore, this paper designs a self-propelled highland barley harvesting and bundling machine, which realizes a single operation process to complete mechanized complex operations such as harvesting, bundling and laying highland barley. By designing the highland barley harvesting method and cutting platform, the height of the cutting platform can be adjusted stepless, and the highland barley bundle knoter is designed to realize the regulation and control of the baling diameter of the highland barley. According to the design of the rope feeding mechanism, the gathering mechanism and the baling mechanism, the main parameters of the baling device are determined. The stubble cutting height of the machine is 325 mm, the average diameter of the highland barley bundles is 195 mm, the average weight per bundle is 5.08 kg, bale formation rate is 97.8%, the qualification rate of the straw bundle reaches 95.6%, drop resistance rate is 92.6%, operating efficiency is 0.82 ha/h. The harvest baler runs in low speed 1 gear, the machine has high operation efficiency, high bundling rate of highland barley, good paving effect, reduced labor intensity, provides the mechanized efficiency of highland barley harvesting. Fuel consumption per hectare is 8.05 kg·hm⁻², and the three shifts are without fault, to sum up, it can meet the requirements of highland barley harvesting and baling. The above research can provide a reference basis for the design of the highland barley harvesting baler.

摘要

针对青稞生产农艺技术复杂且青稞收割打捆无专用机械，目前青稞收获基本靠人工背负式收割器割倒青稞后，人工打捆后用拖拉机拉到场地上晾晒，劳动强度非常大，且效率低下，严重降低了青稞收获的机械化作业程度。因此本文设计了自走式青稞收割打捆一体机，该机具实现了一个作业流程即可完成青稞收割、打捆、铺放等机械化复式作业。该机具通过设计青稞收割方式和割台，可无级调整割台高度，设计了青稞成捆打结器，实现了对青稞打捆捆径的调节控制，通过对送绳机构、集禾机构、放捆机构进行设计，确定了打捆装置的主要参数。该机作业后的割茬高度 325mm，青稞捆平均直径为 195mm，每捆平均重量为 5.08 kg，成捆率 97.8%，草捆合格率达到 95.6%，草捆抗摔率 92.6%，作业效率 0.82 公顷/小时，收割打捆机行驶速度挂在低速 1 挡，该机具作业效率高，青稞成捆率高，铺放效果好，降低了劳动强度，提供了青稞收获的机械化效率，每公顷燃油消耗量 8.05kg·hm⁻²，并且三班次作业无故障，综上，可满足青稞收割打捆一体化机械作业需求，以上研究可为青稞收割打捆机的设计提供参考依据。

INTRODUCTION

Highland barley is an annual herb of the gramineae family and the barley family. It is erect, smooth and up to 100 cm tall. It is the main food, fuel and livestock feed for the inhabitants of Tibetan areas in China, and it is also the raw material for the production of beer, medicine and health products. Agricultural mechanization is an important basis for changing the mode of agricultural development and improving rural productivity, as well as an important symbol and inevitable way of agricultural and rural modernization. In 2021, the highland barley planting area is 2.163 million mu, and the output exceeds 825,000 tons (Dai F, 2019). Highland barley has been planted in Tibet, China for many years, the planting agronomy is complicated, the agricultural machinery research and development investment is small, and there are many problems in mechanized harvesting.

First, the wheat combine harvester introduced in the mainland cannot meet the technical needs of highland barley mechanization harvesting in our area. Highland barley needs to go through a period of time after harvesting (Dai Fei, 2021), in order for the grain to be fuller, easier to eat, of better quality. This characteristic of plateau barley led to the introduction of wheat combine harvesters from the mainland, which could not mechanize the harvest of plateau barley (Jiang Chunyan, 2010). At present, the farmers and herdsmen in Tibet in the highland barley harvesting operation, basically use the piggyback harvester. After dragging the field with a tractor for a period of time, the threshing, harvesting or collection of wheat combine harvesters are completed manually or by small machinery, which greatly reduces the efficiency of mechanized harvesting and seriously limits the level of mechanized barley harvesting. With the problems of "difficult labor" and "expensive labor" in agriculture intensifying year by year (Li H.C., 2012), the traditional planting methods of low efficiency and high labor cost input make the comparative benefits of highland barley production continue to decline, and the research, development and improvement of new efficient highland barley mechanized harvesting technology and equipment are imminent (Liu Kai, 2020).

At present, there are few researches on highland barley processing technology and mechanized production equipment in various countries. This project is mainly based on the existing mechanized harvesting equipment for rice and wheat and according to the highland barley special agronomic technology and mechanized production it is necessary to carry out technological innovation, research and development of highland barley special harvesting equipment (Liu Kai, 2020). From the formulation of technical regulations for mechanized barley harvesting, the research and development of mechanized packaging equipment and the research and development of mechanized mining and stripping equipment, the status quo and expected analysis of existing technologies, intellectual property rights and technical standards at home and abroad are analyzed.

The research and development of foreign harvesting and baling equipment began in the 1920s, and the German CLAAS company began to study the bundling machine knotter in 1927, and used it with the company's first cutting and binding machine. The popularization and use of the knotter has also further promoted the research and development of straw cutting and binding machine. In order to meet the production needs of straw transportation and mechanical unbaling, the technology of baling has been continuously developed in the aspects of baling density uniformity, rope tightness and knot performance stability. At present, AGCO (AGCO), New Holland (New Holland), Krone and other world's top agricultural machinery equipment manufacturing companies, in the field of straw baling and harvesting technology patent quantity and quality are in the world's leading position. Domestic baling equipment research and development began in the 1960s, because the market demand is not large, there are not many research results. In recent years, with the government's attention to the environmental pollution caused by straw incineration and the increasing utilization value of straw resources, more and more scientific research institutions and agricultural machinery enterprises began to deeply study the straw bundling mechanism and achieved certain scientific research results (Qiang Xiaolin, 2008). The Nanjing Institute of Agricultural Machinery of the Ministry of Agriculture and Rural Affairs, the China Agricultural Machinery Institute and Shandong Leiwo and other scientific research institutes and agricultural machinery enterprises in rice and wheat and other bulk crops pick up institutions, feeding institutions, baling rooms, bundling systems and so on have more research results. For highland barley and other small grains baling and baling equipment the research is still in the initial stage, because the highland barley straw is all used as feed in the grazing area, in order to facilitate transportation and storage, the height of cutting stubble, the affordability of the rope, the tightness of the bale, the loss of ear head to special needs, highland barley mechanized baling equipment research and development results will be more and more numerous (Peam Ba, 2015).

Based on the above research and development, the Nanjing Institute of Agricultural Mechanization of the Ministry of Agriculture and Rural Affairs and Xizang Huacheng Industrial Co., Ltd. established a research and development team to conduct in-depth investigation and research, and through repeated comparison and demonstration, extensively collected information and materials of similar products in China and abroad, digested and absorbed advanced technologies. According to the current Chinese research, the mechanical structure of rice and wheat combine harvester and baler has basically the same characteristics (Tian Bin, 2021), aiming at the agricultural requirements of highland barley, the self-supporting highland barley harvesting and binding machine is developed. The machine can complete one operation process to complete the highland barley harvesting, baling, laying and other processes, mechanical efficient cutting and drying, baling and field placement. According to the preliminary calculation of the technical parameters of the machine, the machine can improve the operation efficiency by 50% ~ 60% compared with the traditional artificial harvesting highland barley, each machine can replace 20-25 labor force, and the work efficiency can be increased by 15 ~ 20 times.

MATERIALS AND METHODS

Whole structure and working principle - Whole structure

4 KL-1200 highland barley harvesting and binding machine is mainly composed of rack, cutter, knot cutter, rope feeder, baling mechanism, transmission system, walking mechanism and so on, as shown in Figure 1. The frame part is composed of a front gearbox and a rear drive box. The front gearbox is designed to advance third, second, first and reverse gears. The countershaft of the front transmission serves as the power input for the rear drive (Geert Craessaerts, 2009; Wang Baoai, 2021). The whole machine is rear-wheel drive, front-wheel steering. The front gearbox and the rear drive box are divided into upper and lower layers, and special connecting parts are designed to connect them. The folding steering rotation center is designed at a suitable position between the front gearbox and the rear drive box. The steering mechanism of the five Signs agricultural vehicle, the ball head pull rod and the steering wheel are selected as the bending steering mechanism. Total frame length: 1586 mm, total frame width: 718 mm, total frame height: 1227 mm.



Fig. 1 – Overall highland barley harvesting and binding machine



Fig. 2 – Appearance

For operation, as shown in Figure 3, the highland barley stalk is cut down by the cutting mechanism of the binding machine, it is transported from the right side of the cutting platform to the left side through the picking teeth of the conveyor chain, and enters the baling device. The driving wheel of the baling device continuously rotates, and the highland barley rod transported by the picking teeth is transferred to the baling mechanism through the collecting and compression mechanism, and the retaining rake is continuously squeezed (Wang Bao'ai, 2020). When the accumulated highland barley rod reaches a certain amount. The stop pull rod of the baling mechanism is removed to complete a baling cut, and then the above work content is repeated to enter the next working cycle. The binding machine can complete the cutting of highland barley stalk and the baling of highland barley stalk in one workflow. When working, the parts operate flexibly, and the rotating parts have safety tips and protective covers. The baling effect of highland barley harvesting is shown in Figure 4. The main parameters of the highland barley harvesting and binding machine are shown in Table 1.



Fig. 3 – Field operation



Fig.4 - Highland barley harvesting and baling effect

Planting agronomic qualification

Table 1

Highland barley harvesting and binding machine technical parameter table

No.	Project	Technical parameters
1	Version	4KL-1200
2	Type of power	Single cylinder diesel
3	Tractor power (kW)	25.7
4	Cut width (tunable, mm)	1200
5	Harvesting line number	4
6	The harvesting way	Cutting type
7	Number of cutting knives (put)	8
8	Cutting knife width (mm)	90
9	Cutting knife length: (mm)	2200
10	Outline dimensions length x width x height: (cm)	1586 x 718 x 1227
11	Operation speed (km·h)	3.5
12	Machine weight/kg	~ 1200 kg
13	Number of operators (including tractor driver)	1
14	Block digits	4

Design analysis of key highland barley harvesting and binding machine**Design of whole structure**

The overall arrangement of the machine is "soil" type structure, as shown in Figure 5 below. The cutting table, driving seat, binding conveyor, feeding mechanism, compression device and diesel engine are all symmetrically arranged along the longitudinal axis of the main engine, and the load balance of the left and right walking wheels is balanced (Mekonnen Gebreslasie, 2010; Wang Baoai, 2018). In the process of operation, the highland barley stalk material flows along the vertical direction of the binding machine, reducing the resistance of picking and feeding, making the highland barley material flow smooth and continuous, reducing the harvesting loss rate, enhancing the highland barley bundling rate, and ensuring the mechanized productivity and operation quality of the highland barley harvesting and bundling machine.

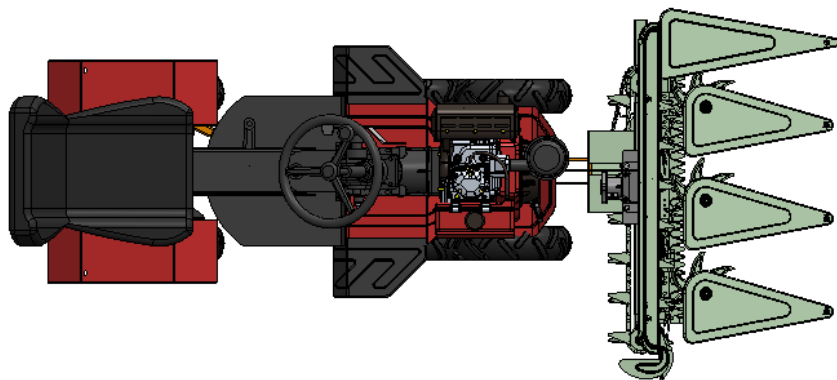

Fig. 5 - Layout diagram of highland barley harvesting and binding machine

The highland barley cutting table is arranged in front of the machine, close to the driving wheel driven by the diesel engine, which shortens the total length of the unit and improves the shape copying effect of the cutting table (Hermann D., 2016; Yang Wenmin, 2019). The steering wheel and 192FE single cylinder diesel engine are located in the middle of the machine, and the driving seat is located behind the machine, which facilitates the driving of the harvest baling operation and also facilitates the later maintenance. The cutting table, cutting knife, binding conveying device, feeding mechanism, compression device, etc. are arranged in the front of the machine and installed on the front frame.

Design of walking chassis and walking system of highland barley harvesting and binding machine

The chassis frame is the supporting part of the equipment, which carries all the component parts, as well as the assembly and connection positions between the parts. The highland barley harvesting and binding machine uses a single cylinder diesel engine to drive the front wheel drive, frame articulated shaft connects the front and rear frame together, two steering cylinders are installed on the left and right sides of the frame articulated shaft (Yong-Joo Kim, 2013), the driver rotates the steering wheel, the steering cylinder begins to work.

Under the action of the steering cylinder, the hinged shaft of the rear frame rotates to drive the subsequent steering, so as to realize the steering of the entire integrated machine. The chassis and walking system of the machine are shown in Figure 6 below.

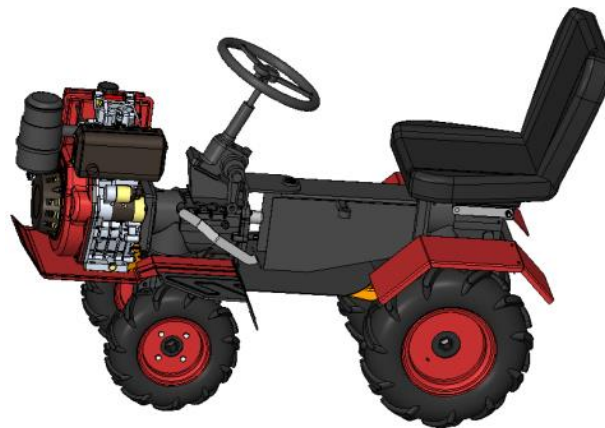

Fig. 6 - Highland barley harvesting baler walking chassis 3 D general map

The driving power of the machine is 192FE single-cylinder diesel engine, which transmits the power to the driving wheel through the driving wheel bridge, which is rigidly fixed on the tube beam of the driving bridge, and is composed of the clutch, gearbox, central transmission, differential and brake. The drive wheel bridge is equipped with 4 gears and stepless gear components, each of which realizes stepless transmission by moving the gear handle to adjust the driving and working speed to meet the needs of harvesting highland barley in the field (Zhang Shilin, 2020).

The power required for the operation of the machine is related to the weight of the baler, the operation speed of the baler and the soil condition. The calculation formula can be obtained by consulting the relevant information as follows:

$$P_v = \frac{G \cdot v \cdot f}{\tau} \times 10^{-3} \quad (1)$$

where: G - represents the total weight of the machine, N;

P_v - power required for machine operation, kW;

v - machine operating speed, m/s;

f - the dynamic friction resistance coefficient of the wheel driving is 0.35;

τ - the driving efficiency coefficient of the traveling system is 0.95.

It can be seen from equation 1 that the power required by the machine to travel is positively correlated with the traveling speed. Therefore, it should be calculated according to the highest forward speed during the operation of the machine and the maximum $v=5.5 \text{ km/h}=1.53 \text{ m/s}$. The transmission efficiency coefficient of the traveling system is 0.95. According to the calculation, the total weight of the machine in full load operation is $m=1200 \text{ kg}$, $G=mg=5880 \text{ N}$. Bring into the above equation 1 to obtain, the power required by the walking system during machine operation is $P_v=6.63 \text{ kW}$.

Design of the highland barley cutting device

Harvester cutter is divided into reciprocating cutter, rotary cutter. Rotary cutting speed is relatively high, cutting ability is strong, but not suitable for wide operation, more used in lawn mowers, harvesting machinery widely used reciprocating cutter, reciprocating cutter by moving blade, knife rod, fixed blade, blade press, gasket, upper and lower friction pieces and other parts of the composition, as shown in Figure 7. The advantages of reciprocating cutter is stable cutting performance. The highland barley binding machine cutting device designed in this paper is a reciprocating cutter, and the cutting mechanism is composed of a cutter and a cutting tool transmission device (Streicher E.A., 2007; Zhang Shilin, 2020). The function of the cutting mechanism is to cut off crop stalks for cutting width 0.5~5 m. The cutting width designed in this paper is 1.2 m, and the average cutting speed is less than 2.5 m/s. The cutting mechanism performs low and neat cutting, there is no leakage cutting phenomenon, small power consumption, small vibration, easy maintenance and wide adaptability.

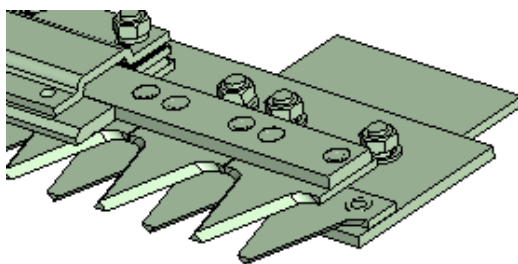

Fig. 7 – Harvesting baler cutter

Speed and forward speed of the cutter

The cutting process of harvesting machinery is the synthesis of cutting motion and the advancing speed of the machine, and the advance distance is the time for the cutting tool to complete a stroke, which can be expressed as the relationship between the cutting tool speed and the advancing speed, expressed as follows:

$$L = V_1 \frac{\pi}{\omega} \quad (2)$$

where:

L - the time for the cutter to complete a stroke the distance for the machine to advance, m;

V_1 - tool forward speed, m/s;

ω - cutter speed, rad;

The ratio of the average cutting speed to the forward speed is the cutting speed ratio:

$$\frac{v_{average}}{v_1} = \frac{sn/30}{Hn/30} = \frac{S}{H} \quad (3)$$

where:

$v_{average}$ - average speed of the cutter, m/s;

v_1 - tool forward speed, m/s;

S - cutter stroke, mm;

H - cutter drive, mm;

n - cutter shaft speed, rad/min;

ω - Cutter axis angular speed, rad.

In the process of harvesting and baling highland barley, too small cutting speed ratio will cause the highland barley stalk to break, resulting in unequal cutting height, and too large cutting speed ratio is easy to cause leakage, reduce harvesting efficiency, and increase the wear of the cutter. The relevant literature tests show that when the cutting speed ratio is between 0.85 and 3.5 (Zhang Shilin, 2020), the quality of the highland barley is better, so that the rotating speed of the cutting cutter is determined to be 450 r/min.

Field experiment and data analysis

Test site and equipment

In August 2022, the highland barley harvesting and binding machine prototype test was carried out in Zhangba Village, Baiba Town, Bayi District, Nyingchi City. The barley used in the test was highland barley, and the varieties of highland barley planted are Zangqing 2000, with an average plant height of 1100 mm. The tying rope used in the knotter was a special nylon bundling rope for the bundling machine, and the speed of the speed regulating motor was set at 450 r/min. The highland barley after harvesting was bundled and pushed to the left side of the bundling machine, and was spread on the ground. Stop to measure bale diameter and weight and related performance indicators.

Test instruments and equipment

Stopwatch, leather tape, steel tape, steel tape and post are used in the test, which can meet the test requirements.

Test time and place

The prototype was tested on August 5, 2022. The test site was conducted in the field of Zhangba Village, Baiba Town, Bayi District, Nyingchi City, China. The test plot was flat with a length of 900 m and a width of 800 m. The weather was fine on the day of the test, which could meet the test requirements.

RESULTS

Test items and test results

In order to understand and master whether the prototype can meet the design requirements and technical performance indexes, the barley bale diameter, stubble height, bale rate, bale pass rate, bale fall resistance rate, fuel consumption per hectare and operation efficiency were tested. The measurement results are shown in Table 2.

Table 2

Test result of miniature ridge mulcher

No.	Project	Agronomic and technical requirements	Determination results	Determinant
1	Binding rate (%)	≥80	97.8	qualified
2	Barley bale qualified rate (%)	≥75	100	qualified
3	Drop resistance of bale (%)	≥70	92.6	qualified
4	Barley bale diameter (mm)	100-300	195	qualified
5	Highland barley stubble height (mm)	300-500	325	qualified
6	Working performance (hm ² /h)	0.82		
7	Fuel consumption per hectare (kg·hm ⁻²)	8.05		
8	Fault situation	Three shift operation without fault	meet the requirement	qualified

Through the field test, the main performance index of the machine meets the design requirements, and can meet the agronomic requirements of highland barley harvesting and binding.

CONCLUSIONS

(1) The working parts of the highland barley harvesting and bundling machine designed in this paper are arranged in the front of the self-propelled highland barley harvesting and bundling machine, which is mainly composed of a frame, a cutter, a knotter, a rope feeding mechanism, a baling mechanism, a transmission system, and a walking mechanism. The highland barley harvesting and bundling function completes the highland barley harvesting, bundling, laying and other mechanized compound operations at one time. The average diameter of the highland barley bundle is 195 mm, the average weight is 5.08 kg, and the bundling rate is 97.8%.

(2) The highland barley harvesting and binding machine will cut the highland barley into bundles in the post-ripening period and transfer it out of the field in a timely manner, this way it can be harvested 10-15 days in advance. Compared with the highland barley picking threshing machine, the highland barley harvesting and binding machine will bale the highland barley before the maturity period, avoiding the loss of the barley dropping. Compared with the highland barley combine harvester, barley cutting and bundling machines will simplify the labor intensity of traditional hand harvesting. However, after the barley matures, in order to ensure the quality of the barley and increase the yield, the barley stem can also be used as livestock feed.

(3) The cutting width of the highland barley harvester designed in this paper is 1.2 m, the total transverse size of the machine is 1.58 m, the stubble height after operation is 325 mm, the baling rate of highland barley bales is 97.8%, the pass rate of straw bales is 95.6%, the fall resistance rate of straw bales is 92.6%, and the working efficiency is 0.82 ha/h. Fuel consumption per hectare is 8.05 kg·hm⁻², three shifts without failure. According to the summary, the designed highland barley harvesting and bundling machine meets the agronomic requirements of highland barley harvesting in sections.

ACKNOWLEDGEMENT

This research was supported by Tibet Autonomous Region Science and technology plan project - highland barley mechanized low-loss harvesting equipment research and development and improvement (XZ202201YD0016C), the Science and Technology plan project of Tibet Autonomous Region - Research and development and application of equipment for key links of highland barley mechanized production (XZ202301ZY0015N-1), the National technical system of barley and highland barley industry (CRAS-05-04A-01).

REFERENCES

- [1] Dai F., Song X.F., Zhao W.Y. (2019). Motion simulation and test on threshed grains in tapered threshing and transmission device for plot wheat breeding based on CFD – DEM. *International Journal of Agricultural and Biological Engineering*, 12(1), pp.66-73.
- [2] Dai Fei, Zhang Shilin, Zhao Wuyun, (2021). Parameter optimization and test of self-propelled highland barley combined harvesting and binding machine (自走式青稞联合收获打捆一体机参数优化与试验). *Agricultural Research in arid Areas*, 39 (06), pp. 248-256.
- [3] Hermann D., Bilde M.L., Andersen N.A., Ravn O., (2016). A Framework for Semi-Automated Generation of a Virtual Combine Harvester. *IFAC PapersOnLine*, 13(4), pp. 11-19.
- [4] Streicher E.A., Stroshine R.L., Krutz G.W., Hinkle C.N. (2007). Cleaning Shoe Air Velocities in Combine Harvesting of Wheat. *Transactions of the ASAE*, 15(1), pp.211-220.
- [5] Geert Craessaerts, Josse de Baerdemaeker, Bart Missotten, Wouter Saeys, (2009). Fuzzy control of the cleaning process on a combine harvester. *Biosystems Engineering*, 68(3), pp.15-22.
- [6] Jiang Chunyan, Tan Jin, (2010). Research progress and application status of highland barley (青稞的研究进展及应用现状). *Xizang Science and Technology*, 2010 (02), pp. 14-16.
- [7] Li H.C., Li Y.W., Gao F., (2012). CFD-DEM simulation of material motion in air-and-screen cleaning device. *Computers and Electronics in Agriculture*, 88(2), pp. 111-119.
- [8] Liu Kai, Cui Qingliang, Hou Huaming, (2020). Selection test of highland barley crop threshing materials (青稞作物脱粒物料清选试验). *Agricultural Engineering*, 10 (09), pp. 71-76.
- [9] Liu Kai, (2020). Experimental study on the clearance characteristics of highland barley mechanical harvest effluent (青稞机械收获脱出物清选特性试验研究). *Shanxi Agricultural University*.
- [10] Mekonnen Gebreslasie, Josse De., (2010). Numerical and experimental study of a cross-flow fan for combine cleaning shoes. *Martine Baelmans. Biosystems Engineering*, 45 (01): 26-38.
- [11] Qiang Xiaolin, Chi Deshao, Feng Jilin. (2008). Highland barley production and development status in the Qinghai-Tibet Plateau region (青藏高原区域青稞生产与发展现状). *Xizang Science and Technology*, 2008 (3), pp.11-17.
- [12] Peam Ba, (2015). Discussion on the status quo and countermeasures of highland barley mechanized production. *Xizang Agricultural Science and Technology*, 37 (02): 46-48.
- [13] Tian Bin, (2021). Self-propelled crawler highland barley combined harvesting and binding machine. Gansu Province (自走式履带青稞联合收获打捆一体机), *Gansu Agricultural University*.
- [14] Wang Baoai, Zhang Qin, Ding Xiaobin, (2021). Current status and existing problems of highland barley mechanized harvesting (青稞机械化收获现状及存在问题). *Guangdong Silkulture*, 55 (01), pp. 57-58.
- [15] Wang Bao'ai, Dai Fei, Xin Shanglong, (2020). Test and analysis of the cutting force of highland barley stalk at mature stage (成熟期青稞茎秆切割力的测试与分析). *Journal of Gansu Agricultural University*, 55 (02), pp.201-208.
- [16] Wang Baoai, Zhang Qin, Xin Shanglong, (2018). Structural design of key components of the harvest stage (青稞穗茎分流双层收获割台关键部件的结构设计). *Mechanical Research and Application*, 31(03), pp.108-110.
- [17] Yang Wenmin, He Ming, Wu Bei, (2019). Design and test of rape cutter baling parts (油菜割捆机打捆部件的设计与试验). *China Agriculture Bulletin*, 35 (31), pp. 129-133.
- [18] Yong-Joo Kim, Sun-Ok Chung, Chang-Hyum Choi. (2013). Effects of gear selection of an agricultural tractor on transmission and PTO load during rotary tillage. *Soil & Tillage research*, 134, pp. 90-96.
- [19] Zhang Shilin, Dai Fei, Zhao Wuyun, (2020). Design and test of threshing device of highland barley combined harvester (青稞联合收获机脱粒碎芒装置设计与试验). *China Agricultural Machinery Chemical News*, 41 (11), pp.18-25.
- [20] Zhang Shilin, Dai Fei, Zhao Wuyun, (2020). Design and test of straw baling device for highland barley combine harvester (青稞联合收获机配套秸秆打捆装置设计与试验). *Zhejiang Journal of Agriculture*, 32 (07), pp. 1289-1301.
- [21] Zhang Shilin, (2020). Design and test of highland barley combined harvesting and binding machine (青稞收割打包机的设计与试验). *Gansu Agricultural University*.