

DESIGN AND TEST OF KEY COMPONENTS OF BIOCHAR RETURN MACHINE BASED ON ROCKY

基于 Rocky 的生物炭还田机关键部件设计与试验

Dezhi REN ^{1,2,3}, Luji ZHANG ², Wanyuan HUANG ² Huiting CHENG ², Tian'yi HE ^{1,3} Jun MENG ^{*1,3},

¹ Agronomy College of Shenyang Agricultural University, Shenyang 110866, China

² Engineering College of Shenyang Agricultural University, Shenyang 110866, China

³ Key Laboratory of Biochar and Soil Improvement, Ministry of Agriculture and Rural Affairs, P. R. China, Shenyang 110866, China

Tel: +86 15309898525; E-mail: mengjun1217@syau.edu.cn

DOI: <https://doi.org/10.35633/inmateh-68-60>

Keywords: Biochar return, Key component design, Rocky, Simulation analysis

ABSTRACT

To realize the integrated technology of biochar return to the soil, the key components of the biochar discharge system applicable to the biochar return machine were designed, and the force analysis of the return shovel was carried out to obtain the main working parameters affecting the effect of biochar return. Single factor and multi factor simulation tests were conducted with the coefficient of variation of biochar content uniformity as evaluation indexes, and outlet distance, conduit diameter, baffle angle as influencing factors. The data were processed and parameters were optimized using Design-Expert, and the results were optimized and experimentally verified. The validation results showed that the optimal parameters obtained from the simulation data could obtain the best results of biochar return to the field. Therefore, the procedures of this study can be used for the integrated technology of biochar return.

摘要

为实现生物炭还田一体化技术, 设计了适用于生物炭还田机上的排炭系统关键部件, 并对还田铲进行了受力分析, 得到影响生物炭还田效果的主要工作参数。单因素和多因素的仿真试验将炭量均匀性变异系数作为评价指标, 将出口距离、导管直径和挡板夹角作为影响因素, 利用 Design-Expert 处理数据并优化参数, 优化结果并试验验证。实验结果显示, 炭量均匀性变异系数与模型的模拟数据有很好的 consistency。因此, 本研究的程序可用于生物炭还田一体化技术。

INTRODUCTION

Biochar return is an important way of comprehensive utilization of straw (Zhang, et al., 2019; Liu, et al., 2018; Wei, et al., 2021). The current method of returning biochar to the soil is to spread the biochar on the surface of the soil and then mix the biochar with the soil using a rototiller, which is extremely labor-intensive and does not allow the biochar to mix evenly with the soil, making the return effect poor (Cheng, et al., 2016). The development of simulation technology has greatly reduced the cost of mechanical design. Discrete Element Method (DEM) is a numerical technique for predicting the behavior of bulk solids; it can help shorten (and improve) the design processes for agricultural machinery and their components. Discrete Element Models have been widely used in agriculture, for example, to simulate the working process of agricultural machinery, to predict the wear of machine components, to optimize structural parameters, etc. Therefore, an agricultural machine dedicated to biochar return to the field is designed to improve the efficiency and effectiveness of biochar return to the field using the DEM, and to provide a reference for industrialized equipment for biochar return.

Most of the current research on biochar return is to investigate the effect of mixing biochar and soil on the soil and the growth of various crops, but there is little research on how to return and how to improve the return effect. In the field of agricultural engineering, similar to biochar return technology, there are deep loosening and fertilizing technology and no-till seeding technology. Liu Lijing et al. designed a kind of full-layer fertilization shovel for corn subsoiling and simulated the working process of the shovel by EDEM (Liu, et al., 2021).

Zhao Shuhong et al. designed an interactive layered subsoiler based on discrete element simulation of the action of deep loosening shovel on soil (Zhao, et al., 2021). According to the agronomic requirements of straw fertilization, Liu Zhongze et al. designed a straw deep burying and returning machine, which can be used for straw fertilization, mulching, ridge beating and soil breaking (Liu, et al., 2021). Hu Hong et al., in order to solve the blocking problem in rice-wheat cropping system in the middle and lower reaches of the Yangtze River region, developed a broad width and precision minimal-tillage wheat planter (Hu, et al., 2016). Sukhbir Singh et al. studied the effect of different types of openers at different depths and speeds on soil penetration resistance, ridge height, specific draft, soil disturbance and germination rate (Sukhbir Singh, et al., 2017). Yang Qinglu et al. designed a corn layered fertilization device analyzed its working process by using the discrete element method (Yang, et al., 2020). Wang Chaoqun et al. designed a no-tillage planter with smashing straw and fertilization to solve the problem of suspension seed and hanging seedling in no-tillage seedling machinery (Wang, et al., 2018).

In summary, at this stage, there is no machinery designed and manufactured specifically for the characteristics of biochar materials, so this paper studies and designs the key components of biochar return machinery. DEM software Rocky simulation biochar return work process, in this study a Hertzian spring-dashpot model using the DEM was used to model the movement path of particles to measure the effect of biochar return. The structure of components was optimized and the range of main operating parameters was determined based on simulation results. The main parameters affecting the effect of biochar return to the field were determined by Box-Behnken Design, and finally the optimized parameters were obtained and validation tests were conducted.

MATERIALS AND METHODS

Complete machine and key component design

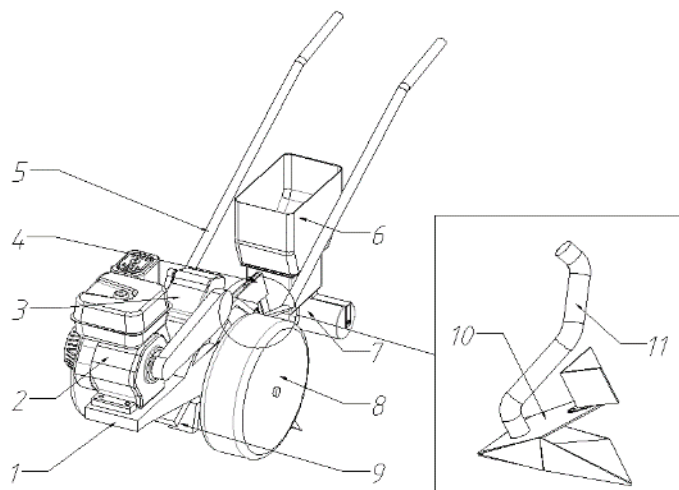

Fig. 1 - Diagram of the whole machine of biochar return machine

1—Mainframe; 2—Gasoline Engine; 3—Transmission; 4—Adjustment Rack; 5—Armrests; 6—Material Box; 7—Mulch Wheel; 8—Traveling wheels; 9—Paddle Wheel; 10—Trenching and Return Shovel; 11—Guide Tube

The whole structure of the biochar return machine is shown in Fig. 1. The working process of the biochar return machine can be divided into three parts: trenching, biochar discharge and soil mulching. The trenching shovel is installed under the connection frame, and the depth of biochar return is changed by the adjustment frame. The whole machine moves forward to drive the paddle wheel to loosen the soil, and the rear return shovel opens out the return ditch to complete the ditching operation. The biochar particles enter the conduit from the material box and flow into the lower shovel surface along the conduit. The mulching wheel at the rear of the machine mulches the returned soil, completing the ditching, biochar discharge and mulching operation.

The key components of the biochar return machine are the components of the biochar discharge system, including the material box, biochar discharger, guide pipe and trenching shovel, which are mainly designed and optimized around the trenching shovel. The main function of the trenching shovel is to open the trench and disperse the biochar particles, so that the biochar particles can be evenly distributed in the soil after returning to the soil. The whole shovel can be divided into three parts: upper shovel, lower shovel and baffle plate, as shown in Fig. 2.

The upper shovel is responsible for trenching and has a through-hole on the shovel face to fit the conduit. The lower shovel is responsible for dispersing the particles, and the shovel surface is equipped with a diversion groove that changes with the position of the upper shovel through-hole, so that the biochar particles can be evenly distributed within the working width of 240 mm after passing through the lower shovel. The upper and lower shovels are equipped with baffles on both sides to prevent the particles from being blown apart. The main structural parameters of the trenching return shovel include: through-hole diameter R , which is the same as the diameter of the guide tube; thickness h ; shovel surface width B , which refers to the total longitudinal length of the upper shovel; shovel surface angle β and width H .

Fig. 3 shows the force diagram of the return shovel, in which the traction force is in balance with all the resistance during the uniform speed operation. According to the force analysis in the figure, the equilibrium equations in the vertical and horizontal directions can be obtained as Equation (1) (2):

$$F_x : F + nN_b(\mu_0 \cos \delta + \sin \delta) = f_{p1} \cos \alpha + N_0 \sin \alpha + N_1 \sin \delta + f_{p2} \cos \delta \tag{1}$$

$$F_y : f_{p1} \sin \alpha + N_1 \cos \delta + n\mu_0 N_b \sin \delta = G + N_0 \cos \alpha + f_{p2} \sin \delta + nN_b \cos \delta \tag{2}$$

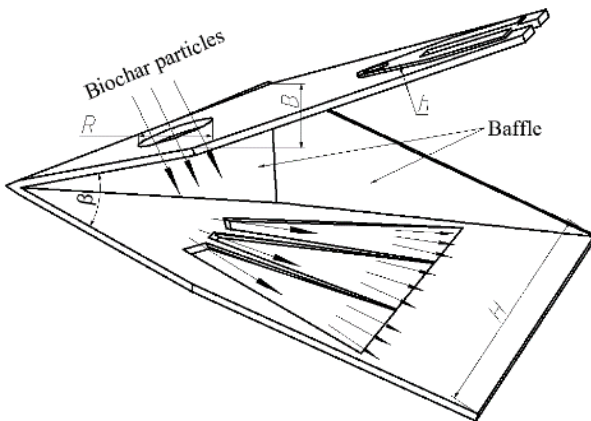

Fig. 2 - Trenching and return shovel

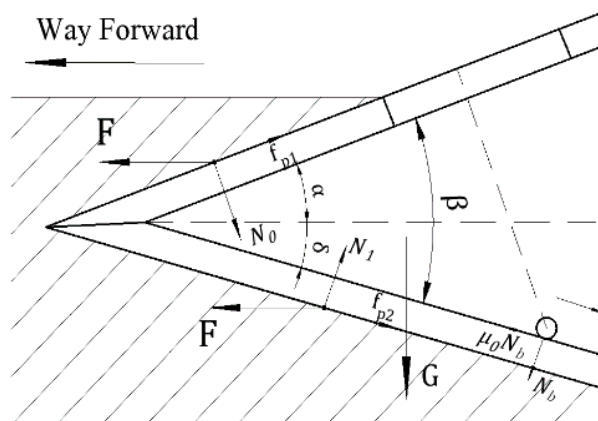

Fig. 3 - Force diagram of return shovel

Where: G is the overall gravitational force on the return shovel; F is the traction force on the shovel, in the same direction as the forward direction; μ_0 is coefficient of rolling friction between biochar and shovel surface; f_{p1}, f_{p2} are the frictional resistance of the soil on the upper and lower shovel surfaces, respectively; N_0, N_1 are the pressure of the soil on the upper and lower shovel surfaces respectively; α is the angle between the upper shovel and the horizontal plane; δ is the angle between the lower shovel and the horizontal plane; N_b is the pressure of biochar particles on the return shovel; n is the number of biochar particles on the lower shovel surface.

Where the pressure generated by the soil on the shovel surface refers to the soil-metal friction mechanism, at relatively low sliding speed (less than 2m/s), the frictional resistance f_p between the metal and the soil is linearly related to the positive pressure N between the two, as shown in Equation (3) (Yao, et al., 1988). Where C' , A are empirical constants, v is the sliding velocity, Φ_a is the external friction angle of the soil, for loamy soils with different water content, the reference range of the above coefficients are taken as shown in Table 1. From the parameters in the table, the frictional resistance of the soil to the metal becomes larger with increasing speed, but if the speed is below a certain threshold value, the frictional resistance is 0. The reference coefficient was chosen for a moisture content of 17.5% with reference to the characteristics of agricultural soils in the northeast. In addition, since the mass of individual biochar particles is very small, the effect of biochar on the return shovel is neglected, and the Equation (4) can be obtained by combining the Equations (1) to (3).

Table 1

Coefficient reference values					
Coefficient	Water content (%)				
	10.0	12.1	17.5	21.8	25.0
C'	30.28	28.11	29.31	26.60	25.31
$tg\Phi_a$	0.3038	0.3177	0.2958	0.2310	0.2553
A	18.38	2.67	24.56	14.72	22.17

$$f_p = C' + A \cdot \ln v + tg\phi_a \cdot N \tag{3}$$

Let $k = C' + A \cdot \ln v$:

$$F = \sum_{i=0}^1 [(k_i + 0.3N_i) \cos \beta_i + N_i \sin \beta_i] \tag{4}$$

Where:

β_0 stands for α ; β_1 stands for δ ; the value of k depends on the sliding speed v ;

The formula for calculating the sliding velocity of the shovel surface and the soil is as in Equation (5).

$$v_i = \frac{2v_c}{\cos \beta_i} \tag{5}$$

Where, v_c is the whole machine forward velocity. Comprehensive Equation (3) to Equation (5) can be seen: the smaller the angle of α and δ , the smaller the sliding speed between the soil and the metal, the smaller the frictional resistance; the greater the forward velocity, the greater the resistance of the soil by the components. In the actual mechanical design requirements, the resistance of the parts in the work should be minimized without affecting the normal operation of the mechanism, but the angle of α and δ is not as small as possible: the size of α will affect the performance of soil entry, too small will lose the loosening effect; δ is too small will make it difficult for the biochar particles to slide down from the lower shovel surface, thus affecting the effect of biochar return. Comprehensive consideration: In order to maintain the effect of loosening soil, refer to the design of deep loosening shovel entry angle of agricultural machinery design manual, take $\alpha=20^\circ$ (Chinese Academy of Agricultural Mechanization Sciences Group., 2007). In order to maintain a certain speed of biochar particles during sliding, $\delta = 15^\circ$ was taken.

Discrete element method simulation

The discrete element software *Rocky* provides the data needed to specifically predict the behavior of particles in agricultural equipment. A three-dimensional model of the biochar return machine was built using the mechanical design software *SolidWorks*, and a simulation model of the biochar return machine was built by *Rocky* to determine key parameters based on the analysis of simulation results. The discrete element simulation requires reasonable determination of various simulation parameters to reflect the real working process. Choosing a suitable mechanical contact model can get reliable analysis results. Since the physical characteristics of biochar particles are similar to those of organic fertilizer, the *Hertzian Spring Dashpot* model was selected as the normal force model, the *JKR* model as the adhesion force model, and the *Linear Spring Coulomb Limit* model as the tangential force model based on the research of discrete element method analysis of organic fertilizer particle application process (Liu, et al., 2021; Zhao, et al., 2021). The material contact parameters are shown in Table 2.

According to the theory of discrete element contact model, the recovery coefficient affects the calculation of normal damping force, while the static/rolling friction coefficient affects the calculation of tangential damping force.

Table 2

Material interaction coefficient			
Material Interaction	Recovery coefficient	Static Friction	Dynamic Friction
Biochar- Biochar	0.6	0.6	0.1
Biochar- Steel	0.6	0.6	0.256

The material selected for this test was corn straw biochar supervised by Shenyang Agricultural University Biochar Engineering Technology Research Center, as shown in Fig. 4. According to the theory of discrete element method, when the non-spherical degree of particles is less than 10%, the effect of setting non-spherical particles on the simulation analysis results is minimal, so Biochar particles are established, the shape type is set to spherical particles, the particle sphere diameter is set to 2 mm, 3 mm and 4 mm, and the

three sizes of particles are 1/3 each (Zhao, et al., 2018). Import the 3D model of key components into Rocky software and set the particle entrance position.

The remaining simulation parameters were as follows: simulation time of 5 s, simulation accuracy of 0.05 s/time, particle generation time of 2 s, and particle mass flow rate of 50 g/s. A slot was added at the end of the shovel to quantify the distribution of biochar particles after the simulation, and the simulation model is shown in Fig. 5.



Fig. 4 - Corn straw biochar pellets

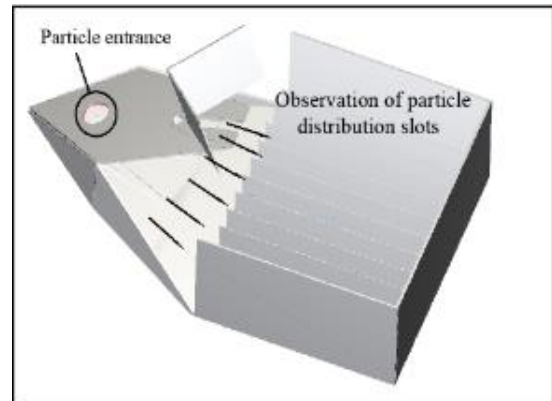

Fig. 5 - Biochar return simulation model

Test design of single factor tests

The key of biochar return technology is how to mix the biochar soil uniformly. In the same depth of soil layer, the uniformity of biochar distribution in the soil will directly affect the return effect, so the coefficient of variation of biochar content uniformity was chosen as the measure of simulation effect. After the simulation test, 12 consecutive sections of 20 mm each were taken within the working width of 240 mm, as shown in Fig. 6.

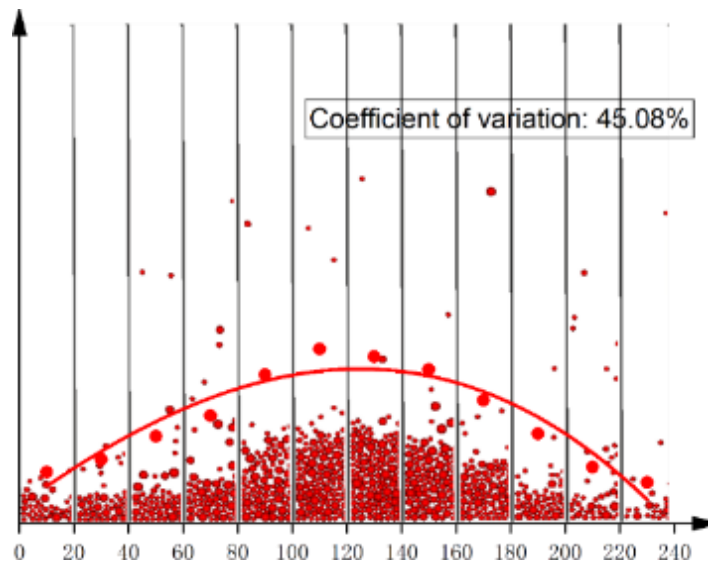

Fig. 6 - Observation trough

The number of biochar particles per section x_i was recorded separately, and the coefficient of variation of biochar content uniformity c_v of the test was:

$$c_v = \sum_{i=1}^n \sqrt{\frac{1}{n-1} \frac{(x_i - \bar{x})^2}{\bar{x}}} \tag{6}$$

The coefficient of variation equation is defined as the standard deviation divided by the mean, and in the above equation, $n-1$ represents the numerator sample standard deviation. Since the number of particles has been determined before the simulation, i.e., the overall mean is determined, the sample standard deviation is chosen.

From the definition of coefficient of variation, it can be seen that the smaller the value of c_v , the smaller the dispersion of the sample data, given a fixed mean value. The smaller the coefficient of variation of biochar content uniformity represents the more uniform distribution of biochar particles after returning to the soil, and the better the effect of biochar return.

Test design of multi-factor tests

A multi-factor simulation analysis was conducted to investigate the effect of the interaction of various factors on the effect of biochar return to the soil. The Box-Behnken response surface method with three factors and three levels in Design-Expert software was selected for the experimental arrangement. The parameter ranges were obtained based on the results of the single-factor test, and the test factors were coded as shown in Table 3.

Table 3

Factor level coding table of the tests

Levels	Factors		
	Outlet distance x_1 [mm]	Conduit diameter x_2 [mm]	Baffle angle x_3 [°]
-1	65	25	10
0	70	30	20
1	75	35	30

RESULTS

Results and analysis of single factor test

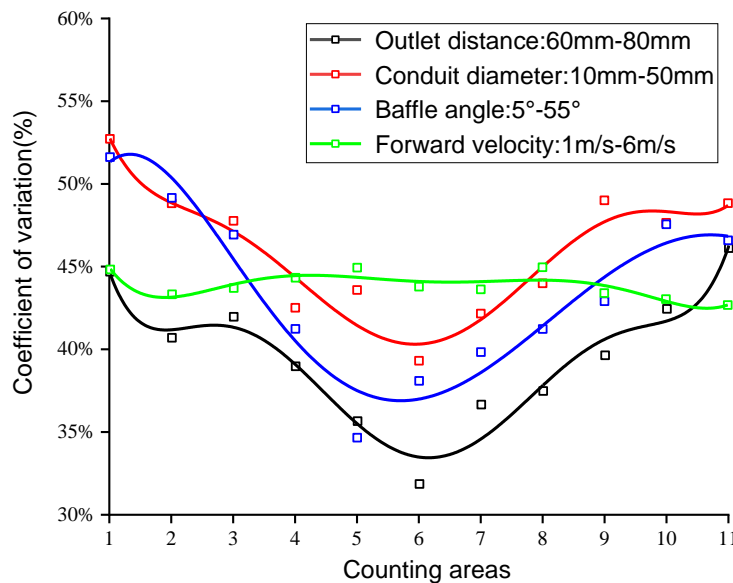

Fig. 7 - Coefficient of variation values at different factor levels

According to the main working parameters of the key components of the structure design, the outlet distance, conduit diameter, forward velocity and baffle angle were selected as the factors for the single-factor test. In order to study the effect of each factor on the return effect, the following ranges of each parameter were obtained: outlet distance 60 mm-80 mm; conduit diameter 10 mm-50 mm; forward velocity 1 m/s-6 m/s; baffle angle 5°-55°. The middle value of each parameter range was taken as the fixed value when other factors were varied, and four groups of mean tests were done, each group eleven times, and the test results are shown in Fig. 7. The test results showed that the values of outlet distance, conduit diameter and baffle angle individually varied significantly on the coefficient of variation of biochar content uniformity under the same conditions of other factors.

The coefficients of variation of conduit diameter and baffle angle were larger at the very small values, and the coefficients of variation of outlet distance and baffle angle were smaller near the median values. In addition, the coefficient of variation was almost not affected by the change of forward velocity. Based on the results of the single-factor test, the outlet distance, conduit diameter and baffle angle were selected as the test factors for the multi-factor simulation test, and the value range of each parameter was further narrowed.

Results and analysis of the Box-Behnken response surface test

The Box-Behnken surface response design test protocol and results are shown in Table 4. The significance test of the test results was performed by using *Design-Expert* software, and the ANOVA on the coefficient of variation of biochar content uniformity was obtained as shown in Table 5. The test results showed that the significant value of model R_1 was $P < 0.001$, and the misfit term was $P > 0.05$, which indicated that the regression equation test of this multi-factor test reached high significance and the fit was good. Therefore, the results of this test can be further analyzed and optimized. The polynomial regression equation obtained after removing the non-significant term is shown in Equation (7).

Table 4

Experiment scheme and results				
Test No.	Factors and levels			Coefficient of Variation R_1 [%]
	Outlet distance x_1 [mm]	Conduit diameter x_2 [mm]	Baffle angle x_3 [°]	
1	70	30	20	40.38
2	65	35	20	30.14
3	70	35	30	35.30
4	70	30	20	40.38
5	70	30	20	40.38
6	75	25	20	33.56
7	65	30	30	31.27
8	70	30	20	40.38
9	65	30	10	31.59
10	70	30	20	40.38
11	65	25	20	29.40
12	75	30	30	37.60
13	75	30	10	39.12
14	70	35	10	37.65
15	75	35	20	40.20
16	70	25	30	33.49
17	70	25	10	34.45

Table 5

Significance test result					
Source	R_1 : Coefficient of Variation				
	SS	df	MS	F	P
Model	265.70	9	29.52	165.83	<0.0001
A	98.56	1	98.56	553.65	<0.0001
B	19.19	1	19.19	107.79	<0.0001
C	3.32	1	3.32	18.62	0.0035
AB	8.70	1	8.70	48.88	0.0002

Source	R_1 : Coefficient of Variation				
	SS	df	MS	F	P
AC	0.36	1	0.36	2.02	0.1980
BC	0.48	1	0.48	2.71	0.1435
A ²	58.87	1	58.87	330.70	<0.0001
B ²	49.01	1	49.01	275.31	<0.0001
C ²	14.28	1	14.28	80.23	<0.0001
Residual	1.25	7	0.18		
Lack of Fit	0.99	3	0.33	5.11	0.0744
Pure Error	0.26	4	0.064		
Cor Total	266.94	16			

$$R_1 = 40.48 + 3.51X_1 + 1.55X_2 - 0.64X_3 + 1.47X_1X_2 - 3.74X_1^2 - 3.41X_2^2 - 1.84X_3^2 \quad (7)$$

According to the regression equation, the response surface plots of the three factors on the coefficient of variation were drawn as shown in Fig. 7. The ANOVA and response surface plot analysis showed that the three factors of outlet distance x_1 , conduit diameter x_2 , and baffle angle x_3 all had significant effects on the coefficient of variation individually, and there was a significant interaction between outlet distance and conduit diameter, but the remaining two interaction effects were not significant, which was due to the fact that the effect of baffle angle on the coefficient of variation was actually controlled by controlling the sliding velocity of biochar particles, and in the reference values of α and δ have been given in the design of the return shovel, and the baffle angle $\beta = \alpha + \delta$. In the single-factor test, the coefficient of variation has the minimum value at $\beta = 30^\circ$. Combined with the analysis of the multi-factor test data, the baffle angle will independently affect the return effect, and the baffle angle should be made to tend to 30° . The outlet distance affects the drop position of biochar and the diameter of the conduit affects the mass flow rate of particles per unit time, and both of them affect each other, and in a given range, the coefficient of variation is greatly reduced when the outlet distance is small and the diameter of the conduit tends to 30 mm.

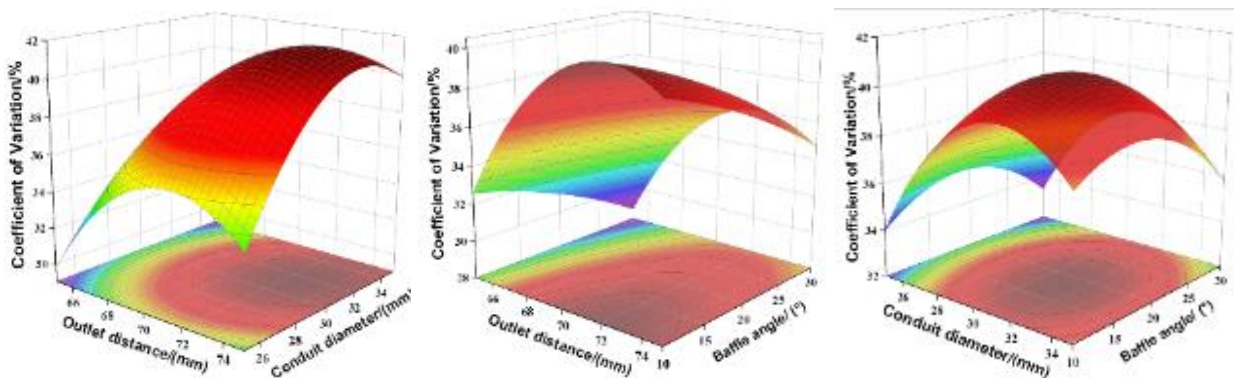

Fig. 8 - Multi-factor Response Surface Plot

Parameter optimization

Parameter optimization of experimental data by *Design-Expert* software, the lower the coefficient of variation of biochar content uniformity, the better the effect of biochar return, and in order to make the baffle angle tend to 30° , set the optimal solution criteria as follows:

$$\begin{cases} \min(R_1) \\ s.t. \begin{cases} 65mm \leq x_1 \leq 75mm \\ 25mm \leq x_2 \leq 35mm \\ x_3 \rightarrow 30^\circ \end{cases} \end{cases} \quad (8)$$

The optimal solution is obtained as: $x_1=65.19$ mm, $x_2=25.29$ mm, $x_3=30^\circ$, $R_1=28.622\%$. Considering the mechanical design and machining process, the actual parameter values were obtained as 65.20 mm outlet distance, 25.30 mm conduit diameter and 30° baffle angle.

Validation tests

The optimized parameters of the key components of the biochar return machine were obtained by discrete element simulation tests. To verify the reliability of the simulation test, the key components of the biochar discharge system were processed and fabricated according to the designed structural parameters and validation test was conducted. The test was conducted on January 20, 2022 at the test site of Shenyang Agricultural University Hougang Experimental Base, Shenyang, Liaoning Province. The machine was put into the test soil tank with low-speed gearing, as shown in Fig. 8, and the number of particles per 20 mm interval in the working width at a certain forward distance was recorded at the end of the machine work, as shown in Figure 9. The coefficient of variation of biochar content uniformity in the low-speed gear can be calculated as 26.44%, and the average relative error with the theoretical optimum value is 7.80%.

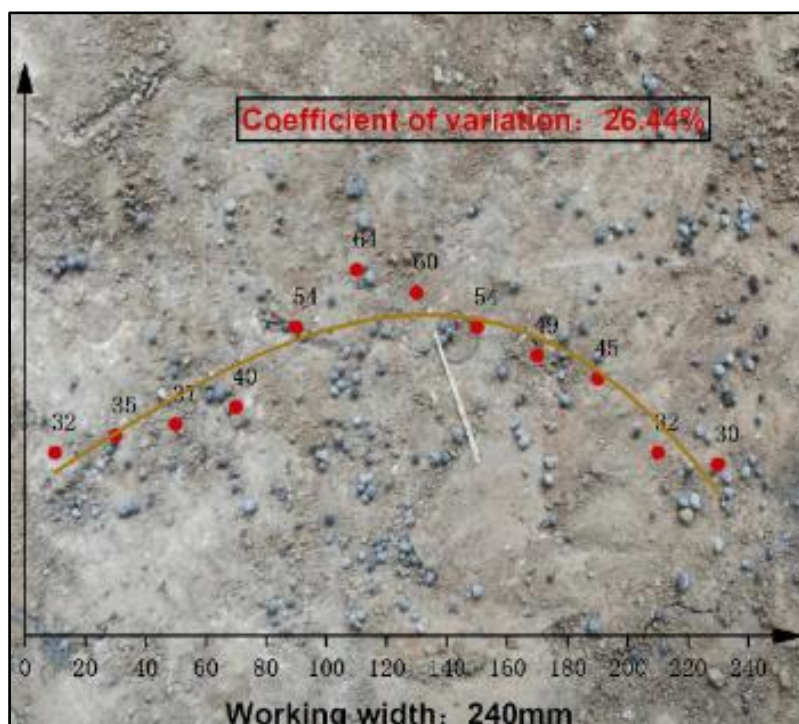

Fig. 10 - Top view of particle distribution

CONCLUSIONS

(1) To realize the integrated technology of biochar return to the soil, this paper designs the key components of the biochar discharge system applicable to the biochar return machine, which can evenly return the biochar to the soil and provide beneficial effects to the root systems of various crops.

(2) Single factor and multi factor tests were conducted by the discrete element simulation software *Rocky*. The range of the main working parameters and the optimal parameters affecting the return effect were obtained. Significance tests and response surface analysis showed that all three factors had significant effects on the biochar return effect, and there was a significant interaction between outlet distance and conduit diameter.

(3) Based on the optimal combination of working parameters: 65.20 mm outlet distance, 25.30 mm conduit diameter and 30° baffle angle, key components were fabricated and tested. The test showed that the best return effect was achieved with the working parameters, and the coefficient of variation of biochar content uniformity could reach 26.44%.

ACKNOWLEDGEMENT

This research was funded by the Project supported by the Science and technology program project of Liaoning Province (2021-MS-232).

REFERENCES

- [1] Cheng Xiaoyi, Meng Jun, Huang Yuwei, Lliang Hao, E Yang, He Tianyi, Lan Yu., (2016), Effect of Biochar on Root Growth, Absorption of Nitrogen and Maize Yield. *Journal of Shenyang Agricultural University*, Vol.47, Issue 2, pp.218-223.<http://doi:10.3969/j.issn.1000-1700.2016.02.015>
- [2] Hu Hong, Li Hongwen, Li Chuanyou, Wang Qingjie, He Jin, Li Wenyong, Zhang Xiangcai (2016), Design and experiment of broad width and precision minimal tillage wheat planter in rice stubble field (稻茬田小麦宽幅精量少耕播种机的设计与试验), *Transactions of the Chinese Society of Agricultural Engineering*, Vol.32, Issue 4, pp.24-32, <http://doi:10.11975/j.issn.1002-6819.2016.04.004>
- [3] Liu Lijing, Ma Chao, Liu Zhongjun, (2021), EDEM-based simulation and experimental research on the effect of full-layer fertilization shovel in corn subsoiling, *Transactions of the Chinese Society for Agricultural Machinery*, <https://kns.cnki.net/kcms/detail/11.1964.s.20210831.1044.006.html>
- [4] Liu Xiaosheng, Lu Haiying, Cui Hongbiao, Hu Youbiao., (2018), Field application of straw biochar and its environment risk: A review (秸秆生物炭还田应用及环境风险综述), *Jiangsu Agricultural Sciences*, Vol.46, Issue 24, pp.28-35, <http://doi:10.15889/j.issn.1002-1302.2018.24.007>;
- [5] Liu Zhongze, Zhou Weiyan, Lu Haopeng, Cao Xingqiao, Meng Bing., (2021), Design of Straw Deep Burying and Returning Fertilizer, *Agricultural Science & Technology and Equipment PhD dissertation*, Issue 4, pp.21-22, Shenyang /P.R.C;
- [6] Mechanization Sciences Group. (2007) *Agricultural Machinery Design Manual*, China Agricultural Science and Technology Press, Beijing/P.R.C;
- [7] Sukhbir, Singh, Ashok Tripathi, A. K., Singh., (2017), Effect of Furrow Opener Design, Furrow Depth, Operating Speed on Soil Characteristics, *Draft and Germination of Sugarcane*, Vol.19, Issue 5, pp.476-484.<http://doi:10.1007/s12355-016-0499-x>
- [8] Wang Chaoqun, Cao Chengmao, Qin Kuan, Liao Yishan, Guo Yibo, Fan Yakui, Ma Shilong., (2018), Design and experiment of no-tillage planter with smashing straw and fertilization, *Journal of Anhui Agricultural University*, Vol.45, Issue 6, pp.1154-1159, <http://doi:10.13610/j.cnki.1672-352x.20190102.021>
- [9] Wei Yongxia, Xiao Jingping, Wang He, Shi Yun, Liu Hui., (2020), Continual Influences of Applying Biochar on Soil Improvements in Sloping Farmland of Black Soil Region in Northeast China , *Transactions of the Chinese Society for Agricultural Machinery*, Vol.52, Issue 3, pp.305-314, <http://doi:10.6041/j.issn.1000-1298.2020.S1.020>;
- [10] Yang Qinglu, Huang Xingyuan, Wang Qingjie, Li Hongwen, Wang Yingbo, Wang Lanyue., (2020), Structure Optimization and Experiment of Corn Layered Fertilization Device , *Transactions of the Chinese Society of Agricultural Machinery*, Vol.51, Issue S1, pp.175-185, <http://doi:10.6041/j.issn.1000-1298.2020.S1.020>;
- [11] Yao Yusu, Zeng Dechao., (1988), Investigation on the Relationship Between Sliding Speed and Soil-Metal Friction, *Transactions of the Chinese Society of Agricultural Machinery*, Issue 4, pp.33-40, Beijing/P.R.C;
- [12] Zhang Weiming, Chen Wenfu, Meng Jun, Jin Liang, Guo Wei, Zhao Hongliang., (2019), Study of Straw-Biochar on Utilization Potential, Industry Model and Developing Strategy in Northeast China, *Scientia Agricultura Sinica*, Vol.52, Issue 14, pp.2406-2424.<http://doi:10.3864/j.issn.0578-1752.2019.14.003>
- [13] Zhao Shiwei., (2018), Discrete Element Investigation of Physical and Mechanical Properties of Granular Materials, *South China University of Technology*, Guangdong/China;
- [14] Zhao Shuhong, Liu Hanming, Yang Chao, Yang Luoluo, Gao Lianlong, Yang Ruiqian., (2021), Design and Discrete Element Simulation of Interactive Layered Subsoiler with Maize Straw Returned to Field, *Transactions of the Chinese Society for Agricultural Machinery*, Vol.52, Issue 3, pp.75-87. <http://doi:10.6041/j.issn.1000-1298.2021.03.008>