

EXPERIMENTAL STUDY ON AIR FLOW FIELD CHARACTERISTICS OF SUCTION METERING DEVICE

气吸式排种器的气流场特性试验研究

Meng Zhang¹⁾, Zeqi Liu¹⁾, Yajun Zhuang¹⁾, Jie Han¹⁾, Yin Xiang^{1,3)}; Chen Yulong^{*1,2)}

1

¹⁾ School of Agricultural Engineering and Food Science, Shandong University of Technology, Zibo 255000, China;

²⁾ Research of Institute of Ecological Unmanned Farm, Shandong University of Technology, Zibo 255000, China;

³⁾ Shandong Provincial Key Laboratory of Dry-Farming Machinery and Informatization, Zibo 255000, China;

Tel: +86 15315206471; E-mail: 1097402292@qq.com

DOI: <https://doi.org/10.35633/inmateh-65-06>

Keywords: vacuum seed metering device, air flow field characteristics, experimental study, composite disc, vacuum chamber

ABSTRACT

The vacuum seed metering device absorbs seeds by using the negative pressure generated by vacuum air flow. Therefore, it is of great significance to study the variation law of pyrolysis gas flow field to improve its seed metering performance. In this paper, the common disc and composite disc were selected as the research objects and tested on the indoor test-bed. The negative pressure was measured by U-type barometer, and the effects of fan speed, suction hole size, seed hole structure and air chamber thickness on the air flow field were studied. Firstly, the influence of fan rotation frequency on vacuum chamber negative pressure is studied, and the variation law of negative pressure in vacuum chamber and fan port of common disc and composite disc under the same frequency is compared. Secondly, the suction holes in the vacuum chamber were numbered, the negative pressure distribution of the suction holes was measured, and the influence of the number and diameter of the suction holes on the negative pressure of the vacuum chamber was studied. Finally, the negative pressure was measured at the distance of 0 to 10 mm from the suction hole to study the effect of seed hole structure on the air flow field. Moreover, increase the additional thickness of the vacuum chamber from 0 to 40 mm to study the influence of the chamber thickness on the distribution of the gas flow field. This paper makes a comprehensive experimental analysis on the influencing factors of air flow field of air suction seed metering device, necessary for future design of air suction seed metering device.

摘要

气吸式排种器的利用真空气流产生负压吸取种子，了解气流场的变化规律对提高其排种性能具有重要意义。本文选取常规盘和复合盘作为研究对象，在室内试验台上进行试验，利用U型压力计对负压进行测量，对风机转速、吸孔尺寸、取种孔结构、气室的厚度对气流场的影响规律进行研究。首先通过变频器调节风机的转速，研究风机频率对气室负压的影响，对比相同频率下常规盘和复合盘的气室负压及风机口的负压变化；然后，对气室范围内的吸孔编号并测量吸孔的负压分布规律；以常规盘为对象研究吸孔的数量和直径对气室负压的影响；最后分别在距离吸孔0至10mm距离测量负压，研究取种孔结构对气流场的影响；并且增加气室的附加厚度分别为0至40mm，研究气室厚度对气流场的分布影响。本文对气吸式排种器的气流场影响因素进行全面的试验分析，试验结果对气吸式排种器的优化设计具有重要参考价值。

INTRODUCTION

The precision seed metering device (Yang et al., 2016) is the core component of the seeding machine, which seeds at a certain soil depth according to the optimal row and plant spacing in the agronomic requirements (Abdolahzare et al., 2018; Mao et al., 2015). The precision seed metering device can be divided into the mechanical (Chen et al., 2021; Liu et al., 2015; Wang et al., 2017), vacuum and air-pressure (Yang et al., 2016) type by the operating principle. Among others, the vacuum seed metering device features a simple structure, easy operation and maintenance and high seed suitability, becoming the most widely applied device (Liao et al., 2018). Such seed metering devices extract the air in the vacuum chamber with a fan, causing the chamber to vacuum. Then, they utilize the negative pressure to absorb seeds through the suction hole and

¹ Meng Zhang, M.S. Stud. Eng.; Zeqi Liu, M.S. Stud. Eng.; Yajun Zhuang, M.S. Stud. Eng.; Jie Han, M.S. Stud. Eng.; Yubin Lan, Prof. Ph.D. Eng.; Yulong Chen, Lecture Ph.D. Eng.

complete the seed filling. Many researchers have studied the vacuum seed metering device and established mathematical models of the vacuum seeding operation process (Cujbescu *et al.*, 2019). They further took advantage of cameras and photoelectric sensors to test the seeding performance and analyzed the performance with the bench test (Zhao *et al.*, 2015). The fluid simulation software has also been applied to simulate (Yu *et al.*, 2015; Zhang *et al.*, 2015) and analyze the airflow field of the seed metering device (Liu *et al.*, 2013; Yu *et al.*, 2014), thus optimizing the shape design of the suction hole and the seed disturbing mechanism (Dylan, S. J. *et al.*, 2013; Singh *et al.*, 2007; Xing *et al.*, 2020).

Based on the operating principle of the vacuum seed metering device, it can be found that the airflow field can greatly affect the seed filling performance. The existing researches on the vacuum seed metering device mainly focused on the seed-absorbing performance of the negative pressure airflow (Yu *et al.*, 2015; Zhang *et al.*, 2020), but neglected the impact of the fan speed, component structure near the suction hole and vacuum chamber structure on the airflow field. Therefore, in this paper, the above factors are applied in research so as to deeply explore the airflow field characteristics of vacuum seed metering devices.

MATERIALS AND METHODS

Vacuum seed metering device

Two different types of seed discs are installed with consistent shells and covers to make thorough experiment and study on the airflow field characteristics of the vacuum seed metering device. One of the discs is a common round flat steel disc (Singh *et al.*, 2007), 2 mm thick, with round suction holes evenly distributed along the circumference. The other disc is a composite plastic round disc (Jia *et al.*, 2018), 7 mm thick, designed by the author in early preparations. Several churning and filling grooves are evenly distributed along the circumference, and there are suction holes at the bottom of the filling groove.

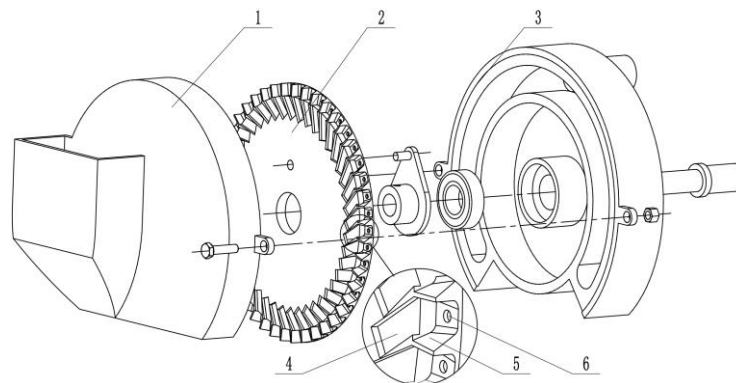

a. *Vacuum seed metering device with composite disc*

b.

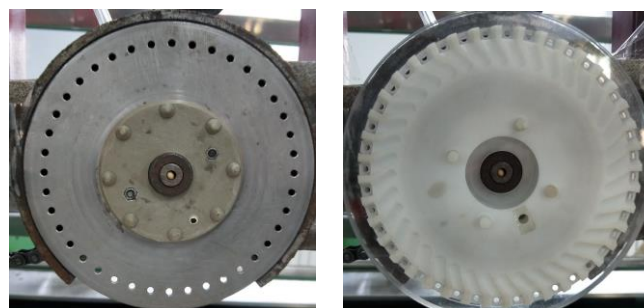

b. *Common disc*

c. *Composite disc*

Fig. 1 - Vacuum seed metering device and disc

1. Shell; 2. Disc; 3. Base; 4. Seed agitator; 5. Seed hole; 6. Suction hole

The common disc is further divided into soybean disc (SD) and corn disc (CD) as they differ in the diameter and number of the holes. The SD has 40 suction holes and the CD 20 holes; the hole diameter for the SD is 4 mm, and 5.5 mm for the CD. These two common seed discs are studied to find the impact of the number and diameter of suction holes on the airflow field.

Table 1

Design parameters of disc

Parameter	SD	CD
Diameter of disc[mm]	200.0	200.0
Thickness of disc [mm]	2.0	2.0
Number of suction holes [piece]	40.0	20.0
Diameter of suction hole[mm]	4.0	5.5

The vacuum chamber contained in the seed metering device is 20 mm deep and the coverage reaches 270° along the circumference. Suction holes are numbered from the lower-left corner, clockwise from left to right. The SD contains 30 holes in the coverage of the negative pressure chamber, but the CD contains only 15 holes.

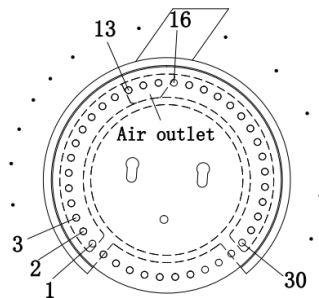

Fig. 2 - Distribution of suction holes on disc

Test plan

The experiment is carried out on an indoor bench (Zhang et al., 2015). The seed metering device is driven by a 3-phase AC motor and the negative pressure is generated by the centrifugal fan with the pressure value directly proportional to the fan speed. The fan speed is controlled by a frequency converter and the pressure at the fan outlet is displayed on the digital screen (Fig. 3).

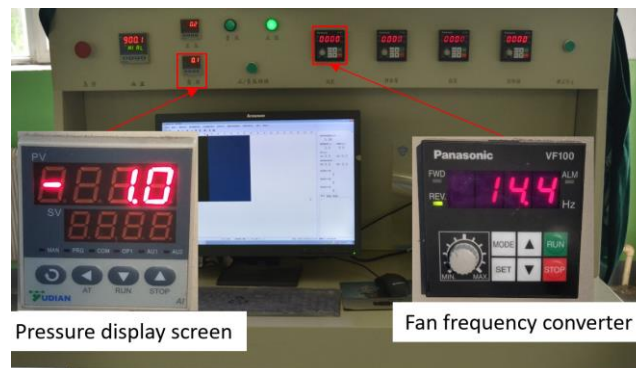

Fig. 3 - Control cabinet of test bench

The vacuum chamber pressure of the metering device is measured with a U-type barometer (Fig. 4 a). Then, the altitude difference of both liquid columns of the U-type barometer is applied to calculate the pressure difference in accordance with the Formula (1).

$$\Delta P = \rho \cdot g \cdot \Delta h / 1000 \tag{1}$$

where: ΔP is the column pressure difference of the barometer, kPa; Δh is the column altitude difference, m, twice the reading of the U-type barometer; ρ is the liquid density in U-shaped columns, water is applied in this paper as the pressure measuring media and the ρ is 1000 kg/m³.

Punching is carried out at the side of the vacuum chamber outlet and the outlet pressure is measured with the U-type barometer, as shown in Fig. 4 b.

As the circumference of the vacuum chamber is wide, different areas vary in the distance away from the outlet and the air pressure differs consequently. The U-type barometer is applied to measure the pressure values of suction holes at distinct sites respectively.

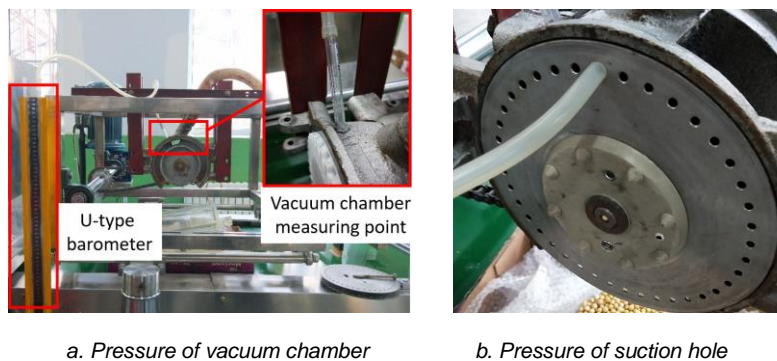

Fig. 4 - Measure the negative pressure with a U-type barometer

A vacuum chamber adjustment disc is installed based on the original coverage of the vacuum chamber to study the impact of vacuum chamber depth on the airflow field. The adjustment disc is composed of a 5 mm thick PMMA disc. With more adjustment discs added, additional vacuum chamber thickness will be modified to 5, 10, 15...40 mm respectively, as shown in Fig. 5.



Fig. 5 - Adjustment of vacuum chamber thickness

RESULTS AND ANALYSIS

Fan speed and negative pressure of vacuum chamber

After adjustment of the fan speed and negative pressure with the frequency converter, the negative pressure readings on the screen are adjusted to be 1, 2, 3 kPa respectively. The frequency converter readings are recorded and the U-type barometer is applied to measure the outlet pressure. The results are shown in Table 1.

Table 1

Fan frequency and negative pressure		
Negative pressure on display	Fan frequency / Hz	
	Common disc	Composite disc
1.0	14.6±0.2a	14.4±0.3a
2.0	21.2±0.2a	21.0±0.2a
3.0	26.0±0.3a	25.6±0.2a
4.0	30.2±0.2a	30.0±0.3a
5.0	33.8±0.4a	33.6±0.2a

Note: When small letters in two columns and the same row resemble, it means the difference is not significant. However, when the small letters are different, the difference is significant.

Based on Table 1, it can be found that when the negative pressure values on the screen are the same, the small letter in all rows is a, indicating that two digits in each row are not significantly different. The fan frequencies corresponding to the common and composite discs respectively do not differ significantly, showing that the seed disc structure does not affect the fan outlet pressure greatly.

As the actual pressure value of the vacuum chamber changes according to the suction hole size and number as well as the number of seeds absorbed in the hole, it is unable to accurately control the negative pressure value of the vacuum chamber. Among multiple parameters related to the vacuum chamber pressure, only fan speed can be accurately controlled with the frequency converter. Therefore, in this paper, the fan frequency is adjusted to control its speed. The fan frequency values of the composite disc, 14.4, 21.0, 25.6, 30.0, 33.6, are applied as the benchmark for negative pressure regulation as mentioned below with the corresponding negative pressures, 1.0, 2.0, 3.0, 4.0, 5.0 kPa respectively.

The fan frequency is adjusted and the U-type barometer is used to measure the fan outlet and vacuum chamber pressure values of the common disc and composite disc. The results are shown in Fig. 6.

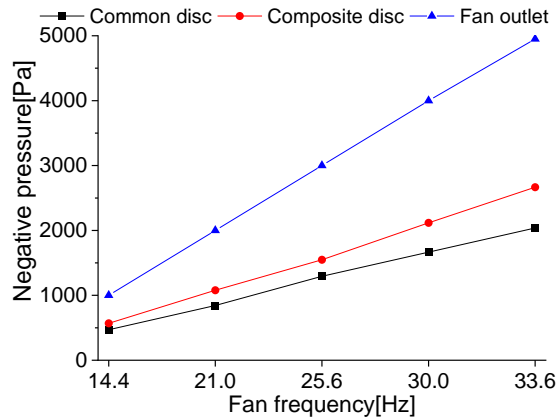

Fig. 6 - Relationship between fan frequency and pressure of vacuum chamber

From Fig. 6, the negative pressures of vacuum chambers for two seed discs are significantly lower than the negative pressures at the fan outlet, indicating that air pressure is greatly reduced in the delivery pipeline. The negative pressure of the composite disc is larger than that of the common disc. In addition, as the fan frequency grows, the negative pressure difference is also enlarged, showing that the pressure loss of the composite disc is lower than that of the common disc.

The following regression equation is obtained after conducting regression analysis of vacuum chamber negative pressures of the common and composite discs:

$$\begin{cases} y_1 = 416.23x, & R^2 = 0.9956 \\ y_2 = 530.27x, & R^2 = 0.9986 \end{cases} \quad (2)$$

where:

y_1 is the vacuum chamber negative pressure of the common disc;

y_2 is the vacuum chamber negative pressure of the composite disc and x is the fan frequency.

Negative pressure distribution in the vacuum chamber

For SD as the study object, the negative pressure value is measured with the U-type barometer at each suction hole in the vacuum chamber. The results are shown in Fig. 7.

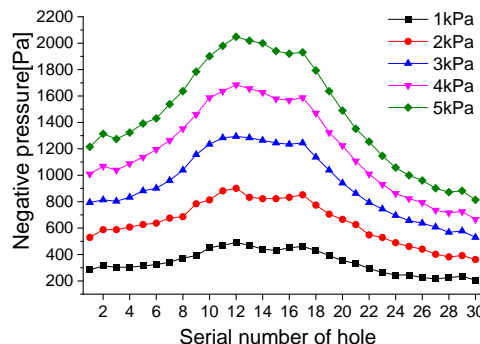

Fig. 7 - Negative pressure of each suction hole within the air chamber

The negative pressure at both ends of the vacuum chamber is relatively small. It increases as the distance with the outlet is smaller; while the suction holes 13-16 opposite to the outlet are not equipped with the maximum negative pressures, but slightly smaller than that of holes 12 and 17 nearby. The maximum negative pressure is measured near the outlet and the pressure at the outlet decreases slightly.

Airflow in the U-shaped vacuum chamber flows to the outlet in both directions and gathers at the middle position. Then, at the intersection, these airflows collide, forming cavitation where the airflow speed is slow. Therefore, the negative pressure near the vacuum chamber outlet is smaller than the pressure on both sides.

The negative pressures of suction holes 1-12 on the left of the outlet are smaller than those of holes 17-30 on the right. The static pressure at the left end of the vacuum chamber is significantly larger than that at the right end. Since the outlet is inclined by 45° on the left side, the air on the right side flows to the outlet smoother. However, air on the left side may be reversed when it flows to the outlet, leading to the airflow being obstructed.

Impact of suction hole parameters on the airflow field

The SD is taken as the research object to study the influence rules of hole number on negative pressure. SD has 30 suction holes in the vacuum chamber. Tape is used to seal 5 holes evenly per time to reduce the hole number in the chamber as 25, 20 and 15. Measured values of negative pressure of the vacuum chamber with different hole numbers and the results are shown in Fig. 8.

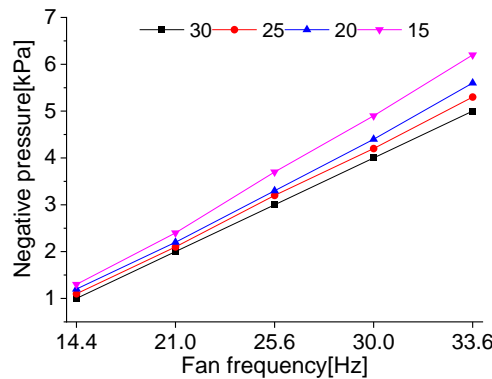

Fig. 8 - Effect of the number of suction holes on the pressure of vacuum chamber

From Fig. 8, it can be found that the hole number significantly influences the negative pressure value. Under the same fan frequency, the negative pressure of the vacuum chamber gradually increases with reduction of the hole number. Besides, the larger the frequency is, the more significant the growing tendency of the negative pressure is.

As the operation objects of the seed metering device vary, the hole diameter differs as well.

Generally, the larger seed size applies to larger hole diameter. SD and CD are applied to study the impact of suction hole diameter on the airflow field. To ensure consistent hole numbers, tapes are used to evenly seal 20 holes of the SD.

With the fan frequency adjusted as 14.4, 21.0, 25.6, 30.0 and 33.6 Hz, negative pressures of fan outlet and vacuum chamber of SD and CD are measured. The results are shown in Fig. 9.

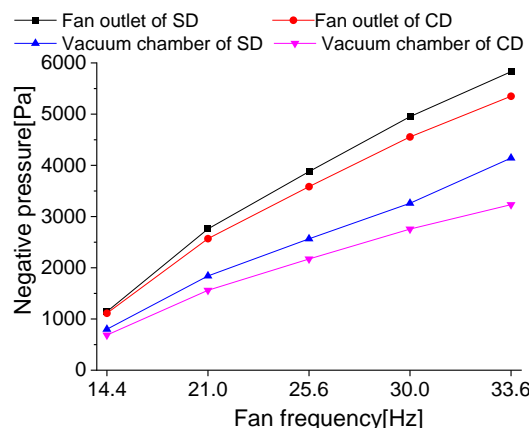

Fig. 9 - Effect of suction hole diameter on macro negative pressure

From Fig. 9, it can be found that the negative pressure of the SD fan outlet is larger than that of the CD fan and the negative pressures at outlets of the vacuum chamber are similar. This means that as the hole diameter increases, the vacuum chamber pressure decreases significantly and the decreasing tendency grows when the fan speed enlarges.

The hole negative pressure in the vacuum chamber is measured. Fifteen suction holes are in the vacuum chamber and they are numbered clockwise. The U-type barometer is used to measure the hole pressure one by one. The results are shown in Fig. 10.

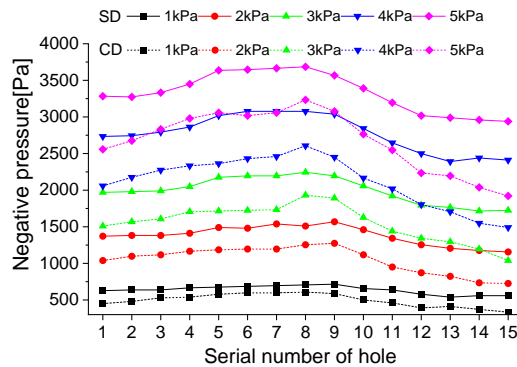

Fig. 10 - Influence of suction hole diameter on its negative pressure

From Fig. 10, it can be found that when the fan speed remains the same, the negative pressure of SD always outweighs that of CD and the pressure difference is larger as the fan speed is higher. This means that when the suction hole diameter is larger, the negative pressure grows as well.

Impact of seed hole structure on the negative pressure of suction hole

Common discs are flat and there is no other structure around the hole. On the contrary, outside the suction hole of the composite disc is a filling groove, which affects the airflow motion near the suction hole. When the negative pressure is 3 kPa, the pressures 0, 2, 4, 6, 8 and 10 mm away from the suction hole are respectively measured. Represented by holes 1, 6, 11, 16, 21 and 26 selected, the results are shown in Fig. 11.

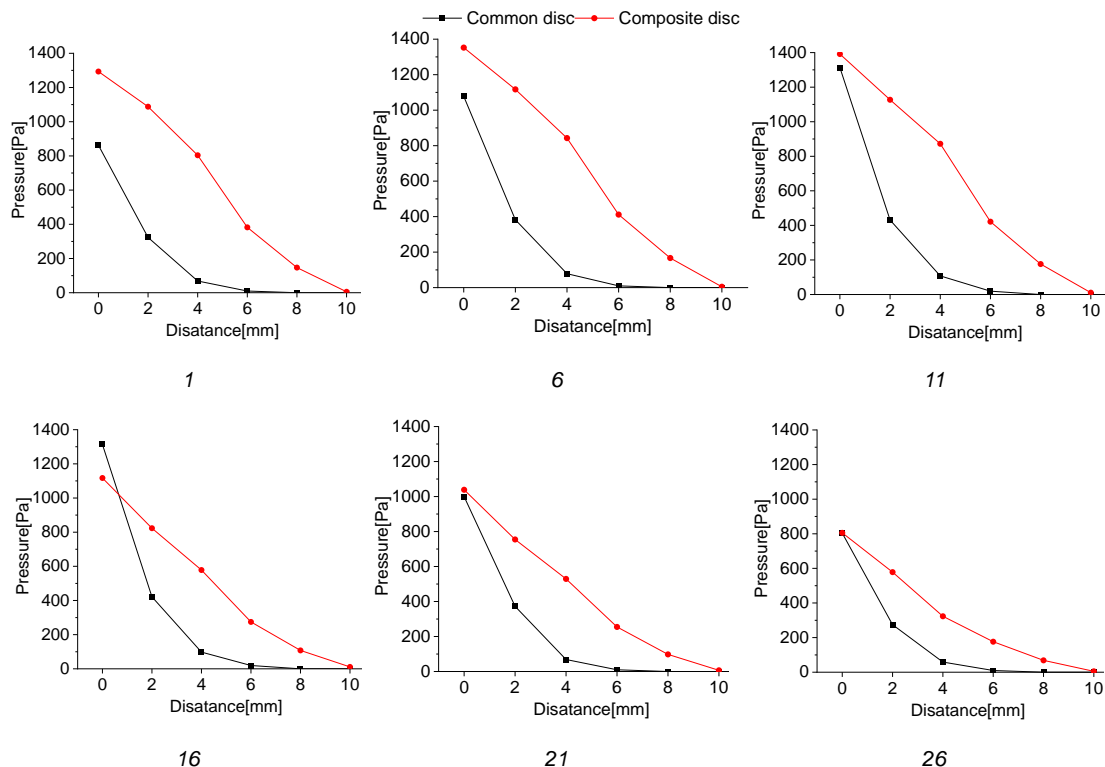

Fig. 11 - Effect of seed hole on negative pressure near suction hole

It can be found that as the distance enlarges, the negative pressure surrounding suction holes of the common disc decreases faster and the negative pressure changes at different areas of the vacuum chamber are similar. When the distance increases from 0 mm to 2 mm, the negative pressure decreases greatly; with the distance increasing from 2 mm to 4 mm, the pressure reduction slows down. The negative pressure approaches 0 when the distance reaches 6 mm and above. Namely, with the vertical distance between a seed and the hole being 6 mm, the suction force of airflow on the seed is negligible.

The negative pressure attenuation rate near suction holes of a composite disc is significantly slower than that of a common disc. In addition, with the same distance, the negative pressure of the composite disc is larger than that of the common disc except for individual holes. As the distance grows from 0 mm to 10 mm, the negative pressure attenuation of each suction hole in the vacuum chamber changes linearly. The negative pressure of each hole is larger than 0 when the distance is 6 mm and 8 mm. Namely, when the vertical distance between a seed and the suction hole is 8 mm, the airflow can intake the seed as well and filling operation is available. But the negative pressure approaches 0 when the distance reaches 10 mm. The suction force is unavailable in filling operation.

When the distance is 0 mm, the negative pressure difference between the common and composite discs is small. At holes 1 and 6, the negative pressure of the composite disc is slightly larger than that of the common disc. However, at holes 11, 21 and 26, the difference is insignificant. At hole 16, the common disc pressure is larger than the composite disc pressure. In addition, when the distance is larger than 0, the negative pressures of the common and composite discs vary significantly. The negative pressure at each hole of the composite disc is significantly larger than that of the common disc. As the distance remains 2 mm and 4 mm, the pressure difference increases. When the distance exceeds 6 mm, the difference narrows. As the distance reaches 10 mm, the negative pressure of the composite disc approaches 0.

The filling groove of the composite disc broadens the range of action of negative pressure and increases the air-suction filling performance of the suction hole, thus further improving the filling performance of the seed metering device at low negative pressure.

Impact of chamber thickness on air pressure

SD is taken as a research object to study the impact of chamber thickness on the airflow field. Additional thicknesses of the vacuum chamber adjustment disc are set as 0, 5, 10 to 40 mm. When the display screen shows 1.0, 2.0, 3.0 to 5.0 kPa, the corresponding frequency converter values are recorded. The results are shown in Table 2.

From Table 2, it can be found that as the additional disc thickness increases from 0 to 25 mm, the fan frequency does not change significantly with the fan outlet pressure remaining the same. This means that when the fan speed is fixed and the additional chamber thickness is not greater than 25 mm, the chamber thickness changes do not significantly influence the negative pressure at the fan outlet.

Table 2

Fan frequency corresponding to additional thickness of vacuum chamber									
	0 mm	5 mm	10 mm	15 mm	20 mm	25 mm	30 mm	35 mm	40 mm
1 kPa	14.4 c	14.3 c	14.5c	14.4 c	14.3c	14.5c	14.9b	15.4b	16.2a
2 kPa	21.1 d	21.0 d	21.4 d	21.2 d	21.3 d	21.2 d	21.6 c	22.3 b	22.8a
3 kPa	25.5 d	25.6 d	25.6 d	25.4 d	25.7 d	25.4 d	26.5 c	26.9b	27.4a
4 kPa	30.1 d	30.0 d	30.3 d	30.2 d	30.4 d	30.3d	30.8c	31.4b	32.1a
5 kPa	33.7 c	33.6 c	33.5 c	33.6 c	33.5 c	33.4c	33.9b	34.3b	35.2a

However, when the additional thickness reaches 30 mm and above, the fan frequency required to maintain the same negative pressure significantly enlarges with greater energy consumption. When the additional thickness exceeds 30 mm, the air pressure loss is significant. Therefore, the additional thickness may not exceed 25 mm.

When the additional thickness is from 0 to 25 mm and the negative pressure is 3 kPa, the negative pressures of suction holes 1, 6, 11, 16, 21 and 26 are measured. The measured results are shown in Fig.12.

From Fig. 12, it can be found that with different additional thicknesses, the negative pressure changes similarly at each suction hole. The pressure of hole 1 is relatively small, but as the hole number enlarges, the negative pressure increases as well and reaches the peak at hole 11 or 16. Furthermore, as the number

increases, the negative pressure decreases. So, the pressure at hole 26 is the minimum. The negative pressure at different areas of the chamber changes the most when the additional thickness is 0 mm (i.e., original vacuum chamber). The pressure difference is 563.5 Pa between hole 1 and hole 16. Between hole 26 and hole 16, it is 671.3 Pa. As the additional thickness increases, the pressure difference between different chamber areas is narrowed gradually. When the additional thickness is greater than 20 mm, the negative pressure difference at different areas is relatively small and the pressure distribution in the vacuum chamber is uniform. However, when the distance is 25 mm, the negative pressures at all suction holes are smaller than pressure with a distance of 20 mm. To enhance the uniform distribution of negative pressures in the vacuum chamber, the chamber thickness can be raised to 20 mm.

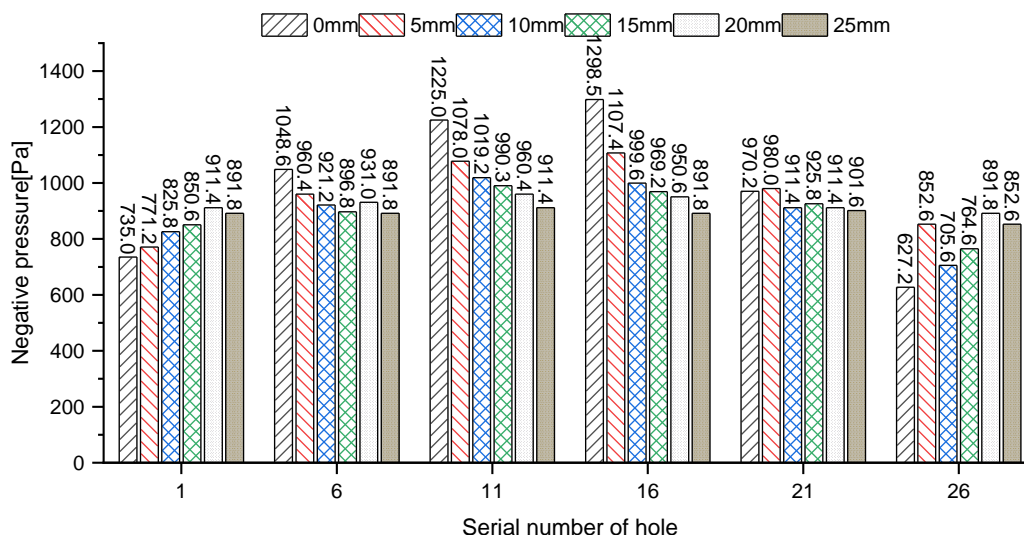

Fig. 12 - Effect of chamber thickness on suction hole pressure

CONCLUSIONS

(1) In the comparison of fan frequency between the common disc and composite disc, it can be found that the impact of seed disc structure on the fan outlet pressure is not significant. But the air pressure suffers great losses in the delivery pipeline and the pressure loss of composite disc is smaller than that of the common disc. At the same time, the regression equation between the negative pressure of the vacuum chamber and fan frequency is established.

(2) Negative pressures at both ends of the U-shaped vacuum chamber are relatively small, but the pressure value increases as the measured site is nearer the outlet. The negative pressures on both sides of the outlet are the maximum, but the pressure of suction holes opposite to the outlet is slightly reduced.

(3) The number and diameter of hole significantly influences the negative pressure value. As the hole number decreases, the negative pressure of the vacuum chamber gradually increases; with enlargement of the fan frequency, the negative pressure growing tendency is more significant. The chamber pressure significantly decreases with increase of the hole diameter and the decreasing tendency is enhanced as the fan frequency increases.

(4) Regulating the chamber thickness with the adjustment disc can enhance the negative pressure uniformity in the vacuum chamber. When the additional chamber thickness reaches 20 mm, the pressure uniformity in the vacuum chamber is optimal with the best negative pressure value.

ACKNOWLEDGEMENT

This work was supported by the National Natural Science Foundation of China (Grant No. 51905318), Shandong Provincial Colleges and Universities Youth Innovation Talent Induction Program (Smart Agriculture Research and Innovation Team), Top Talents Program for One Case One Discussion of Shandong Province ([2018]27), and Zibo School City Integration Project Academy of Ecological Unmanned Farm (Grant No. 2019ZBXC200).

REFERENCES

- [1] Abdolahzare, Z., & Mehdizadeh, S. (2018), Nonlinear mathematical modeling of seed spacing uniformity of a pneumatic planter using genetic programming and image processing, *Neural Computing and Applications*, vol.29, issue 2, pp. 363-375; <https://doi.org/10.1007/s00521-016-2450-1>

- [2] Chen, Y. L., Zhang, M., Liu, Z. Q., Lan Y. B., Yi, L. L., Peng, Q. J., & Yin, X. (2021), Design and experiment of seed agitator for vertical disk seed metering device, *INMATEH - Agricultural Engineering*, vol. 63, issue 1, pp.179-188;
- [3] Cujbescu, D., Matache, M., & Voicu, G. (2019), Mathematical model for sowing precision estimation of vacuum seed metering device, *UPB Scientific Bulletin, Series D: Mechanical Engineering*, vol.81, issue 3, pp. 225-234.
- [4] Dylan, S. J., Hesterman, D. C., & Guzzomi, A. L. (2013) Precision metering of Santalum spicatum (Australian Sandalwood) seeds, *Biosystems Engineering*, vol.115, issue 2, pp.171-183; <https://doi.org/10.1016/j.biosystemseng.2013.03.004>
- [5] Jia, H. L., Chen, Y. L., Zhao, J. L., Wang, J. X., Guo, M. Z., & Zhuang, J.(2018), Design and experiment of pneumatic-mechanical combined precision metering device for soybean, *Transactions of the Chinese Society for Agricultural Machinery*, vol.49, issue 4, pp. 75-86+139; <https://doi.org/10.6041/j.issn.1000-1298.2018.04.009>
- [6] Liao, Y. T., Liao, Q. X., Wang, L., Zheng, J., & Gao, L. P. (2018), Investigation on vacuum singulating effect influencing factors of pneumatic precision seed metering device for small particle size of seeds, *Transactions of the Chinese Society of Agricultural Engineering*, vol.34, issue 24, pp. 10-17; <https://doi.org/10.11975/j.issn.1002-6819.2018.24.002>
- [7] Liu, H. X., Guo, L. F., Fu, L. L., & Tang, S. F. (2015), Study on multi-size seed-metering device for vertical plate soybean precision planter, *International Journal of Agricultural and Biological Engineering*, vol.8, issue 1, pp.1-8; <https://doi.org/10.3965/j.ijabe.20150801.001>
- [8] Liu, Y. Q., Zhao, M. Q., & Hu, Y. W. (2013), Finite element analysis of airflow field for vacuum chamber in air-suction seed metering device of no-till seeder, *Applied Mechanics and Materials*, vol.275-277, pp.547-553; <https://doi.org/10.4028/www.scientific.net/AMM.275-277.547>
- [9] Mao, X., Yi, S. J., Tao, G. X., Yang, L., Liu, H. Y., & Ma, Y. C. (2015), Experimental study on seed-filling performance of maize bowl-tray precision seeder, *International Journal of Agricultural and Biological Engineering*, vol.8, issue 2, pp.31-38; <https://doi.org/10.3965/j.ijabe.20150802.1809>
- [10] Singh, R., Singh, G., & Saraswat, D. (2007), Design and operational parameters of a pneumatic seed metering device for planting of groundnut (*Arachis hypogaea*) seeds, *Indian Journal of Agricultural Sciences*, vol.77, issue 1, pp.40-42.
- [11] Wang, J. W., Tang, H., Wang, J. F., Li, X., & Huang, H. N. (2017), Optimization design and experiment on ripple surface type pickup finger of precision maize seed metering device, *International Journal of Agricultural and Biological Engineering*, vol.10, issue 1, pp. 61-71; <https://doi.org/10.3965/j.ijabe.20171001.2050>
- [12] Xing, H., Zang, Y., Wang, M. Z., Luo, W. X., & Fang, Y. L. (2020), Design and Experimental Analysis of a Stirring Device for A Pneumatic Precision Rice Seed Metering Device, *Transactions of the ASABE*, vol.63, issue 4, pp. 709-808; <https://doi.org/10.13031/TRANS.13096>
- [13] Yang, L., Yan, B. X., Yu, Y. M., He, X. T., Liu, Q. W., Liang, Z. J., Yin, X. W., Cui, T., & Zhang, D. X. (2016), Global overview of research progress and development of precision maize planters, *International Journal of Agricultural and Biological Engineering*, vol.9, issue 1, pp. 9-26.
- [14] Yu, J. J., Liao, Y. T., Cong, J. L., Yang, S., & Liao, Q. X. (2014), Simulation analysis and match experiment on negative and positive pressures of pneumatic precision metering device for rapeseed, *International Journal of Agricultural and Biological Engineering*, vol.7, issue 3, pp. 1-12.
- [15] Yu, H. L., Zhao, X. S., Liu, Z. L., Du, X., & Tian, C. (2015), Study on negative-pressure precision millet seed-metering device, *Advance Journal of Food Science and Technology*, vol.7, issue 2, pp.139-143; <https://doi.org/10.19026/ajfst.7.1282>
- [16] Zhang, G. Z., Zang, Y., Luo, X. W., Wang, Z. M., Zhang, Q., & Zhang, S. S. (2015), Design and indoor simulated experiment of pneumatic rice seed metering device, *International Journal of Agricultural and Biological Engineering*, vol.8, issue 4, pp. 10-18; <https://doi.org/10.3965/j.ijabe.20150804.1626>
- [17] Zhang, K. X., Sun, Y. Y., Liu, L., Liu, X. X., & Zhao, X. Y. (2020), Design and test of variable diameter pneumatic drum type bean seed metering device, *INMATEH - Agricultural Engineering*, vol.60, issue 1, pp.9-18; <https://doi.org/10.35633/INMATEH-60-01>
- [18] Zhao, Z., Wu, Y. F., Yin, J. J., & Tang, Z. (2015). Monitoring method of rice seeds mass in vibrating tray for vacuum-panel precision seeder, *Computers and Electronics in Agriculture*, vol.114, pp.25-31; <https://doi.org/10.1016/j.compag.2015.03.007>