

DESIGN AND EXPERIMENT OF ADJUSTABLE SOCKET-WHEEL PRECISION FERTILIZER APPARATUS FOR DRY DIRECT-SEEDING RICE

可调窝眼轮式旱直播水稻精量穴施排肥器设计与试验

Liu Jun ¹⁾, Zhu Dequan ^{1,2)}, Tai Qilei ¹⁾, Yu Congyang ¹⁾, Wang Tingjue ¹⁾, Xue Kang ¹⁾, Zhang Shun ¹⁾, Liao Juan ¹⁾ ¹

¹⁾ School of Engineering, Anhui Agricultural University, Hefei 230036, China;

²⁾ Anhui Province Engineering Laboratory of Intelligent Agricultural Machinery and Equipment, Hefei 230036, China;

^{*)} Corresponding author, E-mail: zhudequan@ahau.edu.cn

DOI: <https://doi.org/10.356.33/inmateh-63-12>

Keywords: hole fertilization, fertilizer apparatus, socket-wheel, numerical simulation, test

ABSTRACT

To solve problems of non-adjustable fertilizer and low fertilization precision in the precision hole fertilization of dry direct-seeding rice, an adjustable socket-wheel precision hole fertilizer apparatus for rice was designed. The basic structure and working principle of the fertilizer apparatus were expounded, the structural parameters of key components were determined. The numerical simulation experiments based on the discrete element method were carried out by using sulfurized urea as the research object. Selecting the rotation speed of the socket-wheel, the length of the trough, the depth of the socket as the experimental factors, and taking the average amount of fertilizer discharging and the coefficient of variation of fertilization uniformity as evaluation indicators, the orthogonal rotation combined experiments with three factors and five levels were carried out. A multi-objective optimization method was used to determine the best parameter combination under the constraint of the target value of the hole fertilizer discharging of 1.500 g. The simulation results show that the coefficient of variation of fertilizer uniformity was the smallest and the coefficient of variation was 15.80% when the rotation speed of socket-wheel was 26.57 r/min, the length of the trough was 5.36 mm and the depth of socket was 5.64 mm. By using slow-release urea, sulfurized urea and bio-organic fertilizer as test materials, the bench test and field test was carried out on the fertilizer apparatus and the reliability of the simulation results and the adaptability of the fertilizer apparatus were verified.

摘要

针对旱直播水稻精量穴施肥中存在施肥量不可调节、施肥精度低等问题,设计了一种可调窝眼轮式水稻精量穴施排肥器。阐述了排肥器基本结构与工作原理,确定了关键零部件结构参数。以加硫尿素为试验材料,利用离散元法,选取窝眼轮转速、料槽长度、窝眼深度为试验因素,以排肥量均值、排肥均匀性变异系数为评价指标,进行3因素5水平正交旋转组合试验。在穴排肥量目标值为1.500 g的约束条件下,确定了最佳参数组合。仿真结果表明:在窝眼轮转速为26.57 r/min、料槽长度为5.36 mm、窝眼深度为5.64 mm时,排肥均匀性变异系数最小,变异系数为15.80%。以缓释尿素、加硫尿素、生物有机肥为试验材料,对排肥器进行台架验证试验与田间施肥试验,验证了仿真结果的可靠性与排肥器的适应性。

INTRODUCTION

At present, banding and broadcasting are the main ways of fertilization for chemical fertilizer in dry direct-seeding rice, and there are problems such as the over-usage of fertilizer and poor uniformity, which not only affect the yield and quality of rice, but also increase production cost and cause environmental pollution (Zheng et al., 2019, Hu et al., 2020, Wang et al., 2018).

Precision fertilization can effectively improve the utilization rate of fertilizer, reduce the usage of fertilizer, and help improve the yield and quality of rice (Fan et al., 2020, Zhang et al., 2018, Wang et al., 2020, Zhang et al., 2019). Alameen et al. developed a variable fertilization control system for the granular fertilizer, which could automatically set the required fertilizer amount and improve the fertilization accuracy (Alameen et al., 2019). Yang et al. designed a bivariate fertilization machine with an outer groove-wheel, which greatly improved the stability of fertilizer discharging compared with the common outer groove-wheel

¹ Jun liu, As. M.S. Stud. Eng.; Dequan Zhu, Prof. Ph.D. Eng.; Qilei Tai, As. M.S. Stud. Eng.; Congyang Yu, As. M.S. Stud. Eng.; Tingjue Wang, As. Ph.D. Stud. Eng.; Kang Xue, As. Ph.D. Stud. Eng.; Shun Zhang, Lec. Ph.D. Eng.; Juan Liao, Lec. Ph.D. Eng.

fertilizer apparatus (Yang et al., 2019). Xue et al. used EDEM software to simulate the fertilizer discharging process, analysed the movement law of granular fertilizer, and improved the fertilization effect of the spiral fertilizer distributor (Xue et al., 2019). Lei et al. designed a horizontal pneumatic screw combination adjustable quantitative fertilizer feeding device for a granular fertilizer, which improved the performance of fertilizer filling and fertilizer discharging (Lei et al., 2018). Yuan et al. designed a spoon wheel fertilizer applicator, which improved the fertilizer utilization rate and reduced the production cost (Yuan et al., 2018). All the above researches have improved the fertilization performance to a certain extent, but there are still some problems such as non-adjustable fertilizer and low fertilization precision, which are difficult to meet the requirements of precision hole fertilization of dry direct-seeding rice at present.

Therefore, aiming at the problems mentioned above in the hole fertilization process, an adjustable socket-wheel precision hole fertilizer apparatus was designed and the discrete element method was used to evaluate the performance of the fertilizer apparatus. Selecting the rotation speed of the socket-wheel, the length of the trough, the depth of the socket as the experimental factors, and taking the average amount of fertilizer discharging and the coefficient of variation of fertilization uniformity as evaluation indicators, the orthogonal rotation combined experiments with three factors and five levels were carried out. A multi-objective optimization method was used to determine the best parameter combination under the constraint of the target value of the hole fertilizer discharging of 1.500 g. The reliability of the simulation results was verified through bench tests, and the working performance of the fertilizer apparatus was tested through field tests, which can provide a theoretical basis for the structure optimization and performance improvement of the fertilizer apparatus.

MATERIALS AND METHODS

• Structure and working principle

The adjustable socket-wheel precision hole fertilizer apparatus for rice mainly consists of fertilizer shaft, adjustment plate, isolation ring, fertilizer protection belt and others, as shown in Fig.1.

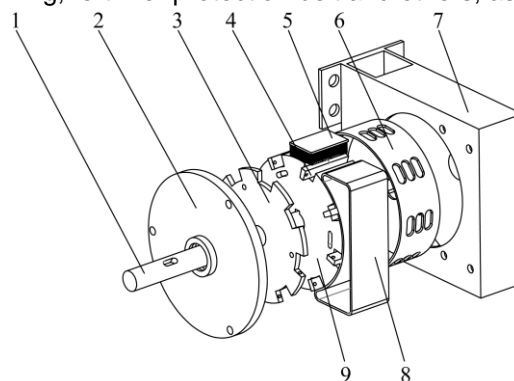

Fig. 1 - Diagram of structure and working principle of fertilizer apparatus

1 – Fertilizer shaft; 2 – Flange; 3 – Adjusting disc; 4 – Adjustment plate; 5 – Brush; 6 – Isolation ring; 7 – Shell; 8 – Fertilizer protection belt; 9 – Socket-wheel

According to the type of fertilizer and the requirement of the amount of rice fertilization, the adjustment disc will be rotated to drive the adjustment plate to move synchronously in the axial direction before working, so as to adjust the volume of the socket to meet the requirement of fertilization. When working, fertilizer will be charged from the fertilizer tank into the fertilizer apparatus firstly, then the fertilizer shaft drives the socket-wheel to rotate, and the fertilizer particles are filled into the socket in the end. In the fertilizer clearing area, excess fertilizer particles are removed by brushes and the fertilizer particles will be fertilized for a second time. In the fertilizer protection area, due to the role of the fertilizer protection belt, the fertilizer particles in the socket will not fall in advance. When reaching the fertilizer discharging area, the fertilizer particles fall into the fertilizer ditch by their gravity and centrifugal force to complete a precision fertilizer discharging operation.

• Design of key component parameters

Design of adjustment plate parameters

To meet the agronomic requirements of different fertilization amounts, an adjusting plate was designed to adjust the volume of the socket. One end of the adjusting plate is in the socket of the socket-wheel, the socket-wheel provided with the material trough communicating with the socket, and the space for containing fertilizer is formed by the material trough and the socket.

The other end of the adjusting plate can slide along the outside of the circle of the sliding groove of the socket-wheel, and the outside of the adjusting plate is flushed with the outside of the socket-wheel. After the position of the adjusting plate has been adjusted, the adjusting plate is fixedly connected with the socket-wheel. To meet the requirements of different types of fertilizer particles and different fertilizer amounts for the fertilizer apparatus, an adjustable trough is set on the side of the hemisphere of the socket. The number of sockets is limited by the distance between the socket-wheel and the socket, and the way to increase the number of sockets is to increase the width of the socket-wheel or to use the three rows of uniform equal distance distribution.

The structure of the adjusting plate is shown in Fig.2.

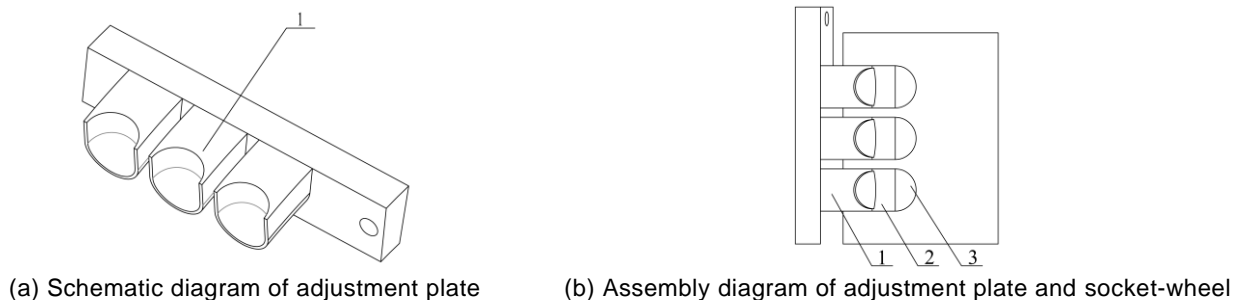

Fig. 2 - Schematic diagram of adjusting plate structure

1 – Adjustment plate; 2 – Trough; 3 – Socket

The material trough of the adjustment plate is installed in conjunction with the socket of the socket-wheel, and the shape of the material trough consists of a hemisphere and a semi-cylinder.

• Design of adjustment plate parameters

To ensure the fertilizer filling performance of the socket and the adaptability of the fertilizer apparatus, three varieties of granular fertilizer of the slow-release urea, sulfurized urea, and bio-organic fertilizer were selected as the study objects. Each variety of fertilizer was randomly selected with 500 grains to measure the triaxial size of the fertilizer particles. The equivalent diameter (D_e) and sphericity rate (ϕ) of the fertilizer particles can be calculated by the formula (1) (Dun et al., 2020).

$$\begin{cases} D_e = (LWT)^{1/3} \\ \phi = \frac{D_e}{L} \times 100\% \end{cases} \quad (1)$$

where:

L is the average length, [mm];

W is the average width, [mm];

T is the average thickness, [mm].

The triaxial size, equivalent diameter and sphericity rate of the three kinds of fertilizer particles are shown in Table 1.

Table 1

Triaxial size, equivalent diameter and sphericity rate of fertilizer particles

Fertilizer varieties	Average length (mm)	Average width (mm)	Average thickness (mm)	Equivalent diameter (mm)	Sphericity rate (%)
Slow-release urea	4.25	4.04	3.83	4.04	95.06
Sulfurized urea	5.39	4.74	4.27	4.78	88.68
Bio-organic fertilizer	4.21	4.10	3.99	4.10	97.39

The fertilizer particles may accumulate in the socket after the fertilizer particles are filled into the socket. Gaps will be formed between fertilizer particles socket and fertilizer particles-fertilizer particles because of the high sphericity rate of fertilizer particles (Zhang et al., 2003). Due to the existence of gaps, the actual volume of the fertilizer in the socket is smaller than the volume of the socket, so the porosity of the fertilizer particles should be considered when designing the socket size. The porosity (ϵ) can be calculated by the formula (2).

$$\left\{ \begin{aligned} \varepsilon &= \frac{v_b}{v_a} \times 100\% \\ v_b &= v_a - v_p \\ v_a &= \frac{m}{\rho_a} \\ v_p &= \frac{m}{\rho_p} \end{aligned} \right. \quad (2)$$

where:

- v_a is the accumulated volume of fertilizer particles, [cm³];
- v_b is the interstitial volume of fertilizer particles, [cm³];
- v_p is the real volume of fertilizer particles, [cm³];
- m is the mass of the accumulated fertilizer particle, [g];
- ρ_a is the density of the accumulated fertilizer particle, [g/cm³];
- ρ_p is fertilizer particle density, [g/cm³].

The porosities and densities of the fertilizer particles of the three varieties are shown in Table 2.

Porosities and densities of fertilizer particles

Table 2

Fertilizer varieties	Slow-release urea	Sulfurized urea	Bio-organic fertilizer
Porosity (%)	43.44	59.23	54.88
Density (g cm ⁻³)	1.214	1.330	1.936

Since the fertilizer particles of the three varieties are all similar to spheres, the shape of the sockets was selected as a circle. The structure parameters of the socket are shown in Fig.3.

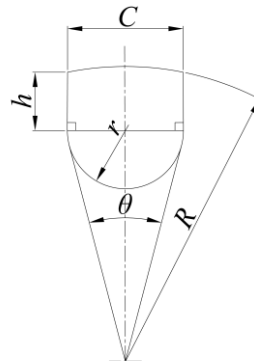

Fig. 3 - Structure parameters of the socket

where:

- h is the depth of the socket, [mm];
- r is the radius of the socket, [mm];
- C is the diameter of the socket, [mm];
- R is the radius of the socket-wheel, [mm];
- θ is the outer arc angle of the socket, [rad].

According to the agronomic requirements of precision hole fertilization of dry direct-seeding rice, the standard of the amount for fertilization was selected to be 285-700 kg/hm². It was calculated that the amount of fertilizer per hole is 0.875-2.150 g.

Assuming that the radius of the fertilizer particles is A [mm], the volume of a single fertilizer particle can be calculated by formula (3).

$$v = \frac{4}{3} \pi A^3 \quad (3)$$

where: v is the volume of fertilizer particles, [mm³].

Due to the different densities of the three kinds of fertilizer particles, the sulfurized urea with moderate density was selected as the research object in the design. The actual volume of fertilizer per hole can be calculated according to formula (4).

$$V_1 = \frac{m_1}{\rho_p} \tag{4}$$

where:

V_1 is the actual volume of fertilizer particles, [mm³];

m_1 is the mass of fertilizer per hole, [g];

ρ_p is the density of fertilizer particle, [g cm⁻³].

It can be calculated by formula (4) that the volume of fertilizer per hole was 0.66-1.62 cm³, and the volume of fertilizer per hole was 0.22-0.54 cm³.

The socket radius was set as 4.5 mm, and V_2 can be calculated by formula (5).

$$V_2 = (51.71\pi + 77.56h\pi + 10.13\pi l + 9hl)(1 - \varepsilon) \tag{5}$$

where:

V_2 is the volume of fertilizer particles in the socket, [mm³];

l is the length of the trough, [mm].

• **Fertilizer discharging performance simulation**

Model building and parameter setting

After the assembly model of the fertilizer apparatus was completed in the SolidWorks, save the model as a .step format document and import it into the EDEM for simulation. A conveyor belt was set directly below the fertilizer outlet, and the direction was horizontal to the left so as to simulate the movement of the ground. A detection device was set directly below the fertilizer outlet to detect the quantity of fertilizer particles discharging from each hole. The process of the simulation was shown in Fig.3. Define the material properties of fertilizer particles, stainless steel, resin and soil (Zhu et al., 2018), respectively, as shown in Table 3.

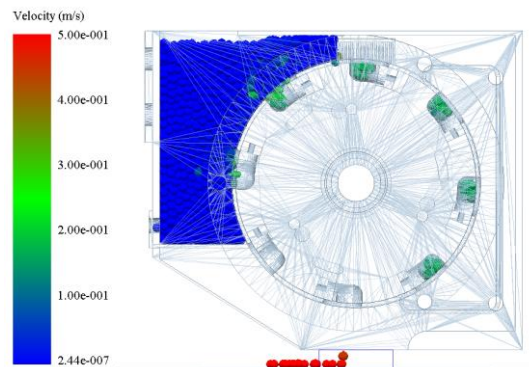

Fig. 4 - Process of simulation

Table 3

Material properties			
Items	Shear modulus (Pa)	Poisson's ratio	Density (kg·m ⁻³)
Fertilizer particles	1×10 ⁷	0.25	1330
Stainless steel	7×10 ¹⁰	0.30	7800
Resin	1.×10 ⁶	0.45	1150
Soil	1.×10 ⁸	0.49	2350

The material contact parameters of fertilizer-fertilizer, fertilizer-resin and fertilizer-soil are shown in Table 4. The simulation time was set as 15 s, and fertilizer particles were generated in 1 s. The value of the fixed time step was set as the 20% in simulation.

Table 4

Material contact parameters			
Items	Coefficient of restitution	Coefficient of static friction	Coefficient of rolling friction
Fertilizer -fertilizer	0.11	0.32	0.24
Fertilizer-resin	0.45	0.28	0.19
Fertilizer-soil	0.04	1.25	1.28

The sphericity of sulfurized urea is greater than 88%, so the sulfurized urea fertilizer particles can be viewed as spheres in the EDEM software. Therefore, the diameter of the sulfurized urea was set as 4.78 mm in the numerical simulation model.

Model building and parameter setting

The average amount of fertilizer discharging (\bar{X}) and the coefficient of variation of fertilizer uniformity (CV) can be calculated by the following formulas (Wang et al., 2018).

$$\bar{X} = \frac{\sum_{i=1}^m X_i}{N} \quad (6)$$

$$CV = \sqrt{\frac{\sum_{i=1}^m (X_i - \bar{X})^2}{(m-1)\bar{X}^2}} \times 100\% \quad (7)$$

where:

X_i is the mass of fertilizer of the i -th hole, [g];

N is the number of holes.

Test factors coding and levels setting are shown in Table 5.

Table 5

Test factors coding and levels setting				
Code	Rotating speed of socket-wheel X_1 (r·min ⁻¹)	Length of trough X_2 (mm)	Depth of socket X_3 (mm)	
1.682	35.00	8.00	7.00	
1	30.94	6.38	6.19	
0	25.00	4.00	5.00	
-1	19.06	1.62	3.81	
-1.682	15.00	0.00	3.00	

• Bench verification tests

Test materials and equipment

The test site was the precision seeding laboratory of Anhui Agricultural University, and the test materials were slow-release urea, sulfurized urea and bio-organic fertilizer. The test equipment was the JPS-12 type seed-metering device performance test bench developed by the Heilongjiang Agricultural Machinery Engineering Research Institute. The fertilizer apparatus was installed on a fixed supporter, and the motor was controlled to drive the fertilizer apparatus device to rotate. The fertilizer bed belt was coated with a certain width of sticky oil, and the fertilizer particles were dropped from the fertilizer apparatus port onto the sticky oil layer. Data was collected through artificial observation and measurement.

The bench test process was shown in Fig.5.



Fig. 5 - Diagram of bench tests

1 – Control console; 2 – Fixed supporter; 3 – Fertilizer apparatus; 4 – fertilizer bed belt; 5 – Motor

• Field fertilization tests

Test materials and conditions

To further test the performance of the fertilizer apparatus, the field fertilization tests were carried out in the agricultural field of Anhui Agricultural University. The test materials were slow-release urea, sulfurized urea and bio-organic fertilizer. Before the tests, a rotary tiller was used to smooth the surface of the test field, and the height difference of the ground in the field after the rotary tillage was within 5 cm.

RESULTS

• Simulation test results

The simulation test results are shown in Table 6.

Table 6

Simulation test results

Codes	Rotating speed of socket-wheel X_1 (r·min ⁻¹)	Length of trough X_2 (mm)	Depth of socket X_3 (mm)	Average amount of fertilizer discharging Y_1 (g)	Coefficient of variation of fertilizer uniformity Y_2 (%)
1	-1	-1	-1	0.678	14.00
2	1	-1	-1	0.732	13.14
3	-1	1	-1	1.102	21.03
4	1	1	-1	1.258	19.87
5	-1	-1	1	0.895	14.50
6	1	-1	1	1.013	13.48
7	-1	1	1	1.535	21.55
8	1	1	1	1.721	20.26
9	-1.682	0	0	1.079	17.00
10	1.682	0	0	1.069	16.48
11	0	-1.682	0	0.725	8.99
12	0	1.682	0	1.702	21.55
13	0	0	-1.682	0.921	17.54
14	0	0	1.682	1.465	19.84
15	0	0	0	1.268	13.78
16	0	0	0	1.266	12.45
17	0	0	0	1.174	12.56
18	0	0	0	1.248	11.95
19	0	0	0	1.159	11.75
20	0	0	0	1.262	13.15
21	0	0	0	1.277	13.25
22	0	0	0	1.123	12.89
23	0	0	0	1.288	12.05

Analysis of simulation results

These regression equations among the experimental factors and the evaluation indicators were obtained by using Design-Expert software to analyse the data in Table 6:

$$\begin{cases} Y_1 = -0.936 + 0.081X_1 + 0.015X_2 + 0.179X_3 + 1.503 \times 10^{-3} X_1X_2 \\ \quad + 1.622 \times 10^{-3} X_1X_3 + 0.018X_2X_3 - 1.788 \times 10^{-3} X_1^2 - 2.431 \times 10^{-3} X_2^2 - 0.015X_3^2 \\ Y_2 = 71.965 - 2.089X_1 + 0.279X_2 - 14.728X_3 - 5.040 \times 10^{-3} X_1X_2 \\ \quad - 5.128 \times 10^{-3} X_1X_3 + 3.089X_2X_3 + 0.041X_1^2 + 0.166X_2^2 + 1.519X_3^2 \end{cases} \quad (8)$$

The analysis of variance of model variables are shown in Table 7.

Table 7

Variance analysis of model variables

Source of variation	Average amount of fertilizer discharging				Coefficient of variation of fertilizer uniformity			
	Sum of squares	Degree of freedom	F value	P value	Sum of squares	Degree of freedom	F value	P value
Model	1.64	9	47.59	<0.0001	298.23	9	83.64	<0.0001
X_1	0.018	1	4.72	0.0489*	1.98	1	5.01	0.0434*
X_2	1.14	1	296.47	<0.0001**	173.76	1	438.56	<0.0001**
X_3	0.39	1	101.75	<0.0001**	2.31	1	5.83	0.0312*
X_1X_2	3.613×10^{-3}	1	0.94	0.3496	0.041	1	0.10	0.7539
X_1X_3	1.105×10^{-3}	1	0.29	0.6006	0.011	1	0.027	0.8731
X_2X_3	0.020	1	5.16	0.0407*	6.125×10^{-4}	1	1.546×10^{-3}	0.9692
X_1^2	0.063	1	16.49	0.0014**	33.94	1	85.66	<0.0001**
X_2^2	3.012×10^{-3}	1	0.79	0.3917	14.09	1	35.57	<0.0001**
X_3^2	7.018×10^{-3}	1	1.83	0.1993	73.51	1	185.54	<0.0001**
Residual	0.050	13			5.15	13		
Lack of fit	0.021	5	1.12	0.4192	1.50	5	0.66	0.6664
Pure error	0.029	8			3.65	8		
Total	1.69	22			303.38	22		

Note: The “***” indicates the highly significance at 0.01 level; the “**” indicates significance at 0.05 level.

According to the analysis of Table 7, it can be obtained that the order of the model variables affecting the average amount of fertilizer discharging was as follows: $X_2 > X_3 > X_1^2 > X_2X_3 > X_1 > X_3^2 > X_1X_2 > X_2^2 > X_1X_3$. Among these model variables, X_2 , X_3 , and X_1^2 all have a very significant impact, X_2X_3 and X_1 both have a significant impact. It can be obtained that the order of the model variables affecting the coefficient of variation of fertilizer uniformity was as follows: $X_2 > X_3^2 > X_1^2 > X_2^2 > X_3 > X_1 > X_1X_2 > X_1X_3 > X_2X_3$. Among these model variables, X_2 , X_3^2 , X_1^2 and X_2^2 all have a very significant impact, X_3 and X_1 both have a significant impact.

In order to more intuitively analyse the relationship between influencing factors and the performance of the fertilizer apparatus, the response surface graphs were obtained by processing the data of the orthogonal test, as shown in Fig. 6.

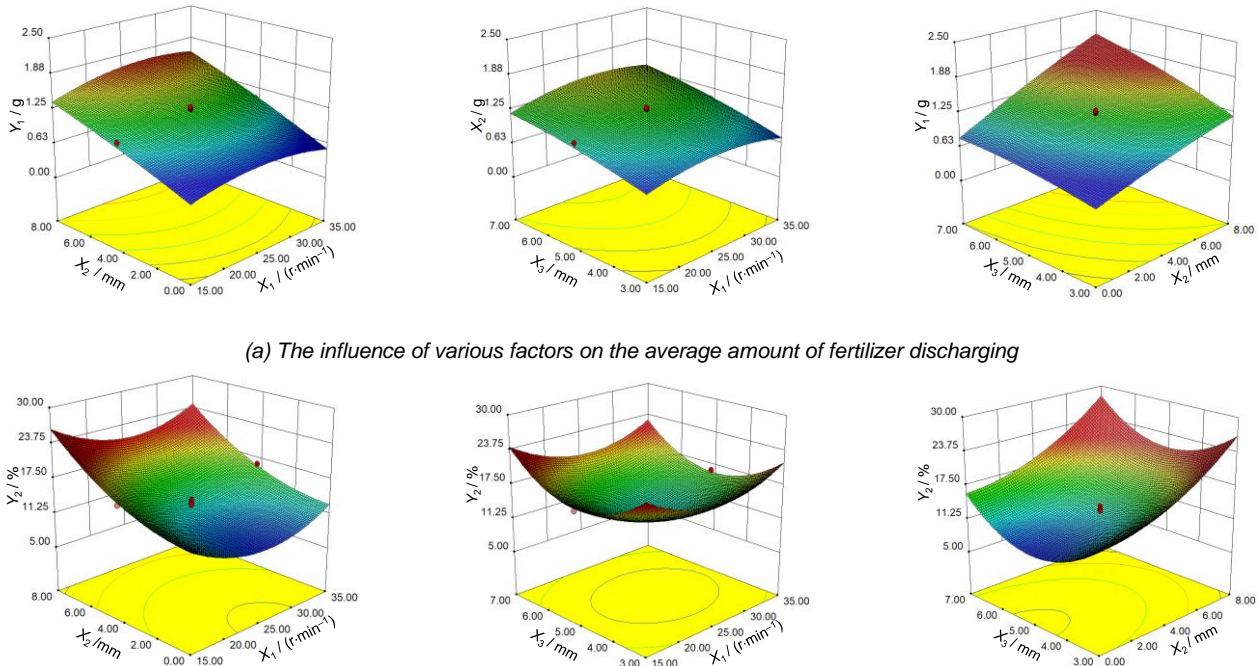

(a) The influence of various factors on the average amount of fertilizer discharging

(b) The influence of various factors on the coefficient of variation of fertilizer uniformity

Fig. 6 - Influences of various factors on evaluation indexes

It can be seen from Fig.6(a) that the average amount of fertilizer discharging increases with the increase of the trough length, and increases with the increase of the socket depth. When the length of the trough and the depth of the socket increase, the volume of the socket increases, the average amount of fertilizer discharging particles filled into the socket increases. It can be seen from Fig.6(b) that the coefficient of variation of fertilizer uniformity first decreased and then increased with the increase of the socket depth when trough length was constant. When the socket depth is too large, the time for the fertilizer particles to fall increases, which results in an increase in the coefficient of variation of fertilizer uniformity. When the socket depth is constant, the coefficient of variation of fertilizer uniformity increases with the trough length. When the trough length increases, some of the fertilizer particles do not fill the socket in time, resulting in an increase in the coefficient of variation of fertilizer uniformity.

Simulation parameter optimization

During the fertilization process, the coefficient of variation of fertilizer uniformity is as better as small. The parameters were optimized at the target value of the hole fertilizer discharging of 1.500 g, and the constraints were shown as formula (9).

$$\begin{cases} 15.00 \text{ r/min} \leq X_1 \leq 35.00 \text{ r/min} \\ 0.00 \text{ mm} \leq X_2 \leq 8.00 \text{ mm} \\ 3.00 \text{ mm} \leq X_3 \leq 7.00 \text{ mm} \\ 0.875 \text{ g} \leq Y_1(X_1, X_2, X_3) \leq 2.105 \text{ g} \\ 0 \leq Y_2(X_1, X_2, X_3) \leq 40\% \end{cases} \quad (9)$$

According to the constraint model, the Design-Expert software was used to optimize the solution, and obtain the optimal parameter combination that affects the coefficient of variation of fertilizer uniformity. When the rotating speed of the socket-wheel was 26.57 r/min, the trough length was 5.36 mm and the socket depth was 5.64 mm, the coefficient of variation of fertilizer uniformity was the smallest, with a value of 15.80%.

- **Bench verification results**

The fertilizer apparatus worked under the conditions of the optimal parameters combination obtained by the simulation test, and the mass of each hole of fertilizer discharging per 15 s was measured. The test was repeated three times in each group and the average values were taken as the results. The results are shown in Table 8.

Table 8

Test results of the bench		
Fertilizer varieties	Average amount of fertilizer discharging Y_1 (g)	Coefficient of variation of fertilizer uniformity Y_2 (%)
Slow-release urea	1.739	17.35
Sulfurized urea	1.472	16.40
Bio-organic fertilizer	2.216	15.29

From Table 8, it can be seen that sulfurized urea has the lowest average amount of fertilizer discharging, while bio-organic fertilizer has the highest average amount of fertilizer discharging. Bio-organic fertilizer has the lowest coefficient of variation of fertilizer uniformity, while sulfurized urea has the highest coefficient of variation of fertilizer uniformity. The error between the bench test results and the simulation parameter optimization results was less than 5%, so the simulation results were reliable.

- **Field fertilization results**

The structure parameters of the fertilizer apparatus were the optimal parameters, and the traveling speed of the walking tractor was about 3.6 km/h. The quality of 50 holes of fertilizer was counted consecutively for each group of trials, and each trial was repeated three times. The results are shown in Table 9.

Table 9

Test results of the field		
Fertilizer varieties	Average amount of fertilizer discharging Y_1 (g)	Coefficient of variation of fertilizer uniformity Y_2 (%)
Slow-release urea	1.750	19.75
Sulfurized urea	1.512	18.44
Bio-organic fertilizer	2.168	17.86

From Table 9, it can be seen that the average amount of fertilizer discharging of the three types of fertilizers was different from the bench test results due to the influence of field vibration on the working performance of the fertilizer apparatus, which cause the changing of the fluidity the irregularly movement of fertilizer particles. Field vibration also led to the instability of the fertilizer particles filling and increased the coefficient of variation of fertilizer uniformity, which was higher than the results of the bench test.

CONCLUSIONS

(1) In order to solve problems of non-adjustable fertilizer and low fertilization precision in the precision hole fertilization of dry direct-seeding rice, an adjustable socket-wheel precision hole fertilizer apparatus for rice was designed. According to the working performance requirements of the fertilizer apparatus, the structural parameters of the key components of the adjustment plate and the socket were determined.

(2) Sulfurized urea was selected as the test material, and the EDEM software was used to simulate the process of the fertilizer discharging in the three factors and five levels of orthogonal rotation combination test. The simulation results were optimized under the conditions that the target value of the hole fertilizer discharging of 1.500 g, the rotating speed of socket-wheel was 26.57 r/min, the depth of socket was 5.36 mm, and the depth of socket was 5.64 mm, and obtained the coefficient of variation of fertilizer uniformity was 15.80%.

(3) The bench test results showed that the average amount of fertilizer discharging of slow-release urea, sulfurized urea and bio-organic fertilizer were 1.739 g, 1.472 g and 2.216 g, respectively,

and the coefficient of variation of fertilizer uniformity were 17.35%, 16.40%, and 15.29%, respectively. Field test results showed the average amount of fertilizer discharging of slow-release urea, sulfurized urea and bio-organic fertilizer were 1.750 g, 1.512 g and 2.168 g, respectively, and the coefficient of variation of fertilizer uniformity were 19.75%, 18.44%, and 17.86%, respectively. The coefficient of variation of fertilizer uniformity of the three varieties of fertilizers were all less than 20% whether the bench test or the field test, which met the requirements of the precision hole fertilization of dry direct-seeding rice, and the fertilizer apparatus had good adaptability to different varieties of granular fertilizers.

ACKNOWLEDGEMENT

This work was supported by the Scientific and Technological Special Project of Anhui Province (No. 17030701045) and the Funding Project of Scientific Research Activities for Academic and Technical Leaders and Reserve Candidates in Anhui Province (No. 2019D223).

REFERENCES

- [1] Alameen, A. A., Al-Gaadi, K. A., Tola, E. (2019), Development and performance evaluation of a control system for variable rate granular fertilizer application, *Computers and Electronics in Agriculture*, vol. 160, pp.31-39;
- [2] Dun, G., Yu, C., Guo, Y., et al. (2020), Design and Experiment of double-gear type fertilizer apparatus, *Transactions of the Chinese Society for Agricultural Machinery*, vol. 51, issue 3, pp. 87-96;
- [3] Fan, J., Lu, X., Gu, S., et al. (2020), Improving nutrient and water use efficiencies using water-drip irrigation and fertilization technology in Northeast China, *Agricultural Water Management*, vol. 241, article. 106352;
- [4] Hu, J., He, J., Wang, Y., et al. (2020), Design and study on lightweight organic fertilizer distributor, *Computers and Electronics in Agriculture*, vol. 169, article. 105149;
- [5] Lei, X., Li, M., Zhang, L., et al. (2018), Design and experiment of horizontal pneumatic screw combination adjustable quantitative fertilizer feeding device for granular fertilizer, *Transactions of the Chinese Society of Agricultural Engineering*, vol. 34, issue 19, pp. 9-18;
- [6] Wang, J., Gao, G., Wang, J., et al. (2018), Design and test of adjustable blades side deep fertilizing device for paddy field, *Transactions of the Chinese Society for Agricultural Machinery*, vol. 49, issue 03, pp. 68-76;
- [7] Wang, J., Li, R., Zhang, H., et al. (2020), Beneficial bacteria activate nutrients and promote wheat growth under conditions of reduced fertilizer application, *BMC Microbiology*, vol. 20, issue 1, pp. 1-12;
- [8] Xue, Z., Zhao, L., Wang, F., et al. (2019), Performance simulation test of the spiral fertilizer distributor based on discrete element method, *Journal of Hunan Agricultural University (Natural Sciences)*, vol. 45, issue 5, pp. 548-553;
- [9] Yang, H., Zhang, L., Dong, W., et al. (2019), Analysis and experiment of fertilizer device for bivariate fertilizer based on discrete element method, *Machine Design and Research*, vol. 35 (5), pp. 179-183;
- [10] Yuan, W., Li, K., Jin, C., et al. (2018), Design and experiment of hill placement fertilizer applicator, *Journal of Agricultural Mechanization Research*, vol. 40, issue 1, pp. 145-149+165;
- [11] Zhang, J., Hou, S., Wang, R., et al. (2018), Design of variable-rate liquid fertilization control system and its stability analysis, *International Journal of Agricultural and Biological Engineering*, vol. 11, issue 1, pp. 109-114;
- [12] Zhang, J., Liu, G., Luo, C., et al. (2019), MOEA/D-DE based bivariate control sequence optimization of a variable-rate fertilizer applicator, *Computers and Electronics in Agriculture*, vol.167, art. 105063;
- [13] Zhang, Y., Hu, Y. (2003), Study on measurement method of porosity of friction material, *Non-Metallic Mines*, vol.26, issue 3, pp. 48-51;
- [14] Zheng, W., Jiang, Y., Ma, X., et al. (2019), Development of a liquid-jet nozzle for fertilizer injection in paddy fields using CFD, *Computers and Electronics in Agriculture*, vol. 167, article. 105061;
- [15] Zhu, Q., Wu, G., Chen, L., et al. (2018), Influences of structure parameters of straight flute wheel on fertilizing performance of fertilizer apparatus, *Transactions of the Chinese Society of Agricultural Engineering*, vol. 34, issue 18, pp. 12-20.