

RESULTS OF THE NUTRITIONAL PRESERVATION RESEARCH OF THE ALFALFA LAYING ON STORAGE WITH TWO-PHASE COMPACTION

/

РЕЗУЛЬТАТИ ДОСЛІДЖЕННЯ ЗБЕРЕЖЕНОСТІ ПОЖИВНИХ РЕЧОВИН ЛЮЦЕРНИ ПРИ ЗАКЛАДЦІ НА ЗБЕРІГАННЯ МЕТОДОМ ДВОСТАДІЙНОГО УЩІЛЬНЕННЯ

Milko D.O.¹⁾, Sclyar O.H.¹⁾, Sclyar R.V.¹⁾, Pedchenko G.P.¹⁾,
Zhuravel D.P.¹⁾, Bratishko V.V.²⁾

¹⁾ Dmytro Motornyi Tavria State Agrotechnological University / Ukraine

²⁾ National University of Life and Environmental Sciences of Ukraine / Ukraine

*E-mail: milkodmitry@gmail.com

DOI: <https://doi.org/10.35633/inmateh-60-30>

Keywords: *coefficients of nutrients preservation, procurement of fodder, storing of alfalfa, cost of fodder procurement.*

Abbreviations: *CP.CFi – crude fibre preservation coefficient; CP.CP – crude protein preservation coefficient; CP.NFE – nitrogen-free extracts preservation coefficient; CP.CF – crude fat preservation coefficient.*

ABSTRACT

In modern manufacturing of livestock production, the outstanding value is allocated for a food supply. The main criterion for evaluating the quality of feed components is the nutrient content of the feed ration. However, in the process of the storage, the maintenance of the nutritious substances decreases for various reasons that are leading to decreasing livestock efficiency and increasing the cost. The results of the use of a two-phase compaction of the forage vegetable components on the example of the alfalfa are given in the article. The dependence coefficient of the nutritional preservation on density of the alfalfa put on storage are also presented in this article.

The applied method and the results obtained can be used in the development and design offices to create new equipment based on the two-phase compaction of the fodder vegetable component mixes by preparing them for storage.

The application of this method brings to decreasing losses of nutrients in the storage process which reduces the components cost in total with increasing additional weights and the milk productivity.

АНОТАЦІЯ

У сучасному промисловому виробництві продукції тваринництва видатне значення відводиться на кормову базу. Основним критерієм оцінки якості кормових компонентів є вміст поживних речовин у кормовому раціоні. Однак в процесі зберігання вміст поживних речовин знижується з різних причин, що призводить до зниження продуктивності тварини і підвищення собівартості продукції. У статті наведені результати використання двохстадійного ущільнення рослинних компонентів кормів на прикладі люцерни. Також представлені залежності коефіцієнтів збереження поживних речовин від щільності закладеної на зберігання люцерни. Використаний метод і отримані результати можуть бути використані в розробках конструкторських бюро для створення нової техніки заснованої на двохстадійному ущільненні рослинних компонентів кормових сумішей при заготівлі їх до зберігання. Застосування даного методу призводить до зниження втрат поживних речовин в процесі зберігання, що зменшує витрати на заготівлю компонентів в сукупності з підвищенням приростів і надоїв.

INTRODUCTION

The preservation of nutrients in feed crops in the storage process is of great importance affecting the vital functions of the livestock, their productivity and the quality of the obtained products (*Liu et al., 2018; Mikula et al., 2018; Katsande et. al., 2019*). To a large extent the preservation of the feed components depends on the conditions of their storage and compacting (*Wang et al., 2010; Santos et al., 2016*).

Taking into account the peculiarities of the voluminous fodder structure, it should be noted that in order to achieve the high-quality plant raw materials indices when laying in storage the degree of the compaction is of particular importance. It is also necessary to take note of the effect of the residual relaxation which occurs after the removal of the load and, as a result, a retraction of the oxygen in the air mixtures which leads to the negative consequences namely to the oxidative processes that increase in general the nutritional value of canned food (McCormick *et al.*, 2011; Maraldi *et al.*, 2016; Coblenz *et al.*, 2015, 1996; Stoškus *et al.*, 2019). As a result of the dairy cows activity, alcohols and other oxygen-containing forms are released as well. Lower concentrations of highly reactive alkenes and aldehydes were also detected (Malkina *et al.*, 2011).

MATERIAL AND METHODS

The technology of a two-phase compaction is realized by a constructive technological line which is shown in Fig.1, a. It allows to decrease the relaxation effect after removal and find the way out from a current situation. Two-phase compaction technology increases the quality of the feed preservation and declines its cost. An experimental installation of the two-phase compaction line is shown in Fig.1, b.

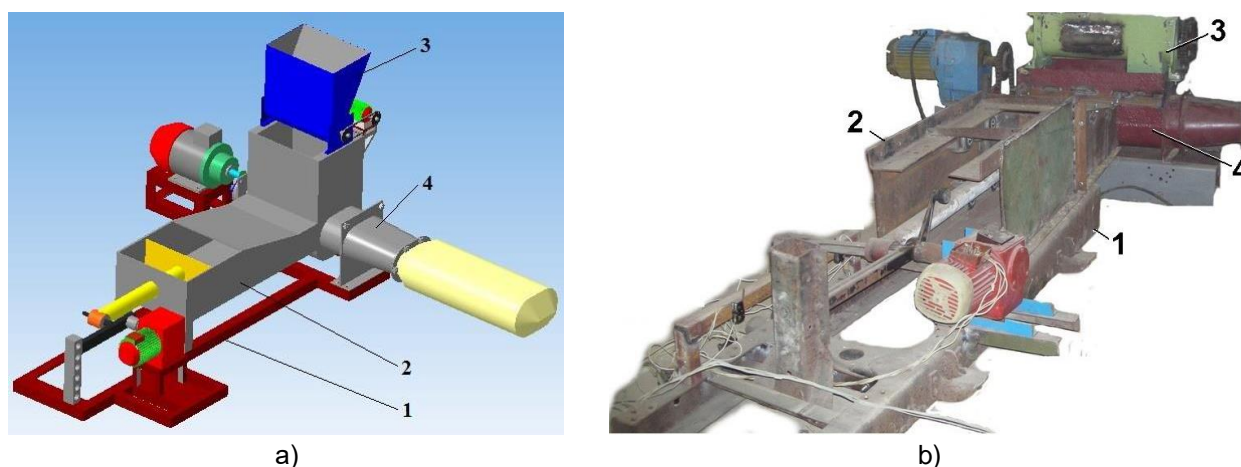

Fig.1 – Laboratory unit

a) Structural diagram b) Main view

1 – frame; 2 – squeezer of preliminary compaction of plant mass; 3 – dozer of preservatives; 4 – twin-screw compactor

The research is based on revealing the influence of the constructive and technological parameter line on the quality indicators of the preserved plant raw materials and on comparing them with the traditional harvesting and storage methods.

The laboratory installation consists of the squeezer of a preliminary compaction, 2, (first phase of compaction) and a two-screw compactor 4, which are mounted on the frame 1. At the same time on the two-screw compactor is mounted a dozer of free-flowing preservatives, 3. The installation will be started by the asynchronous electric motors. The drive mechanism of the preliminary compaction squeezer is a screw, a dozer of preservatives and the two-screw compactor are positioned catenary. The piston sizes of the preliminary compaction squeezer were 300x400 mm, with the stroke of the piston 700 mm. The diameter of the screws was 150 mm, the length was 800 mm and the overlap value was 50 mm. The diameter of the dosing drum was 200 mm, with a cell diameter of 3 mm and a depth of 1.5 mm. The alfalfa in the flowering phase was used during the experiment.

The preservation quality of plant materials after two months of storage was investigated. The combustion heat, total nitrogen and crude fibre were measured.

RESULTS AND DISCUSSION

The ash-content research solution is presented in Fig. 2 and the results are given in Table 1. As a result of carrying out the chemical analyses, combustion heat of vegetable raw material samples was defined and the results are given in Table 2.

According to the Kjeldahl method, the presented samples of plant materials were analyzed for the content of crude fat, crude fiber and total nitrogen.

Table 1

The results of carrying out chemical analyses on the determination of vegetable raw materials ash-content

Sample no.	Mass of crucible [g]	Mass of crucible with hitch [g]	Mass of crucible with hitch after desiccation [g]	Mass of hitch [g]	Mass of ash [g]	Ash-content [%]	Average ash-content [%]
Medick condensed after storage							
1	87.7602	90.8674	88.4526	3.1072	0.6924	22.28	18.97
2	90.4581	93.4624	91.0020	3.0043	0.5439	18.10	
3	78.4418	81.6450	78.9714	3.2032	0.5296	16.53	

The results of the experiments proved that the crude fat content in the samples made up 2.25% as it was determined by the Soxhlet method.

Table 2

The results of carrying out chemical analyses on the plant materials combustion heat definition

Sample no.	Hitch, n [g]	Normal of Mohr's salt, K	Control, [ml]	Volume of solution of Mohr's salt for the sample [ml]	Heat of combustion, Q [kcal/g]	Heat of combustion. Average value Q_{ave} [kcal/g]
1	0.0250	24.6	51.4	24.3	4.05	4.047
2	0.0227			24.6	4.01	
3	0.0212			25.5	4.08	



a)



b)



c)

Fig. 2 – Carrying out chemical researches on ash-content measurements

a) drying of samples; b) burning of samples in the muffle furnace; c) cinder remains

The results of the vegetable raw materials researches on the crude cellulose content are presented in Table 3.

Table 3

The results of carrying out chemical analyses on the crude cellulose content determination

Sample no.	Hitch, n [g]	Normal of Mohr's salt, K	Control, [ml]	Volume of solution of Mohr's salt for the sample [ml]	Content of crude fibre [%]	Average value [%]
1	0.0510	24.6	48.5	36.4	16.01	20.22
2	0.0511			31.0	23.12	
3	0.0552			30.9	21.52	

Due to chemical expertise, the content of total nitrogen was determined, and the results of these tests are given in Table 4.

Table 4

The results of carrying out chemical analyses on the total nitrogen content determination

Sample no.	Variant 1	Variant 2	Variant 3	Average value	Delta	Content of nitrogen [%]	Average content of nitrogen [%]
Alfalfa condensed after harvesting							
1	2.8	2.6	2.7	2.70	3.13	2.44	2.45
2	2.6	2.8	2.8	2.73	3.10	2.41	
3	2.6	2.6	2.7	2.63	3.20	2.49	
Control	5.8	5.8	5.9	5.83	-	-	-

Process of carrying out the titration of the surplus of the sulfuric acid alkali solution is presented in Fig.

3.



Fig. 3 – The process of determining the total nitrogen content by titration

CONCLUSIONS

The chemical composition analysis of the fodder material was carried out in the Dmytro Motornyi Tavria State Agrotechnological University chemical laboratory. The results of the nutrient preservation depending on feed density (extent of compaction) are presented in Fig.4.

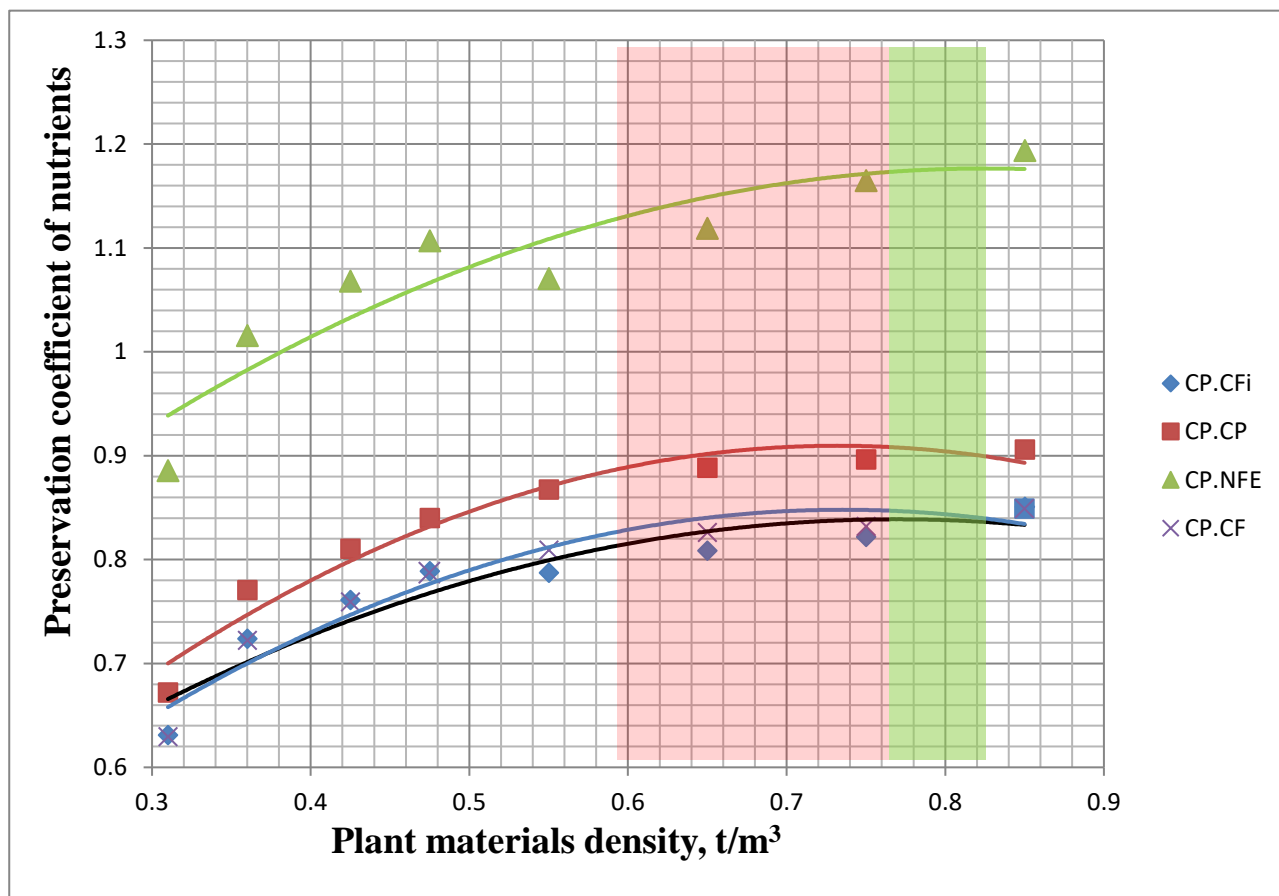

Fig. 4 – Results of determination of plant materials safety coefficients

On the basis of the vegetable raw materials chemical analysis put in the polymeric storages on the offered technology, the following data were obtained: the content of the crude fat (CF) was 2.25% by definition of the Soxhlet extractor, the crude fibre content (CFi) was 20.22%, the crude protein content (CP) was 14.5%. The submitted data confirm a high quality of the received fodder weight. Also, the high quality confirmed the production tests in the farms of the Zaporizhia and Kherson regions.

The data obtained show, that the degree of compaction of plant materials has an optimum, being at the level of 0.78 - 0.82 t/m³. As the density of plant materials increases during packing, there is a destruction of its cellular structure, which means disintegration and oxidation of nutrients. On the contrary, at the insufficient compaction, a considerable development of the pathogenic micro flora occurs which leads to the development of putrefactive and other anaerobic bacteria.

ACKNOWLEDGMENTS

The authors thank the chemical laboratory staff of the University of the Dmytro Motornyi Tavria State Agrotechnological University for assistance with plant materials preparing and chemical analysis.

REFERENCES

- [1] Coblenz W.K., Fritz J.O. and others, (1996), Quality Changes in Alfalfa Hay During Storage in Bales. *Journal of Dairy Science*, Vol. 79, No. 5, pp. 873-885.
- [2] Coblenz, W.K., Coffey K.P. and others, (2015), Storage characteristics, nutritive value, and fermentation characteristics of alfalfa packaged in large-round bale sand wrapped in stretch film after extended time delays. *Journal of Dairy Science*, Vol. 99, No. 5, pp. 1-15.

- [3] Katsande S., Baloyi J.J. and others, (2019), Rumen degradability of selected forage legumes using the in Sacco nylon bag technique. *Animal Nutrition and Feed Technology*, Vol. 19, No. 1, pp. 57-63.
- [4] Liu Q., Wang C. and others, (2018) Effects of dietary protein level and rumen-protected pantothenate on nutrient digestibility, nitrogen balance, blood metabolites and growth performance in beef calves. *Journal of Animal and Feed Sciences*, Vol. 27, No. 3, pp. 202-210.
- [5] Malkina I.L., Kumar A. and others, (2011), Identification and quantitation of volatile organic compounds emitted from dairy silages and other feedstuffs. *Journal of Environmental Quality*, Vol. 40, pp. 28-36.
- [6] Maraldi M., Molari L. and others, (2016), Method for the characterization of the mechanical behaviour of straw bales. *Bio systems engineering*, Vol. 151, pp. 141 -151.
- [7] McCormick M.E., Han K.J. and others, (2011), Forage conservation efficiency and lactation response to bahia grass conserved as barn-stored hay, outdoor-stored hay, or baleage. *Journal of Dairy Science*, Vol. 94 No. 5, pp. 2500-2507.
- [8] Mikuła R., Pruszyńska-Oszmałek E. and others, (2018), Effect of different pre-calving feeding strategies on the metabolic status and lactation performance of dairy cows. *Journal of Animal and Feed Sciences*, Vol. 27, No. 4, pp. 292-300.
- [9] Stoškus R., Jatkauskas J. and others, (2019), The effect of mixed bacterial inoculant on the microbial population and aerobic stability of lucerne and maize baleage. *Journal of Animal and Feed Sciences*, Vol. 28, No. 4, 383-391.
- [10] Santos M.C., L. Kung Jr. (2016), The effects of dry matter and length of storage on the composition and nutritive value of alfalfa silage. *Journal of Dairy Science*, Vol. 99 no. 7, pp. 1-4.
- [11] Wang J., Wang, J.Q. and others, (2010), Effect of storing total mixed rations anaerobically in bales on feed quality. *Animal Feed Science and Technology*, Vol 161, pp. 94-102.