

**MODIFICATION OF TWO WHEEL TRACTOR HANDLEBAR  
FOR EASE OF CLIMBING FIELDS SLOPE**  
/  
**MODIFIKASI SETANG KEMUDI TRAKTOR TANGAN UNTUK KEMUDAHAN  
MENDAKI LERENG**

**Cebro Irwin Syahri<sup>1,2\*)</sup>, Mandang Tineke<sup>2)</sup>, Hermawan Wawan<sup>2)</sup>, Desrial<sup>2)</sup><sup>1</sup>**

<sup>1)</sup> Department of Mechanical Engineering, Lhokseumawe State Polytechnic / Indonesia

<sup>2)</sup> Department of Mechanical and Biosystem Engineering, Bogor Agricultural University / Indonesia

\*E-mail: [irwincst@yahoo.com](mailto:irwincst@yahoo.com)

DOI: <https://doi.org/10.35633/inmateh-58-32>

**Keywords:** *adjustable handlebar, two-wheel tractor, modification, slope climbing*

## ABSTRACT

*The use of two-wheel tractors to cultivate terraced rice fields is still experiencing difficulties, especially the complexity of mobilization and the problem of moving the tractor from the lower plots to the upper plots that must climb the steep embankment. This study aims to improve the performance of two-wheel tractors when climbing the slopes, by modifying the handlebar. Modified tractor handlebar can be hoisted with a locking hinge mechanism so that the handlebar angle of inclination to normal position can be adjusted to 0°, 10°, 20°, 30°, and 40°. Simulation of the tractor's handlebar position when starting up the slope was done using AutoCAD software. Modified two-wheel tractors were tested for the ease of climbing the slope, and compared to the tractor with a rigid handlebar. The results of the performance test showed that the adjustable handlebar could climb the slope of 45° and 57° slope angle, while the tractor with fixed handlebar failed to climb. When starting up the slope, the position of the operator can remain standing (not necessarily bending) when operating the two-wheel tractor with the adjustable handlebar. The tractor with adjustable handlebar could climb slopes better and easier than the tractor with the fixed handlebar.*

## ABSTRAK

*Penggunaan traktor roda dua untuk mengolah sawah berteras masih mengalami kendala, terutama sulitnya mobilisasi dan sulitnya memindahkan traktor dari petakan bawah ke petakan atas yang harus mendaki pematang yang curam. Penelitian ini bertujuan meningkatkan kinerja traktor roda dua saat mendaki lereng, dengan memodifikasi stang kemudinya. Stang traktor modifikasi dapat diangkat-tekuk dengan mekanisme engsel yang dilengkapi pengunci, sehingga sudut stang terhadap posisi normal dapat diatur 0°, 10°, 20°, 30°, dan 40°. Simulasi posisi stang traktor saat mulai mendaki lereng dilakukan menggunakan software AutoCAD. Traktor roda dua yang dimodifikasi stangnya diuji kinerja kemudahan pendakian lerengnya, dan dibandingkan dengan traktor dengan stang tanpa engsel. Hasil pengujian kinerja menunjukkan bahwa stang berengsel dapat mendaki lintasan lereng 45° tinggi 150 cm serta lintasan lereng 57° tinggi 120 cm, sedangkan stang tanpa engsel gagal mendaki. Saat memulai mendaki lereng, posisi operator dapat tetap berdiri (tidak harus membungkuk) saat mengoperasikan traktor roda dua dengan stang berengsel. Traktor dengan stang berengsel dengan sudut stang disesuaikan kemiringan lereng, lebih baik kinerjanya dibandingkan dengan stang tanpa engsel.*

## INTRODUCTION

To date, static stability, which in itself has unexpected complexities depending on the design of the vehicle, is understood better than dynamic stability (Hunter, 1993; Ni et al., 2019; Mocanu and Hermenean, 2010). The use of two-wheel tractor to cultivate terraced rice fields is still experiencing difficulties, compared to the use of hand tractors in corn cultivation (Shi, 2015; Sitorus et al., 2017), especially the challenge of tractor mobilization because it is generally located on the hillside with steepness between 15-65%, in addition to the form of plots on the terraces which are usually irregular and narrow-sized, requiring that the two-wheel tractor be specially designed to deal with it (Cebro and Hermawan, 2006; Potau et al., 2011; Edlund et al., 2013; Cebro and Sitorus, 2019).

<sup>1</sup> Cebro Irwin Syahri, Ph.D.Stud.; Mandang Tineke, Prof. Dr.; Hermawan Wawan, Dr.; Desrial, Dr.

Another obstacle is the difficulty of moving a tractor from a patch of rice fields to a patch above it on a steep area. The front of the tractor hit the slope before the tractor wheel reached the slopes of the rice field, so it was difficult to climb the slopes (Kumar and Raheman, 2015). Then, if the front of the two-wheel tractor lifted by the steering handlebars pushed down, the handlebar will be in contact with the ground and difficult to control (Fabbri et al., 2017). This condition causes inconvenience when operating the tractor while climbing the slopes of the rice field. Likewise, while in the position of climbing the slopes of the rice field, it is still difficult to control the motion of a two wheel tractor.

One way to overcome that problem is to modify the structure of the two-wheel tractor section, which allows the tractor wheel to easily touch and grip on the sloped wall with the position of the handlebar comfortably controlled. Then, while climbing and crossing the embankment, it is still comfortably controlled. Several parts may be modified for this purpose, including raising the engine support frame, reversing the engine position, increasing the wheel diameter size, using an adjustable handlebar steering angle, or a combination thereof. The proposal needs to be evaluated for the best selection to be made and continued to be designed and implemented. By modifying the steering handlebar structure of a two-wheel tractor, it is expected to support the ability of the tractor to cross or climb the slopes of the terraced rice fields.

To modify the handlebar structure of the two-wheel tractor to improve the ease of control and the performance of the two-wheel tractor while climbing the terraced rice field slopes, evaluation of several modification proposals is required. It is necessary to choose the best modification concept, which meets the design criteria specified. Changes in the steering handlebar structure will have an impact on the performance of the tractor, so it needs to be carefully evaluated. Furthermore, it is necessary to design the analysis to obtain a strong modular structure to withstand loads, comfortably controlled, and improve climbing ability, but to not reduce the performance when processing the soil. Therefore, the purpose of this study is to improve the performance of the two-wheel tractor climbing the slope, by modifying the steering wheel construction.

**MATERIALS AND METHODS**

***The design process of an adjustable handlebar***

This study used a functional and structural design approach with stages: 1) identification of problems, needs and design criteria designation, 2) development and evaluation of design concepts, 3) design analysis and engineering drawing, 4) prototyping, and 5) functional testing and performance (Fig. 1). Repair steps are carried out if the test results do not meet the design criteria specified.

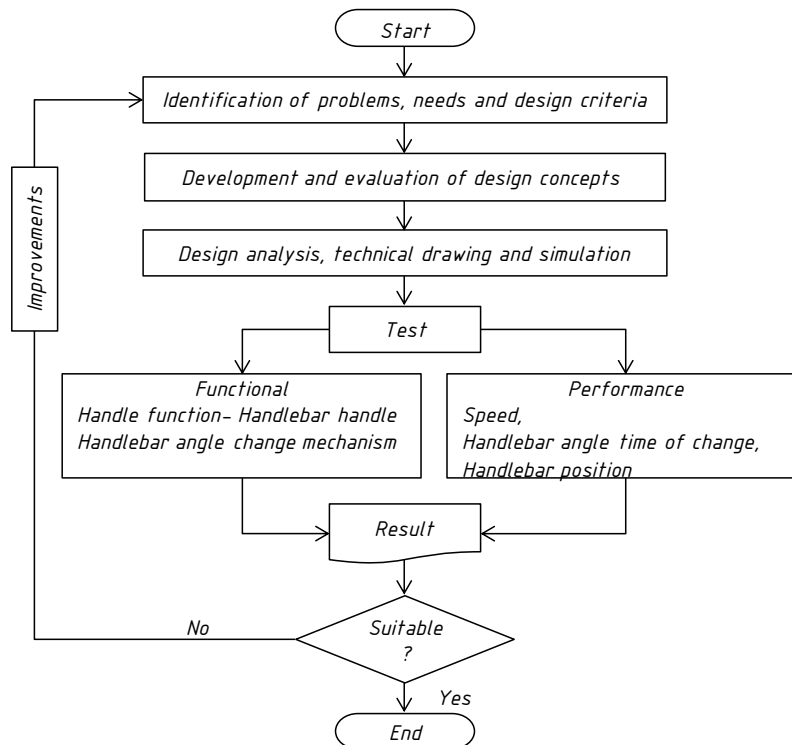

Fig. 1 - Flowchart of the design process

Measurements of body and handlebar are done on a two-wheel tractor Yanmar BRM-DX 8.5 HP. Body and handlebar sizes are used for simulation purposes using AutoCAD software. Measures on the tractor handlebar include the length of the handle, the length of the main frame of the handlebar, the width between the main frame of the handlebar, the length and width of the handlebar head. The measured tractor parts other than the handlebar include reversible iron wheel diameter, length and width of the gearbox, length and width of the engine holder. Measurement of two-wheel tractor parts in addition to steering handlebar is done only from side view position.

Two-dimensional images of the body and handlebar are made in the AutoCAD 2017 software, using the dimension of the tractor. For simulation, the steering handlebar angle is varied according to climb position requirements. The change of handlebar angle is simulated on the slope of  $40^\circ$ ,  $45^\circ$ ,  $50^\circ$ ,  $55^\circ$ , and  $60^\circ$  with a height of 150 cm. The simulation is plotted at 50 cm, 100 cm, and 150 cm altitudes with a safe distance between the front end of the engine cradle and a 10 cm slope. The simulation aims to get the value of the change in the handlebar angle on each slope that has been determined. Simulation of the difference in the angle of the two-wheel tractor can be seen in Fig. 2.

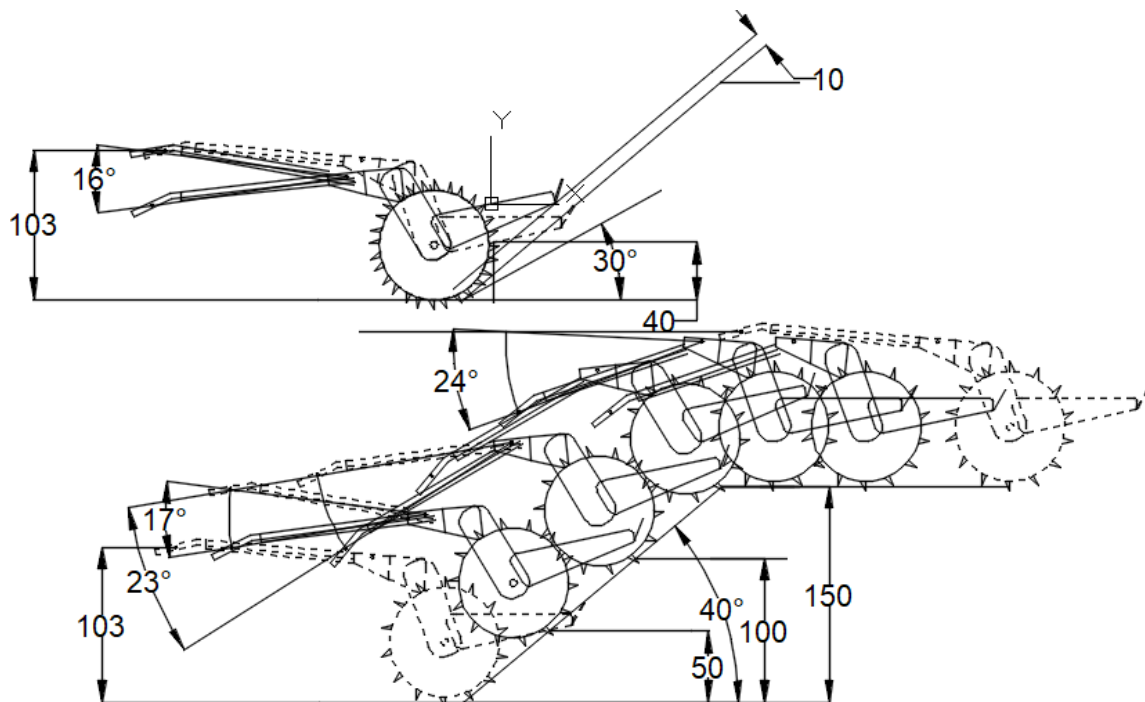

Fig. 2 - Simulation change of handlebar angle of tractor wheel

#### **Identification of problems, needs and design criteria**

The identification stage to be performed is an observation to identify the movement related to the operation of the tractor when climbing the terraced rice fields, as well as the technical problem. The dimensions and weight of the tractor must be measured as initial conditions data. The two-wheel tractor components to be measured in size and weight are the engine, engine cradle frame, gearbox, wheel and tractor handlebar. Furthermore, a simulation of the change of the handlebar angle to the sloping path is made.

#### **Development and evaluation of design concepts**

The type-I concept is a modified steering handlebar structure so that the angle of the tractor body can be adjusted and then locked with a pin so that it does not change position. The locking mechanism with the pin is done by moving the pin according to the change in the handlebar. Then, the steering handlebar is lifted in such a way that the front of the tractor is lifted and the tractor's wheels touch the sloped wall, while the handlebar position is still comfortably controlled and does not touch the ground. The angle of the lift can be changed according to operational conditions: when you want to approach the cliff while climbing and when you finish climbing. The type-II concept is a modified steering handlebar structure so that it can adjust the angle of the tractor body using the gear locking mechanism. The locking mechanism with the gear can be pulled with the pull lever. The type-I and type-II concepts can be seen in Fig. 3 and Fig. 4.

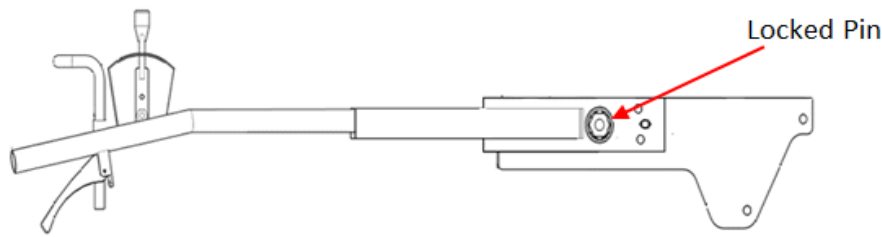

**Fig. 3 - Concept I with adjustable handlebar with pin lock**

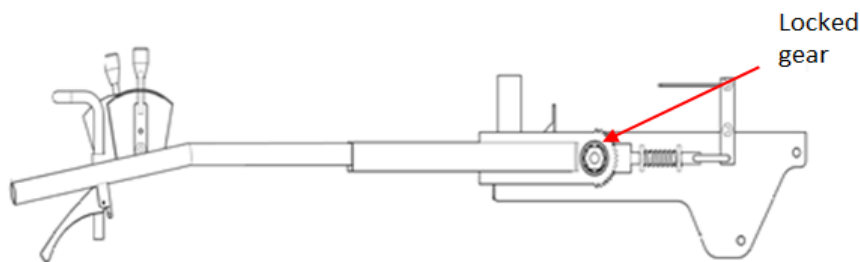

**Fig. 4 - Concept II with adjustable handlebar using gear plate**

Evaluation of design concepts aims to choose the best design concept by the required criteria. The proposed design concept needs to be evaluated using a weighting factor with the objective tree method. The use of the aim tree method is done by separating the concept of design with the need for more prioritized design criteria. All weights are summed to ensure the arithmetic validity of these weights.

The objective tree is done by evaluating the desired goals and sub-goals. Objectives and sub-goals are assessed given weighting values following the interests and needs in tool design. The primary purpose (i) in the design is to improve the performance of the two-wheel tractor up the slope by modifying the steering wheel. Based on the considerations of the main objectives, there are three sub-goals, (ii) change the handlebar angle, (ii) manufacturing and (iii) angle locking strength.

Based on the evaluation of concept selection using an objective tree method and decision making using a decision-making matrix. Based on the result of scoring comparing type-I and type-II concept, it is found that the total value of type-II concept is higher than that of the type-I concept. This shows that the type-II concept has a better advantage than type-I concept with the consideration of previous goals. The type-II concept is chosen in the design of the hinged handlebar.

### ***Design analysis and technical drawing***

The first step of the design process handlebar is the determination of the width of the handlebar head (handlebar head). It is considered the relation with the size of the gearbox width and the location of the tractor transmission lever. However, the design of the adjusted width of the handlebar without hinge is 135 mm. The second step in the process of designing the handlebar is to determine the distance between the main frame of handlebar right and left. Things to consider are the convenience when held by the operator, as well as the ease of reaching the transmission gear lever by two-wheel operators. The distance between the main frame of the right and the left handlebar is 770 mm. The main frame of the handlebar is made of pipe with 40 mm diameter and has a total length of 1220 mm.

The third step in the process of designing the handlebar is to determine the total length of the handlebar from the handlebar head end to the handlebar mainframe end. Mechanisms change the handlebar angle using a locking system between gear equipped spring. By analysing the hinge shaft size as the base of the gears on the handlebar main frame, an axis with a diameter of 19 mm is obtained. The gear in the main frame of the handlebar has 18 teeth, while on the gear plate it uses only five teeth. Locks are drawn using a lever system. The pull arm is pulled with a sling cable that connects to the operator handle. The handlebar angle can be generated by 10°, 20°, 30°, and 40°. The mechanism of changing the handlebar angle can be seen in Fig. 5.

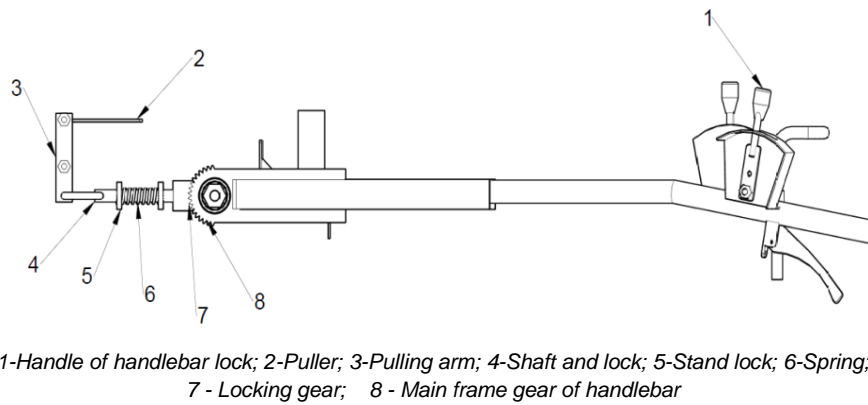

**Fig. 5 - Mechanisms change the angle of the hinged handlebar**

The novelty of the hinged steering handlebar is that the handlebar tilt angle can be adjusted easily. Therefore, it is necessary to design a locking system so that when operating a two-wheel tractor, the desired handlebar angle position can be maintained. The locking system consists of a spring, locking shaft, locking gear plate, shaft mount, lever arm, pulling sling cable and pulling handle.

#### **Performance testing of two-wheel tractors on slope trajectory**

The performance test of the two-wheel tractor on the slope trajectory was carried out using a two-wheel tractor BRM-DX Yanmar type with 8.5 HP power, 2200 rpm rotation using hinged finned wheels with a  $-15^\circ$  fin angle. The performance of the two-wheel tractor that is measured is the forward speed of the tractor. The test result data is used to compare the performance between the two-wheel tractor handlebar with hinges and without hinges. Performance testing is carried out on the slope trajectory at Siswadi Soepardjo Field Laboratory. Slope trajectory has 150 cm length and an inclination of  $45^\circ$  and  $60^\circ$ , with three replications of each slope inclination.

The change of handlebar angle to the sloping path is done before climbing the slope trajectory. The forward motion of the two-wheel tractor is documented using the camera to obtain a two-wheel tractor time up the slope trajectory, as well as to know the position of the tractor handlebar against the operator position. The distance of the truck and the time taken by the tractor are measured from the preparation stage at a length of 1.5 m from the base of the slope to the wheels of the two-wheel tractor across the top of the slope. The forward speed of the tractor is obtained by calculation using linear velocity parameters. The performance testing scheme on the sloping path can be seen in Fig. 6.

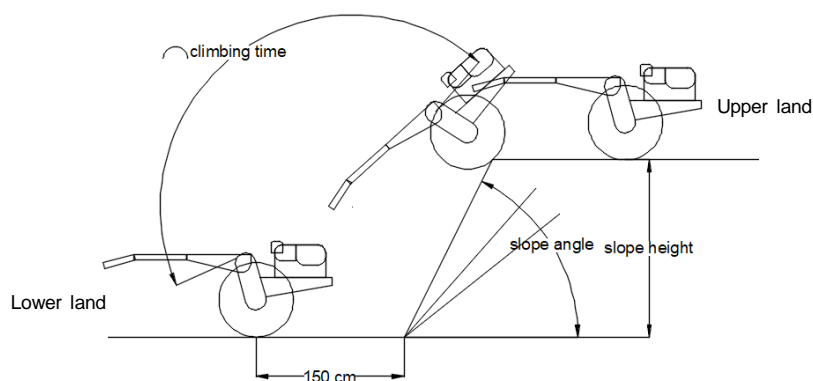

**Fig. 6 - Performance testing scheme on slope trajectory**

## **RESULTS**

#### **The results of the two-wheel tractor steering handlebar simulation in AutoCAD**

The handlebar of two-wheel tractor simulated using AutoCAD software to know the change of handlebar angle to the inclination of slope trajectory. The maximum angle that can be crossed by a tricycle wheel handlebar without a hinge is  $30^\circ$ . If the slope angle is  $90^\circ$ , the two-wheel handlebar tractor without hinge can cross the maximum slope to a height of 36 cm. The result of the simulation of the change in handlebar angle to slope gradient can be seen in Table 1.

Table 1

Simulation results change the handlebar angle to the slope

Angle slopes	Changes in the handlebar angle			
	Start (0 cm)	climbing distance (50 cm)	climbing distance (100 cm)	climbing distance (150 cm)
30°	0°	0°	0°	0°
40°	16°	-17°	-23°	24°
45°	25°	-17°	-23°	15°
50°	32°	-17°	-23°	8°
55°	40°	-15°	-20°	-5°
60°	45°	-12°	-21°	-12°

Turning to an angle that is positive can be interpreted as the handlebar of the tractor must be lifted by the value of a positive angle. Conversely, if the angle is negative, then the tractor handlebar should be lowered by a negative value of the angle. The above simulation results are used in performance testing, i.e., change in handlebar angle as it begins to climb the slope trajectory.

**Simulation result of an adjustable handlebar two-wheel tractor test**

The received stress of the main frame of the handlebar and the lock can be seen in Fig. 7 and Fig. 8. The maximum stress occurs at the exact locking portion of the connection between the locking shaft and the end of the latch gear plate. Equivalent stress occurred at  $4.38 \times 10^8$  Pa at the tip of the gear plate of the handlebar engagement latch which clashed with the main gear frame of the handlebar. Meanwhile, the equivalent stress on the shaft is  $2.83 \times 10^8$  Pa. The result is still below the tensile stress of AISI 1045 (S45C) material in AutoFEM software of  $6.25 \times 10^8$  Pa.

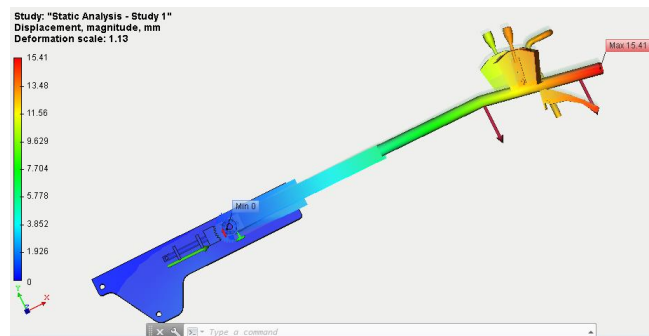

Fig. 7 - Displacement occurs in the main frame of handlebar and lock

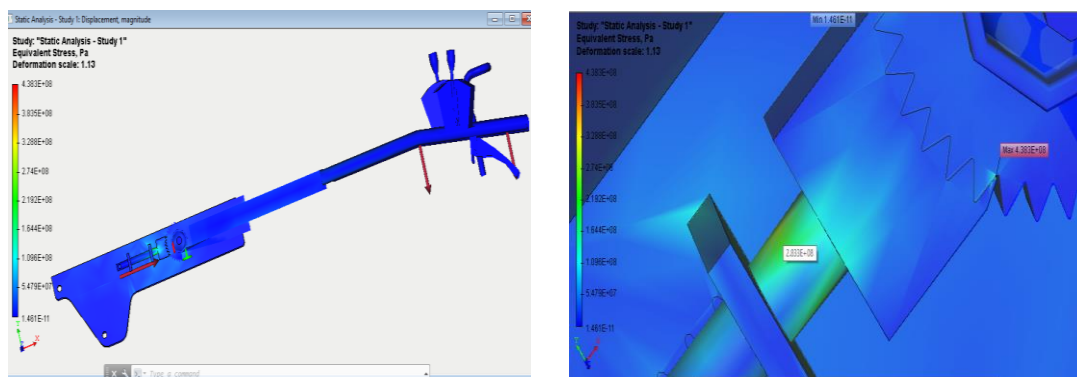
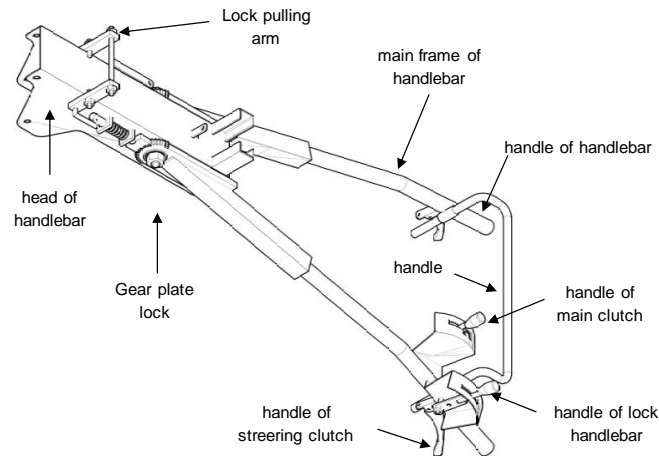

Fig. 8 - Equivalent stress received by the mainframe and lock

**Prototype and adjustable handlebar specifications**

Adjustable handlebar prototype and its components can be seen in Fig. 9. The adjustable handlebar has four tilt angle changes to the main frame of the handlebar that can be applied while climbing the terraced rice field slopes. Some adjustable handlebar positions for each of the 10°, 20°, 30°, and 40° main frame of handlebar angles can be adjusted to the slope; they are shown in Fig. 10.



**Fig. 9 - Prototype of adjustable handlebar and components**

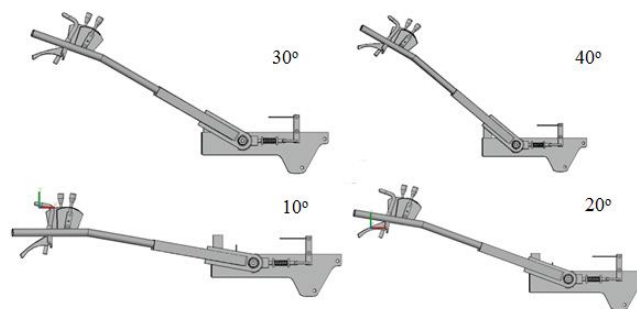

**Fig. 10 - Handlebar angle position at 10°, 20°, 30° and 40°**

### **Functional Test**

Functional testing is done by observing the function of the entire component and the handlebar section. At the time of trial, the primary clutch with a clutch cable puller works well. Steering clutch with pulling clutch cable works well against the two-wheel drive traction. The transmission lever mechanism works well against forwarding speeds of Low 1, Low 2, and backward motion.

Testing the change of handlebar angle is also done by slightly lifting the handle of hand tractor and then pulling the lever lock. The force required to pull the locking lever is below 98.1 Newton (10 kg). If the gear plate and the gears of the handlebar mainframe don't touch each other, the handlebar mainframe can be moved according to the desired angle. After that, the locking handles are released from the gear plate.

### **Soil condition trajectory of slope testing**

The slope with a testing inclination of 45° and 60° has an average water content of 47.52% and 47.49% on a dry basis with the dry bulk density of 0.988 g·cm<sup>-3</sup> and 1.008 g·cm<sup>-3</sup>. The average soil penetration resistance on the slope tracks 45° and 60° were 972.10 kPa and 944.65 kPa respectively. The result of a porosity test on 45° and 60° slope trajectory is 62.72%, 61.97%, respectively. The result of the measurement of soil physical and mechanical properties shows that each slope path has high water content. In general, the soil on the 45° and 60° slope has low dry bulk density so that the porosity of the soil is high. Slope trajectory inclination at 45° has higher soil penetration resistance, so that slope trajectory has harder soil.

The result of tractor performance in climbing the sloping land with an adjustable handlebar with two variations of the handlebar angle, i.e., 20° angle handlebar for 45° slope and 40° handlebar angle for 60° slope, shows good news. The selection of the handlebar angle to the slope is based on the simulation result of tractor handlebar using CAD software. The change in the handlebar angle to the recommended slope can be seen in Table 2. Performance tests include measurements of tractor forward speed, the time change of adjustable handlebar angle and comparison of handlebar handle position with an operator position.

### Performance Tractor with adjustable Handlebar

A tractor will lose stability and start to overturn when the normal to ground component of a wheel load becomes zero (Spencer, 1978). The result of the tractor's performance in climbing the sloping land is at a handlebar angle of 20° for a slope of 45° and a handlebar angle of 40° for a slope of 60°. The selection of a handlebar angle to the slope is based on the simulation result of tractor handlebar using CAD software. The change of handlebar angle to the recommended slope can be seen in Table 2.

**Table 2**

**Changes in handlebar angle to the slope**

Slope angle	Handlebar angle
30°	0°
40°	10°
45°	20°
50°	30°
60°	40°

The forward speed of the tractor is one of the basic parameters in knowing the performance of a two-wheeled tractor. Sakai *et al.*, (1987), stated that the tractor's forward velocity in performing farm operations ranged from 0.25 m·s<sup>-1</sup> to 1.2 m·s<sup>-1</sup>. The forward speed of the two-wheeled tractor with handlebar adjustable to the slope of 45°, 150 cm slope height, was 1.04 m·s<sup>-1</sup> with an average slip of 23.04%. The forward speed of a two-wheeled tractor with an adjustable handlebar on a slope of 60° with a height of 150 cm fails because of the slip and wheel stop. The wheels stop because the torque on the cage wheels is too slight to climb the slopes to the 60° inclination. The average maximum torque generated by a two-wheeled BRM-DX tractor is 825.20 Nm. Theoretically, when calculating the ability to climb the slope, the two-wheeled tractor can climb the slope up to 63.7°. On the wheels of a two-wheeled tractor, the wheel slip is heavily influenced by the number of fins, the fin shape, the tensile load provided and the soil conditions at which the test is performed. Failure is due to the condition of the slope soil, namely high water content and low dry bulk density, so the soil reaction to the wheel fin is not able to drive the tractor to climb the steep slope.

The performance test of a two-wheeled tractor with an adjustable handlebar was then performed on a slope smaller than 60°. After performing the experiment several times, finally, on a slope with an inclination of 57°, 120 cm height, the tractor's two wheels managed to climb. The average climbing speed of the slope conditions was 0.94 m·s<sup>-1</sup> with an average slip of 17.00%. The experiment showed that the slope corresponds to the theoretical calculation result, i.e., that the two-wheeled tractor with adjustable handlebar can climb the 57° slope. The handlebar weight influences tractor's performance in climbing the sloping land.

Meanwhile, a two-wheel tractor test using handlebar without hinge failed to climb the slope trajectory with an inclination of 45° and 60°. This failure is caused by the position of the handlebar which must be pushed down so, the front of the tractor gets out of control. However, the handlebar handle without hinges touches the ground so that it inhibits the climbing of the two-wheeled tractor (Fig. 11).



**Fig. 11 - Handle position using handlebar without hinge while climbing 45° and 60° slope**



The handle position (handlebar) is critical to the safety and comfort of the operator when operating the two-wheeled tractor, as well as the effect of the slope gradient that can be crossed by the tractor. The handle position of the two-handed wheel handlebar without a hinge while climbing the slope with an inclination of 45° and 60° requires the operator to bend. This is done to leverage the handlebar down so that the front of the tractor does not hit the slope. The force of handlebar leverage is 159.9 N (16.3 kg). Then, in a bent position, the operator must keep control of the two-wheeled tractor up the slope so that the equilibrium and mobility to move are reduced. However, unlike the two-wheeled handlebar tractor when operated the operator remains in a state of standing. According to *Tarwaka and Sudiajeng, (2004)* and *Godwin et al., (2007)*, to minimize the effect of fatigue and subjective complaints, the work must be designed so as not to reach too much, bend or move with unnatural head position. The following should be considered when testing the climbing tractor: (i) there is no place for legs and knees, (ii) must hold a heavy object ( $\geq 45$  N), (iii) often reaching up, down, and sideways, (iv) usually work is done by pressing down, (v) high mobility is required. Thus, the use of adjustable handlebar adjusted to the slope has better performance compared with the fixed handlebar. The difference of handle position to the operator on the slope of 45° and 60° is shown in Fig. 12.



Fig. 12 - Differences in the handle position of adjustable handlebar and fixed handlebar

## CONCLUSIONS

The dimensions of adjustable handlebar design are: the total length of 1700 mm, the width of 135 mm, a distance of the mainframe of 770 mm, some adjustable angles (10°, 20°, 30°, 40°), and a clutch cable is used. Finite Element Analysis shows that the handlebar locking construction is strong enough. Functional testing results show that the handlebar locking mechanism, handle of steering clutch, grip of the main grip, transmission handle, handle of acceleration, and handle of lock handlebar can function well. The gears and main gears are tightly fitted and can be used as a handlebar for climbing terraces.

The performance test results show that the hinged handlebar can climb the 45° slope, with 150 cm height and the 57° slope trajectory, with 120 cm height, while the handlebar without hinge fails to climb. Two-wheeled hinged handlebar tractor climbed 45° and 57° slopes with an average forward speed of 1.04 m·s<sup>-1</sup> and 0.94 m·s<sup>-1</sup>. When starting up the slope, the position of the operator can remain to standing (not necessarily bending) when operating a two-wheeled tractor with a hinged handlebar. Tractor with hinged handlebar, with handlebar angle (10°, 20°, 30°, and 40°) adjusted to slope maximum of 57° has better performance compared to the handlebar without a hinge.

## REFERENCES

- [1] Cebro I, W Hermawan, (2006), Computer-aided design system for two-wheeled cage tractors, *Jurnal Keteknik Pertanian*, Vol.20(2), pp.1-10;
- [2] Cebro IS, A Sitorus, (2019), Performance Evaluation of a Hand Tractor to Climbing Sloping Land, *International Journal Of Scientific & Technology Research*, Vol.8(7), pp.1-5;
- [3] Edlund J., Keramati E., Servin M., (2013), A long-tracked bogie design for forestry machines on soft and rough terrain, *Journal of Terramechanics*, Vol.50(2), pp.73-83;
- [4] Fabbri A, C Cevoli, G Cantalupo, (2017), A method for handlebars ballast calculation in order to reduce vibrations transmissibility in walk behind tractors, *Journal of Agricultural Engineering*, Vol.48(2), pp.81-87;
- [5] Godwin A, T Eger, A Salmoni, S Grenier, P Dunn, (2007), Postural implications of obtaining line-of-sight for seated operators of underground mining load-haul-dump vehicles, *Ergonomics*, Vol.50(2), pp.192-207;
- [6] Hunter A, (1993), A review of research into machine stability on slopes, *Safety science*, Vol.16(3-4), pp.325-339;
- [7] Kumar R, H Raheman, (2015), Design and development of a variable hitching system for improving stability of tractor trailer combination, *Engineering in agriculture, environment and food*, Vol.8(3), pp.187-194;
- [8] Mocanu V, I Hermenean, (2010), Experimental researches concerning dynamics and energetic of two-wheel tractor-semitrailer systems, *INMATEH-Agricultural Engineering*, Vol.32(3), pp.59-64;
- [9] Ni J, W Wang, J Hu, C Xiang, (2019), Relaxed static stability for four-wheel independently actuated ground vehicle, *Mechanical Systems and Signal Processing*, Vol.127, pp.35-49;
- [10] Potau X, M Comellas, M Nogués, J Roca, (2011), Comparison of different bogie configurations for a vehicle operating in rough terrain, *Journal of Terramechanics*, Vol.48(1), pp.75-84;
- [11] Sakai J, T Kishimoto, S Phongsupasamit, (1987), A study on engineering design theories of iron wheels for plowing, *Agricultural Mechanization in Asia, Africa and Latin America*, Vol.18(4), pp.11-18;
- [12] Shi T, (2015), Development and test of automatic corn seedling transplanter, *Transactions of the Chinese Society of Agricultural Engineering*, Vol.31(3), pp.23-30;
- [13] Sitorus A, W Hermawan, RPA Setiawan, (2017), Design and performance of combine corn transplanter powered by hand tractor, *2017 International Conference on Computing, Engineering, and Design (ICCED)*, 1-5;
- [14] Spencer H, (1978), Stability and control of two-wheel drive tractors and machinery on sloping ground, *Journal of agricultural engineering research*, Vol.23(2), pp.169-188;
- [15] Tarwaka S, Sudiajeng L, (2004), *Ergonomics for safety, occupational health and productivity*, UNIBA Press, Surakarta, Indonesia.